

ONKYO SERVICE MANUAL

AUDIO VIDEO CONTROL RECEIVER MODEL TX-DS696

AUDIO VIDEO CONTROL RECEIVER MODEL TX-DS595

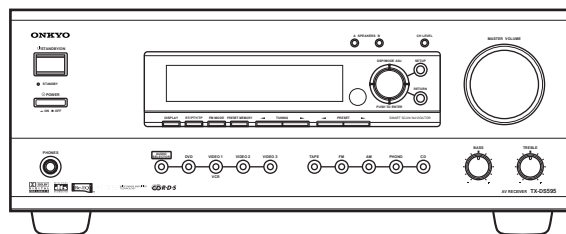
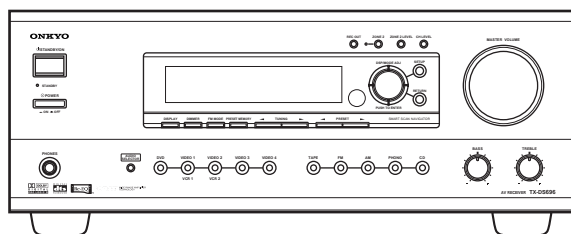

Black, Golden and Silver models

BMDD	120V AC, 60Hz
BMPP,SMPP BMPA,GMPA	230-240V AC, 50Hz
BMWT,GMWT GMWR	220-230V/120V AC, 50/60 Hz

Black, Golden and Silver models

BMDD	120V AC, 60Hz
BMPP,SMPP BMPA,GMPA	230-240V AC, 50Hz
BMWT,GMWT GMWR	220-230V/120V AC, 50/60 Hz
GMGT	220-230V AC,50 Hz

SAFETY-RELATED COMPONENT WARNING!!
COMPONENTS IDENTIFIED BY MARK  ON THE SCHEMATIC DIAGRAM AND IN THE PARTS LIST ARE CRITICAL FOR RISK OF FIRE AND ELECTRIC SHOCK. REPLACE THESE COMPONENTS WITH ONKYO PARTS WHOSE PART NUMBER APPEAR AS SHOWN IN THIS MANUAL.

MAKE LEAKAGE CURRENT OR RESISTANCE MEASUREMENTS TO DETERMINE THAT EXPOSED PARTS ARE ACCEPTABLY INSULATED FROM THE SUPPLY CIRCUIT BEFORE RETURNING THE APPLIANCE TO THE CUSTOMER.

TABLE OF CONTENTS

Specifications TX-DS595	2
Specifications TX-DS696	3
Service procedures	4
Panel views TX-DS595	5
Panel views TX-DS696	8
IC block diagrams and descriptions	11
Microprocessor TX-DS595	20
Main microprocessor	20
Sub microprocessor	22
Microprocessor TX-DS696	24
Main microprocessor	24
Sub microprocessor	26
About debug mode	27
FL tube view	28
Printed circuit board-parts list TX-DS595	29
Printed circuit board-parts list TX-DS696	34
Wiring view TX-DS595	39
Block diagram TX-DS595	41
Wiring view TX-DS696	43
Block diagram TX-DS696	45
Schematic diagrams & PC board views	47
Input section TX-DS595	47
Input section TX-DS696	51
Power amplifier section 1	55
Power amplifier section 2	59
Display section TX-DS595	63
Display section TX-DS696	67
Video section TX-DS595	71
Video section TX-DS696	75
DSP section	81
Adjustments and confirmation procedures	87
Exploded view & Parts list TX-DS595	89
Exploded view & Parts list TX-DS696	93
Packing view TX-DS595	97
Packing view TX-DS696	98

SPECIFICATIONS

AMPLIFIER SECTION

Continuous Average Power output (FTC)

All channels: 75 W per channel min. RMS at 8 ohm , 2 channels driven from 20Hz to 20 kHz with no more than 0.08% total harmonic distortion. 100 W min. RMS at 6 ohm, 2 channels driven from 1 kHz with no more than 0.1% total harmonic distortion.

Continuous Power output (DIN)	110 W at 6 ohm
Maximum Power output (EIAJ)	140 W at 6 ohm
Dynamic Power Output (Stereo)	2 × 210 W at 3 ohm 2 × 155 W at 4 ohm 2 × 90 W at 8 ohm
Total Harmonic Distortion:	0.08% at rated power 0.08% at 1 W output
IM Distortion:	0.08% at rated power 0.08% at 1 W output
Damping Factor:	60 at 8 ohm
Input Sensitivity and Impedance	
PHONO:	2.5 mV, 50 kohm
LINE (CD, TAPE, DVD, VIDEO 1,2,3):	200 mV, 50 kohm
MULTICHANNEL INPUT (FRONT L/C/R, SURROUND L/R):	200 mV, 50 kohm
(SUBWOOFER):	36 mV, 50 kohm
COAXIAL 1, 2 (DIGITAL):	0.5 Vp-p, 75ohm
DVD, VIDEO1,2,3:	1 Vp-p, 75ohm 1 Vp-p, 75ohm (Y) 0.28 Vp-p, 75ohm (C)

Output Level and Impedance

Rec out (TAPE, VIDEO 1):	200 mV, 2.2 kohm
Pre out:	1 V, 470 ohm
VIDEO (VIDEO 1, MONITOR OUT):	1 Vp-p, 75 ohm 1 Vp-p, 75 ohm (Y) 0.28 Vp-p, 75 ohm (C)

Phono Overload:	180 mV RMS at 1 kHz, 0.5% T.H.D.
Frequency Response:	10 Hz to 100 kHz: +1 dB, -3 dB
RIAA Deviation:	20 Hz to 20 kHz : ±0.8 dB
Tone Control	
Bass:	±10 dB at 50 Hz
Treble:	±10 dB at 20 kHz
Signal-to-Noise Ratio (Stereo)	
Phono:	80 dB (IHF A, 5 mV input)
CD/Tape:	100 dB (IHF A, 0.5 V input)
Muting:	- 50 dB

TUNER SECTION

FM

Tuning Range:	87.5 to 108.0 MHz (50-kHz steps)
Usable Sensitivity	
Mono:	11.2 dBf, 1.0 μV (75 ohm IHF) 0.9 μV (75 ohm DIN)
Stereo:	17.2 dBf, 2.0 μV (75 ohm IHF) 23 μV (75 ohm DIN)
50 dB Quieting Sensitivity	
Mono:	17.2 dBf, 2.0 μV (75 ohm)
Stereo:	37.2 dBf, 20 μV (75 ohm)
Capture Ratio:	2.0 dB
Image Rejection Ratio:	
USA & Canadian models:	40 dB
Other area models:	85 dB
IF Rejection Ratio:	90 dB
Signal-to-Noise Ratio	
Mono:	76 dB
Stereo:	70 dB
Alternate Channel Attenuation:	55 dB
Selectivity:	50 dB (DIN)
AM Suppression Ratio:	50 dB
Total Harmonic Distortion	
Mono:	0.2%
Stereo:	0.3%
Frequency Response:	30 Hz to 15 kHz, ±1.0 dB
Stereo Separation:	45 dB at 1 kHz 30 dB at 100 Hz to 10 kHz

AM

Tuning Range	
USA & Canadian models:	530 to 1,710 kHz (10-kHz steps)
European & Australian models	522 to 1,611 kHz (9-kHz steps)
Worldwide models:	531 to 1,602 kHz (9-kHz steps) 530 to 1,710 kHz (10-kHz steps)
Usable Sensitivity:	30 μV
Image Rejection Ratio:	40 dB
IF Rejection Ratio:	40 dB
Signal-to-Noise Ratio:	40 dB
Total Harmonic Distortion:	0.7%

GENERAL

Power Supply:	AC 120 V, 60 Hz (USA & Canadian models) AC 230-240 V, 50 Hz (European & Australian models) AC 220-230 and 120 V switchable, 50/60 Hz (Worldwide models)
Power Consumption:	4.7 A 380 W
Dimensions (W × H × D):	435 × 175 × 431 mm 17-1/8" × 6-7/8" × 16-15/16"
Weight:	25.4 lbs. (USA & Canadian models) 12.5 kg (Other models)

REMOTE CONTROLLER

Transmitter:	Infrared
Signal range:	Approx. 5 meters, 16 ft.
Power supply:	Two "AA" batteries (1.5 V × 2)

Specifications and features are subject to change without notice.
Power supply and voltage vary depending on the area in which the unit is purchased.

SPECIFICATIONS

AMPLIFIER SECTION

Continuous Average Power output (FTC)

All channels: 100 W per channel min. RMS at 8 ohm , 2 channels driven from 20Hz to 20 kHz with no more than 0.08% total harmonic distortion. 125 W min. RMS at 6 ohm, 2 channels driven from 1 kHz with no more than 0.1% total harmonic distortion.

Continuous Power output (DIN)	130 W at 6 ohm
Maximum Power output (EIAJ)	160 W at 6 ohm
Dynamic Power Output (Stereo)	2 × 230 W at 3 ohm 2 × 170 W at 4 ohm 2 × 115 W at 8 ohm
Total Harmonic Distortion:	0.08% at rated power 0.08% at 1 W output
IM Distortion:	0.08% at rated power 0.08% at 1 W output
Damping Factor:	60 at 8 ohm
Input Sensitivity and Impedance	
PHONO:	2.5 mV, 50 kohm
LINE (CD, TAPE, DVD, VIDEO 1-4):	200 mV, 50 kohm
MULTICHANNEL INPUT (FRONT L/C/R, SURROUND L/R):	200 mV, 50 kohm
(SUBWOOFER):	36 mV, 50 kohm
COAXIAL 1, 2 (DIGITAL):	0.5 Vp-p, 75ohm
DVD, VIDEO1-4:	1 Vp-p, 75ohm 1 Vp-p, 75ohm (Y) 0.28 Vp-p, 75ohm (C)
COMPONENT VIDEO 1, 2:	1 Vp-p, 75ohm(Y) 0.7 Vp-p, 75ohm(Cb /CR, Pb /PR)
Output Level and Impedance	
Rec out (TAPE, VIDEO 1, 2):	200 mV, 2.2 kohm
Pre out:	1 V, 470 ohm
VIDEO (VIDEO 1, 2, MONITOR OUT):	1 Vp-p, 75 ohm 1 Vp-p, 75 ohm (Y) 0.28 Vp-p, 75 ohm (C)
COMPONENT VIDEO OUT:	1 Vp-p, 75 ohm (Y) 0.7 Vp-p, 75 ohm (Cb/CR, Pb/PR)
Phono Overload:	110 mV RMS at 1 kHz, 0.5% T.H.D.
Frequency Response:	5 Hz to 100 kHz: +1 dB, -3 dB
RIAA Deviation:	20 Hz to 20 kHz : ±0.8 dB
Tone Control	
Bass:	±10 dB at 50 Hz
Treble:	±10 dB at 20 kHz
Signal-to-Noise Ratio (Stereo)	
Phono:	80 dB (IHF A, 5 mV input)
CD/Tape:	100 dB (IHF A, 0.5 V input)
Muting:	- 50 dB

TUNER SECTION

FM

Tuning Range:	87.5 to 108.0 MHz (50-kHz steps)
Usable Sensitivity	
Mono:	11.2 dBf, 1.0 μV (75 ohm IHF) 0.9 μV (75 ohm DIN)
Stereo:	17.2 dBf, 2.0 μV (75 ohm IHF) 23 μV (75 ohm DIN)
50 dB Quieting Sensitivity	
Mono:	17.2 dBf, 2.0 μV (75 ohm)
Stereo:	37.2 dBf, 20 μV (75 ohm)
Capture Ratio:	2.0 dB
Image Rejection Ratio:	
USA & Canadian models:	40 dB
Other area models:	85 dB
IF Rejection Ratio:	90 dB
Signal-to-Noise Ratio	
Mono:	76 dB
Stereo:	70 dB
Alternate Channel Attenuation:	55 dB
Selectivity:	50 dB (DIN)
AM Suppression Ratio:	50 dB
Total Harmonic Distortion	
Mono:	0.2%
Stereo:	0.3%
Frequency Response:	30 Hz to 15 kHz, ±1.0 dB
Stereo Separation:	45 dB at 1 kHz 30 dB at 100 Hz to 10 kHz

AM

Tuning Range	
USA & Canadian models:	530 to 1,710 kHz (10-kHz steps)
European & Australian models	522 to 1,611 kHz (9-kHz steps)
Worldwide models:	531 to 1,602 kHz (9-kHz steps) 530 to 1,710 kHz (10-kHz steps)
Usable Sensitivity:	30 μV
Image Rejection Ratio:	40 dB
IF Rejection Ratio:	40 dB
Signal-to-Noise Ratio:	40 dB
Total Harmonic Distortion:	0.7%

GENERAL

Power Supply:	AC 120 V, 60 Hz (USA & Canadian models) AC 230-240 V, 50 Hz (European & Australian models) AC 220-230 and 120 V switchable, 50/60 Hz (Worldwide models)
Power Consumption:	5.7 A 460 W
Dimensions (W × H × D):	435 × 175 × 431 mm 17-1/8" × 6-7/8" × 16-15/16"
Weight:	27.8 lbs. (USA & Canadian models) 13.5 kg (Other models)

REMOTE CONTROLLER

Transmitter:	Infrared
Signal range:	Approx. 5 meters, 16 ft.
Power supply:	Two "AA" batteries (1.5 V × 2)

Specifications and features are subject to change without notice.

Power supply and voltage vary depending on the area in which the unit is purchased.

SERVICE PROCEDURES

1. Replacing the fuses

 This symbol located near the fuses indicates that the fuse used is fast operating type. For continued protection against fire hazard, replace with same type fuse. For fuse rating refer to the marking adjacent to the symbol.

 Ce symbole indique que le fusible utilise est a rapide. Pour une protection permanente, n'utiliser que fusibles de meme type. Ce dernier est la qu le present symbol est appse.

TX-DS696

CIRCUIT NO.	PART NO.	DESCRIPTION
F901	252198	8A-UL,Fuse <D/WT/WR>
F902	252077	4A-SE-EAK,Fuse <P/WT/WR/A>
F903	252075	2.5A-SE-EAK,Fuse <P/A>
F9501	252160	2.5A-UL/T-237,Fuse <D>
	252075	2.5A-SE-EAK,Fuse <P/A/WR/WT>

TX-DS595

CIRCUIT NO.	PART NO.	DESCRIPTION
F901	252166	6.3A-UL/T237,Fuse <D/WT/WR>
F902	252076	3.15A-SE-EAK,Fuse <P/WT/WR/A/GT>
F903	252075	2.5A-SE-EAK,Fuse <P/A>
F9501	252160	2.5A-UL/T-237,Fuse <D>
	252075	2.5A-SE-EAK,Fuse <P/A/WR/WT/GT>

Note: <D>:120V model only
 <P>: European model only
 <WT>: Worldwide model only
 <WR>: Asian model only for 230V
 <GT>: 220-230V model only
 <A>: Australian model only

2. To initialize the unit

This device employs a microprocessor to perform various functions and operations. If interference generated by an external power supply, radio wave, or other electrical source results in accident which causes the specified operations and functions to operate abnormally.

To perform a result, please follow the procedure below.

1. Turn POWER to on.
2. Press and hold down the PRESET MEMORY button, then press the STANDBY button.

After "clear" is displayed, the preset memory and each mode stored in the memory, such as surround, are initialized and will return to the factory setting.

3. Disconnect Power supply cord.

3. Safety-check out

(Only U.S.A. model)

After correcting the original service problem, perform the following safety check before releasing the set to the customer. Connect the insulating-resistance tester between the plug of power supply cord and screw on the back panel.

Specifications: 3.3Mohm+/-10% at 500V.

4. Memory Preservation

This unit does not require memory preservation batteries. A built-in memory power back-up system preserves the contents of the memory during power failures and even when the unit is unplugged. The unit must be plugged in order to charge the back-up system.

The memory preservation period after the unit has been unplugged varies depending on climate and placement of the unit. On the average, memory contents are protected over a period of a few weeks after the last time the unit has been unplugged. This period is shorter when the unit is exposed to a highly humid climate.

5. Setting the AM tuning step frequency

(Worldwide models only)

The initializing setting is 9 kHz, and this needs only to be changed if you are using the unit in a 10-kHz region.

1. Press the SETUP button.
Turn the jog dial or press the ▲ and ▼ cursor buttons on the remote controller to display "3. PREFERENCE."
2. Press the jog dial or ENTER button on the remote controller.
Turn the jog dial or press the ▼ cursor buttons on the remote controller to display "AM FREQ STEP?".
3. Press the jog dial or ENTER button on the remote controller.
The currently set frequency step appears.
4. Turn the jog dial or press the ◀ and ▶ cursor buttons on the remote controller to set the frequency.
5. Press the RETURN button.
"AM FREQ STEP?" appears in the FL tube.
To exit the setup mode immediately, press the SETUP button.

6. Setting the Voltage selector (Worldwide models only)

Worldwide models are equipped with a voltage selector to conform with local power supplies. Be sure to set this switch to match the voltage of the power supply in your area before plugging in the unit.

1. Determine the proper voltage for your area: 220-230 V or 120 V.
2. If the preset voltage is not correct for your area, insert a screwdriver into the groove in the switch. Slide the switch all the way to the right (120 V) or to the left (220-230 V), whichever is appropriate.

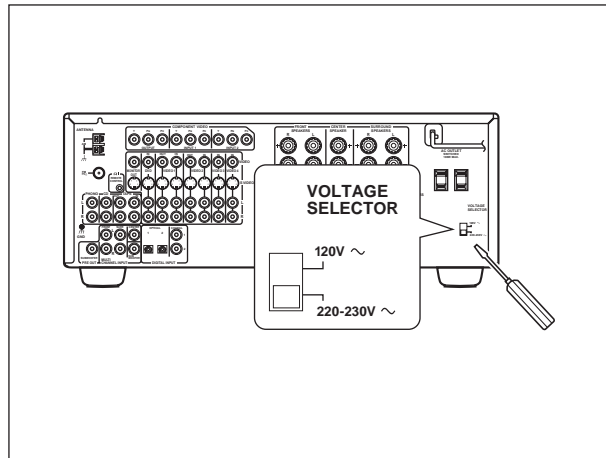

7. Changing the AM band step

With the exception of the worldwide models, a tuning step setup mode is not provided. When you change the band step, change the parts as shown below.

	To 10kHz	To 9kHz
R7780,R7781	330 ohm	Open
R7880,R7881	Open	2.2 kohm

PANEL VIEWS

Front panel

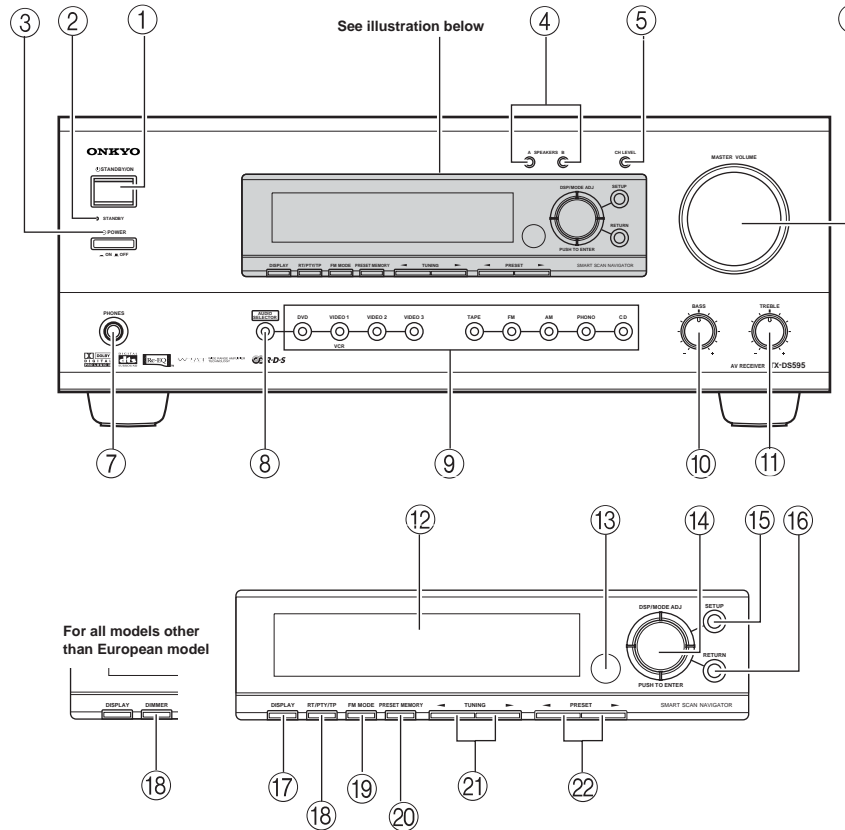

Front panel display

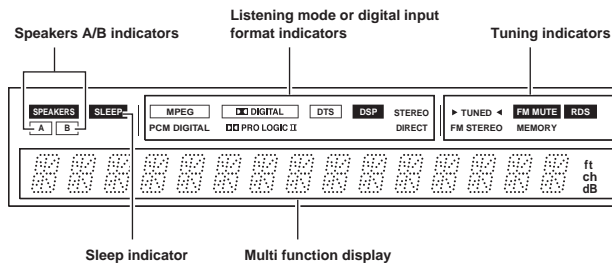

1 POWER switch

Turns on and off the main power supply for the TX-DS595.

2 STANDBY indicator

Lights when the TX-DS595 is in the standby state and flashes when a signal is received from the remote controller.

3 STANDBY/ON button

Press to turn on the TX-DS595 when in the standby state. Press again to return the TX-DS595 to the standby state.

4 SPEAKERS A/B buttons

Press these buttons to turn on and off speakers systems A and B.

5 CH LEVEL button

Press to select the channel whose level is to be adjusted.

6 MASTER VOLUME dial

The MASTER VOLUME dial is used to control the volume.

7 PHONES jack

To listen with headphones, plug a pair of headphones with a standard stereo plug into the PHONES jack on the TX-DS595 front panel. When you connect headphones, the unit will enter STEREO mode automatically and no sound will be heard from the speakers. If you have selected MULTI CH INPUT, you will hear sound only from the FRONT L and R channels. Note that the volume level for the headphones is adjustable.



8 AUDIO SELECTOR button

This button is used to select the type of audio input signal. Each time pressed, the setting cycles from "AUTO" "MULTICH" "ANALOG" and back.

9 Input source buttons (DVD, VIDEO 1-3, TAPE, FM, AM, PHONO, and CD)

These buttons are used to select the input source.

10 BASS dial

Boosts or cuts the bass response. Bass adjustment is effective only for the front speakers and headphones.

11 TREBLE dial

Boosts or cuts the treble response. Treble adjustment is effective only for the front speakers and headphones.

12 Front display

13 Remote control sensor

14 SMART SCAN NAVIGATOR jog dial and indicators

Used to make settings in the setup display, change listening mode settings, and more.

15 SETUP button

Press to enter and exit the setup mode.

16 RETURN button

Press to move up one level in the setup mode.

17 DISPLAY button

The DISPLAY button is used to display information about the current input source signal. Each time you press the display button, the screen changes to show you different information concerning the input signal.

18 RT/PTY/TP (European models only) button

This button is only available on European models. Use this button to help tune into the Radio Data System (RDS) for FM broadcasting. RDS was developed within the European Broadcasting Union (EBU) and is available in most European countries. Each time the button is pressed, the display changes from RT (radio text) to PTY (program type) to TP (traffic program) and then back to RT again.

18 DIMMER (other than European models) button

Press to set the brightness of the front display. There are 3 settings available: normal, dark, and very dark.

19 FM MODE button

When there is too much noise in the stereo reception of an FM broadcast, press to turn off the FM MUTE function.

20 PRESET MEMORY button

This button is used to assign the radio station that is currently tuned in to a preset channel or delete a previously preset station.

21 TUNING ◀/▶ buttons

Use these buttons to change the tuner frequency. The tuner frequency is displayed in the front display and it can be changed in 50 kHz increments for FM and 10 kHz (or 9 kHz) increments for AM.

When FM is selected, you can hold down one of the tuning buttons and then release it to activate the auto-search feature. It will search for a station in the direction of the button you pressed and stop when it tunes into one.

22 PRESET ◀/▶ buttons

When AM or FM is selected as the input source, press one of these buttons to jump to a radio station that you preset using the PRESET MEMORY button. Pressing the right button moves from the most recently preset station to older ones, and pressing the left button moves in the reverse order.

REMOTE CONTROLLER

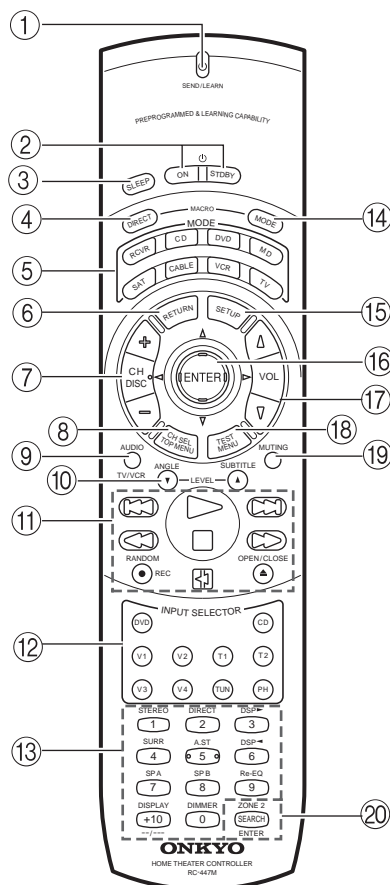

① SEND/LEARN indicator

This indicator acts as a guide when commands are programmed into or sent by the remote controller. It also warns the user when an error is made or battery power is low.

② ON/STDBY button

ON: Turns on the TX-DS595.

STDBY: Places the TX-DS595 in the standby state. Be aware that pressing the STDBY button only places the TX-DS595 in standby and does not turn the power completely off.

③ SLEEP button

Sets the sleep function.

The SLEEP button enables you to set the TX-DS595 to turn off automatically after a specified time period.

④ DIRECT MACRO button

For executing and programming the Direct Macro function.

⑤ MODE buttons and indicators

For selecting the component to be operated by the remote controller. When a MODE button is pressed, it will light green for 8 seconds. The selected MODE button will also light whenever any other operation button is pressed to tell you which mode the remote controller is in.

⑥ RETURN button

Press to move up one level in the setup mode.

⑦ CH/DISC +/- button

When in the RCVR mode, for selecting a tuner preset channel.

For selecting the disc to be played back for components with disc changers when in the DVD or CD modes.

⑧ CH SEL/TOP MENU button

CH SEL: For selecting the speaker for level adjustment when in the RCVR mode. Used together with the LEVEL ▲/▼ buttons.

TOP MENU: When in the DVD mode, for displaying the menu screen(s) recorded on DVD media.

⑨ AUDIO/TV/VCR button

AUDIO: For selecting the audio input signal. The setting changes from "AUTO" to "MULTICH" to "ANALOG" and back each time this button is pressed.

TV/VCR: Must be preprogrammed for use in the TV and VCR modes.

⑩ LEVEL ▼/ANGLE and LEVEL ▲/SUBTITLE buttons

LEVEL ▼/▲: Select the speaker whose volume is to be adjusted using the CH SEL button and adjust the volume using the LEVEL ▲/▼ buttons in the RCVR mode.

ANGLE: When in the DVD mode, for selecting a camera angle when a DVD-Video is recorded with multiple angle playback.

SUBTITLE: When in the DVD mode, for selecting one of the subtitle languages recorded on a DVD-Video.

⑪ CD/TAPE/DVD/MD operation buttons

For operating Onkyo components connected to the TX-DS595.

⑫ INPUT SELECTOR buttons

Selects an input source.

Same as the input selector buttons on front panel of the TX-DS595. The input source for each buttons is given here. DVD: DVD, CD: CD, V1: VIDEO1, V2: VIDEO2, V3: VIDEO3, V4: Not used with the TX-DS595, T1: TAPE, T2: Not used with the TX-DS595, TUN: FM/AM, PH: PHONO.

⑬ Numeric key/Listening mode selector/SP A, B/ Re-EQ/DISPLAY/DIMMER buttons

1 to 9, +10, --/--, 0: For entering the number of a track.

STEREO, DIRECT, DSP ◀▶, SURR, A.ST: You can select a listening mode.

STEREO: Changes the listening mode directly to the Stereo listening mode. If pressed, the listening mode for the selected input source set in the Listening Mode Preset is also changed to the Stereo listening mode.

SURR (Surround): Changes the listening mode to the surround mode for the current input signal (e.g., Dolby Pro Logic II, Dolby Digital, or DTS). If pressed, the listening mode for the selected input source set in the Listening Mode Preset is also changed to the Surround listening mode.

For Dolby Pro Logic II, this button also changes the mode between Dolby Pro Logic II Movie and Dolby Pro Logic II Music.

DIRECT: Changes the listening mode directly to the Direct listening mode. If pressed, the listening mode for the selected input source set in the Listening Mode Preset is also changed to the Direct listening mode.

A.ST (All Channel Stereo): Changes the listening mode directly to the Stereo listening mode. If pressed, the listening mode for the selected input source set in the Listening Mode Preset is also changed to the All Channel Stereo listening mode.

DSP ◀▶: Changes the listening mode as shown below. Direct Stereo Surround Orchestra Unplugged Studio-Mix TV Logic All Ch Stereo Direct. If pressed, the listening mode for the selected input source set in the Listening Mode Preset is also changed.

Re-EQ: Depending on the listening mode, you can turn the cinema re-equalization function on or off.

Re-EQ (re-equalization) takes the edginess or "brightness" out of your home cinema sound to compensate for the fact that sound mixed for theaters may sound too bright when played back through speakers in the home environment.

On: Select to turn on the re-equalization filter.

Off: Select to turn off the re-equalization filter.

Note:

The Re-EQ function is effective on the Dolby Pro Logic II Movie and Dolby Digital modes.

SP A, SP B: For turning on and off speakers systems A and B.

DISPLAY: For changing the display in the front display.

DIMMER: Adjusts the display brightness.

There are three settings available: normal, dark and very dark.

⑭ MODE MACRO button

For executing and programming the Macro function.

⑮ SETUP button

Press to enter and exit the setup mode.

⑯ ENTER/cursor button

For selecting and entering settings in the setup mode.

⑰ VOL ▲/▼ button

For adjusting the volume.

⑱ TEST/MENU button

TEST: Outputs a test tone for setting speaker levels. Use this button in conjunction with the LEVEL ▲/▼ and CH SEL buttons to calibrate the speakers levels.

1. Press the TEST button.

A test sound (pink noise) will be heard from the left front speaker. At this point, it is not necessary to adjust the volume of the test sound.

2. Press the CH SEL button.

The test sound will now be heard from a different speaker.

3. Use the LEVEL ▲/▼ buttons to adjust the volume of the test sound from this speaker to the same level that you heard from the previous speaker.

4. Repeat the procedure in step 2 and 3 until the volume of the test sound from all speakers is the same level.

Each time you press the CH SEL button, the test sound will be heard from a different speaker. The speaker order for calibration is front left center front right surround right surround left subwoofer.

5. Press the TEST button to exit the setting.

MENU: When in the DVD mode, this button displays the DVD menu.

⑲ MUTING button

Activates the mute function.

⑳ ZONE 2/SEARCH/ENTER button

ZONE 2: Not used with the TX-DS595.

SEARCH: When in the DVD mode, for finding the specific section on a disc where you want to start playback.

ENTER: When in the MD mode, for confirming the selection.

CONNECTION

➤ : Signal flow

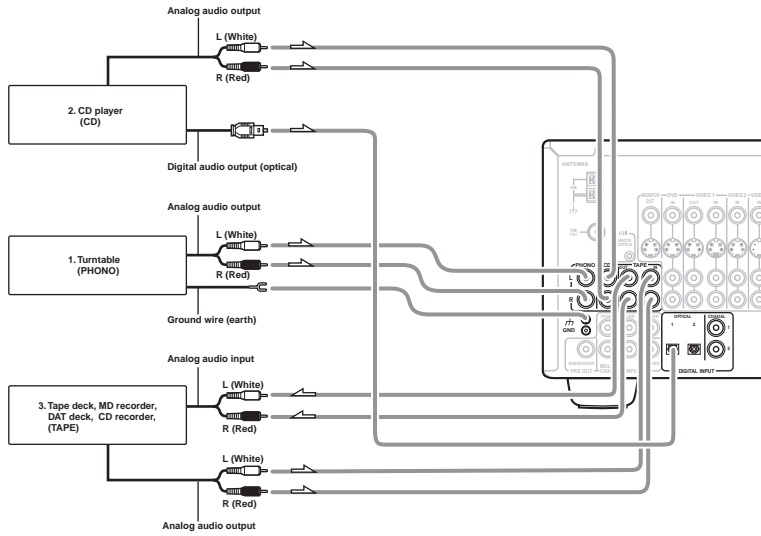

Connecting antennas

Connecting your video components

Connect to devices with terminals

Connecting speakers

Cautions regarding the AC OUTLETS connectors

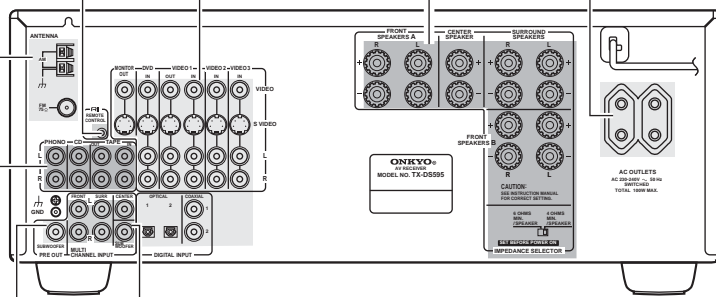

Connecting a subwoofer

Connect to devices with multichannel output

Connecting your audio components

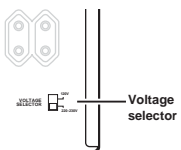

For worldwide models only

Default setting

Input source	Digital input	Multichannel
DVD	COAX 1	Yes
VIDEO 1	COAX 2	No
VIDEO 2	----	No
VIDEO 3	OPT 2	No
VIDEO 4	----	No
TAPE	----	No
FM	-----	-----
AM	-----	-----
PHONO	----	No
CD	OPT 1	No

COAX: Coaxial OPT: Optical ----: No setting []: Not applicable

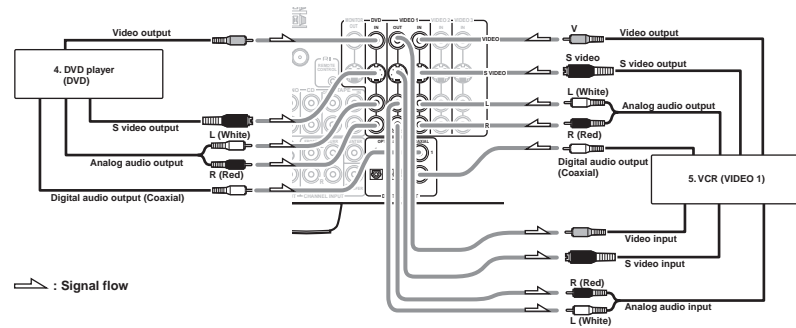

➤ : Signal flow

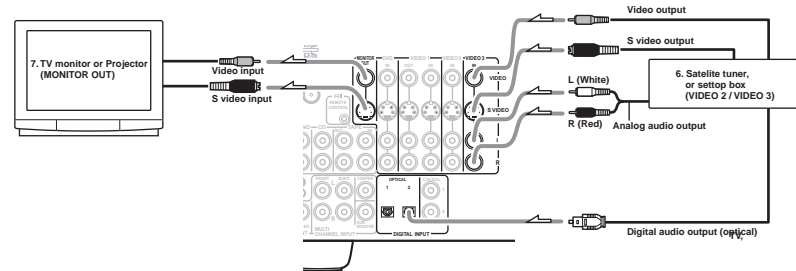

PANEL VIEWS

Front panel

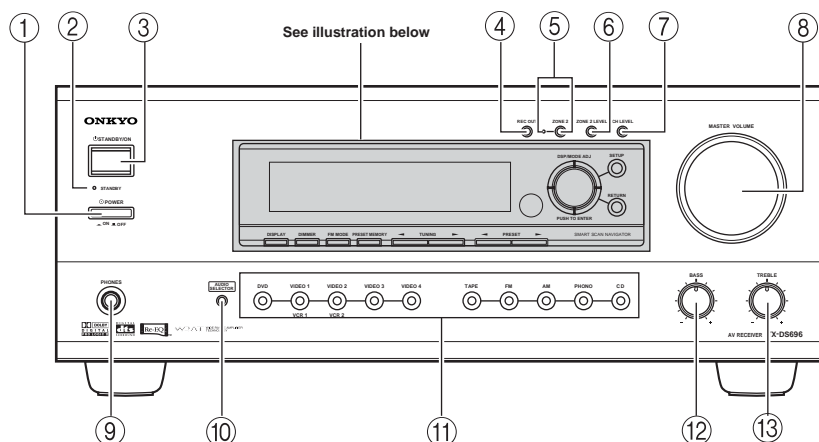

For European model

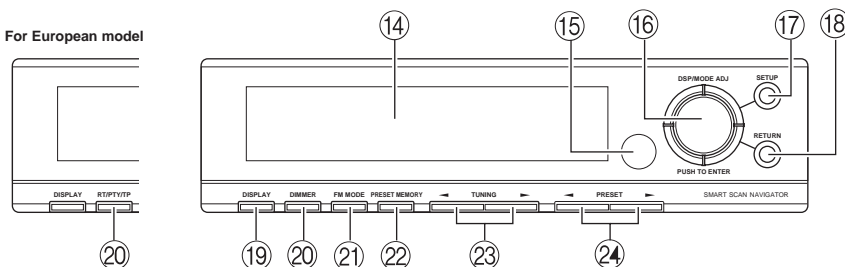

Front panel display

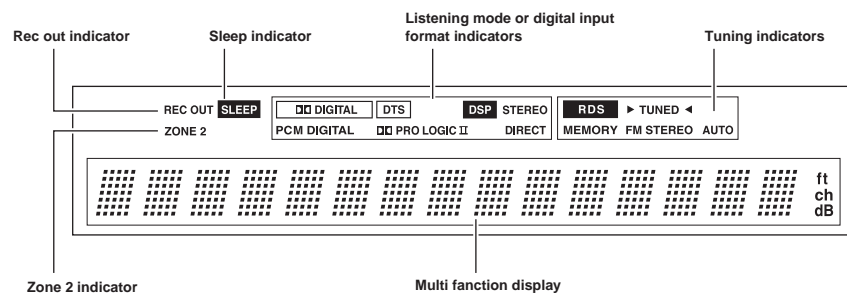

① POWER switch

Turns on and off the main power supply for the TX-DS696.

② STANDBY indicator

Lights when the TX-DS696 is in the standby state and flashes when a signal is received from the remote controller.

③ STANDBY/ON button

Press to turn on the TX-DS696 when in the standby state. Press again to return the TX-DS696 to the standby state.

④ REC OUT button

Press the REC OUT button to output the audio signals to a recording component for recording purposes.

⑤ ZONE 2 button and indicator

Press the ZONE 2 button to enjoy the output from the TX-DS696 in a different room, which is referred to as a remote zone (Zone 2). ZONE 2 indicator lights when a signal is output to the remote zone (Zone 2). When the ZONE 2 indicator is off, then either output to the remote zone is turned off or Rec Out is selected.

⑥ ZONE 2 LEVEL button

Press to enter the mode for adjusting the volume in the remote zone (Zone 2).

⑦ CH LEVEL button

Press to select the channel whose level is to be adjusted.

⑧ MASTER VOLUME dial

The MASTER VOLUME dial is used to control the volume for the main zone. The volume for the remote zone (Zone 2) is independent.

⑨ PHONES jack

This is a standard stereo jack for connecting stereo headphones.

⑩ AUDIO SELECTOR button

This button is used to select the type of audio input signal. Each time pressed, the setting cycles from "AUTO" "Multich" "Analog" and back.

⑪ Input source buttons (DVD, VIDEO 1-4, TAPE, FM, AM, PHONO, and CD)

These buttons are used to select the input source for the main zone. To select the input source for the remote zone (Zone 2) or recording out (Rec Out), first press the Zone 2 or Rec Out button, and then the desired input source button.

⑫ BASS dial

Boosts or cuts the bass response. Bass adjustment is effective only for the front speakers and headphones.

⑬ TREBLE dial

Boosts or cuts the treble response. Treble adjustment is effective only for the front speakers and headphones.

⑭ Front display

⑮ Remote control sensor

⑯ SMART SCAN NAVIGATOR jog dial and indicators

Used to make settings in the Setup menu, change listening mode settings, and more.

⑰ SETUP button

Press to bring up the Setup menu. The OSD menu will appear on the TV monitor as well as the front display on the TX-DS696.

⑱ RETURN button

Press to exit the Main menu level or go back one level up.

⑲ DISPLAY button

The DISPLAY button is used to display information about the current input source signal. Each time you press the display button, the screen changes to show you different information concerning the input signal.

⑳ RT/PTY/TP (European models only) button

This button is only available on European models. Use this button to help tune into the Radio Data System (RDS) for FM broadcasting. RDS was developed within the European Broadcasting Union (EBU) and is available in most European countries. Each time the button is pressed, the display changes from RT (radio text) to PTY (program type) to TP (traffic program) and then back to RT again.

㉑ DIMMER (other than European models) button [30]

Press to set the brightness of the front display. There are 3 settings available: normal, dark, and very dark.

㉒ FM MODE button

If you are listening to an FM radio station in stereo and the sound cuts out or there is a great deal of noise, switch from STEREO to MONO. Each time this button is pressed, the AUTO indication flashes and the stereo mode changes from AUTO to MONO and vice versa. This button also turns on and off the FM MUTE.

㉓ PRESET MEMORY button

This button is used to assign the radio station that is currently tuned in to a preset channel or delete a previously preset station.

㉔ TUNING </> buttons

Use these buttons to change the tuner frequency. The tuner frequency is displayed in the front display and it can be changed in 50 kHz increments for FM and 10 kHz (or 9 kHz) increments for AM.

When FM is selected, you can hold down one of the tuning buttons and then release it to activate the auto-search feature. It will search for a station in the direction of the button you pressed and stop when it tunes into one.

㉕ PRESET </> buttons

When AM or FM is selected as the input source, press one of these buttons to jump to a radio station that you preset using the PRESET MEMORY button. Pressing the right button moves from the most recently preset station to older ones, and pressing the left button moves in the reverse order.

REMOTE CONTROLLER

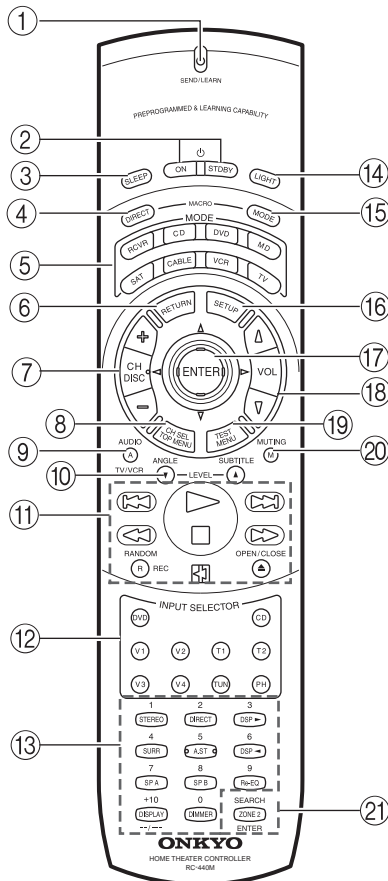

① SEND/LEARN indicator

This indicator acts as a guide when commands are programmed into or sent by the remote controller. It also warns the user when an error is made or battery power is low.

② ON/STDBY button

ON: Turns on the TX-DS696.

STDBY: Places the TX-DS696 in the standby state. Be aware that pressing the STDBY button only places the TX-DS696 in standby and does not turn the power completely off.

③ SLEEP button

Sets the sleep function. The SLEEP button enables you to set the TX-DS696 to turn off automatically after a specified time period.

④ DIRECT MACRO button

For executing and programming the Direct Macro function.

⑤ MODE buttons and indicators

For selecting the component to be operated by the remote controller. When a MODE button is pressed, it will light green for 8 seconds. The selected MODE button will also light whenever any other operation button is pressed to tell you which mode the remote controller is in.

⑥ RETURN button

For entering the selected setting and returning to the previous menu.

⑦ CH/DISC +/- button

When in the RCVR mode, for selecting a tuner preset channel. For selecting the disc to be played back for components with disc changers when in the DVD or CD modes.

⑧ CH SEL/TOP MENU button

CH SEL: For selecting the speaker for level adjustment when in the RCVR mode. Used together with the LEVEL ▲/▼ buttons.

TOP MENU: When in the DVD mode, for displaying the menu screen(s) recorded on DVD media.

⑨ AUDIO/A/TV/VCR button

AUDIO/A: For selecting the audio input signal. The setting changes from "AUTO" to "Multich" to "Analog" and back each time this button is pressed.

TV/VCR: Must be preprogrammed for use in the TV and VCR modes.

⑩ LEVEL ▼/ANGLE and LEVEL ▲/SUBTITLE buttons

LEVEL ▼/▲: Select the speaker whose volume is to be adjusted using the CH SEL button and adjust the volume using the LEVEL ▲/▼ buttons in the RCVR mode.

ANGLE: When in the DVD mode, for selecting a camera angle when a DVD-Video is recorded with multiple angle playback.

SUBTITLE: When in the DVD mode, for selecting one of the subtitle languages recorded on a DVD-Video.

⑪ CD/TAPE/DVD/MD operation buttons

For operating Onkyo components connected to the TX-DS696.

⑫ INPUT SELECTOR buttons

Selects an input source. Same as the input selector buttons on front panel of the TX-DS696. The input source for each buttons is given here. DVD: DVD, CD: CD, V1: VIDEO1, V2: VIDEO2, V3: VIDEO3, V4: VIDEO4, T1: TAPE, T2: Not used with the TX-DS696, TUN: FM/AM, PH: PHONO.

⑬ Numeric key/Listening mode selector/SP A, B/Re-EQ/DISPLAY/DIMMER buttons

1 to 9, +10, --/--, 0: For entering the number of a track.

STEREO, DIRECT, DSP ◀▶, SURR, A.ST: You can select a listening mode.

Re-EQ: Depending on the listening mode, you can turn the cinema re-equalization function on or off.

SP A, SP B: Not used with the TX-DS696.

DISPLAY: For changing the display in the front display.

DIMMER: Adjusts the display brightness. There are three settings available: normal, dark and very dark.

⑭ LIGHT button

For illuminating the buttons of the remote controller.

This button is useful when using the remote controller in dark locations. When pressed, the buttons on the remote controller light green.

The button for the mode currently selected lights brighter than the rest.

⑮ MODE MACRO button

For executing and programming the Macro function.

⑯ SETUP button

For displaying and quitting the Setup menu.

⑰ ENTER/cursor button

When selecting items in the Setup menu, press the upper and lower portions to select item, press the right and left portions to select parameter values or modes, and press ENTER to select item.

⑱ VOL ▲/▼ button

For adjusting the volume.

⑲ TEST/MENU button

TEST: Outputs a test tone for setting speaker levels.

Use this button in conjunction with the LEVEL ▲/▼ and CH SEL buttons to calibrate the speakers levels without entering the Setup menu. When TEST button is pressed, the test noise (pink noise) is output. Use the LEVEL ▲/▼ buttons to increase or decrease the sound level. Use the CH SEL button to change from speaker to speaker.

MENU: When in the DVD mode, this button displays the DVD menu.

⑳ MUTING/M button

Activates the mute function.

㉑ ZONE 2/SEARCH/ENTER button

ZONE 2: When in the RCVR mode, press this button to perform operations on the remote zone (Zone 2).

SEARCH: When in the DVD mode, for finding the specific section on a disc where you want to start playback.

ENTER: When in the MD mode, for confirming the selection.

CONNECTIONS

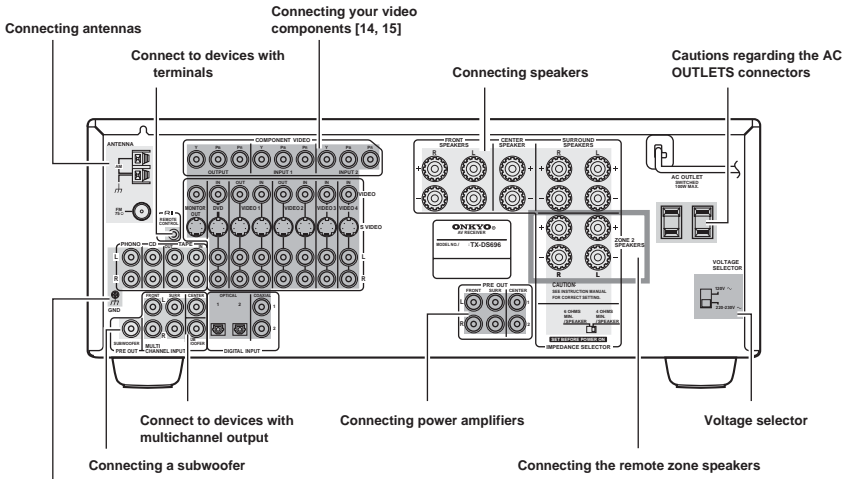

Default setting

Input source	Digital input	Component video	Multichannel
DVD	COAX 1	INPUT 1	Yes
VIDEO 1	COAX 2	INPUT 2	No
VIDEO 2	----	INPUT 1	No
VIDEO 3	OPT 2	INPUT 1	No
VIDEO 4	----	INPUT 1	No
TAPE	----	----	No
FM	----	----	Not applicable
AM	----	----	Not applicable
PHONO	----	----	No
CD	OPT 1	----	No

COAX: Coaxial OPT: Optical ----: No setting : Not applicable

Connecting your audio components

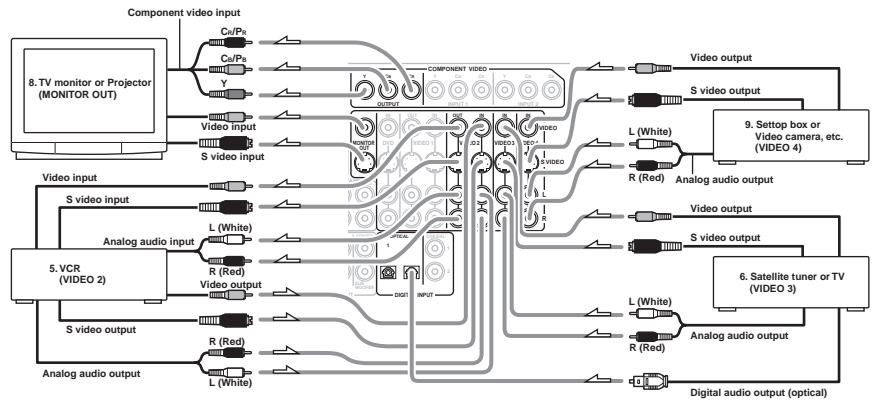
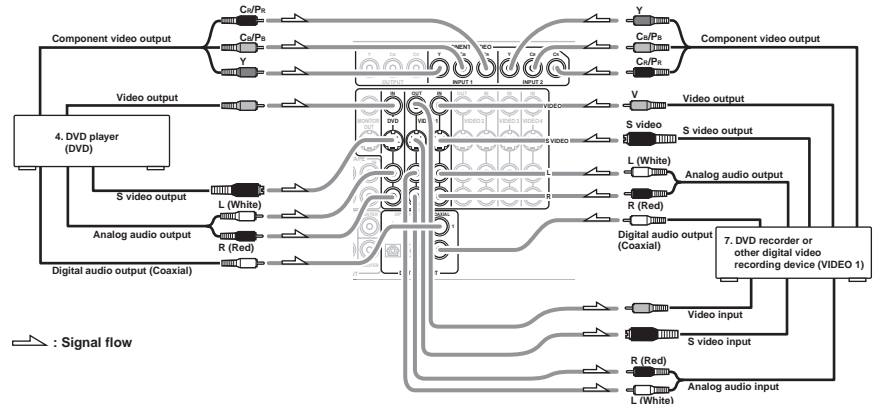
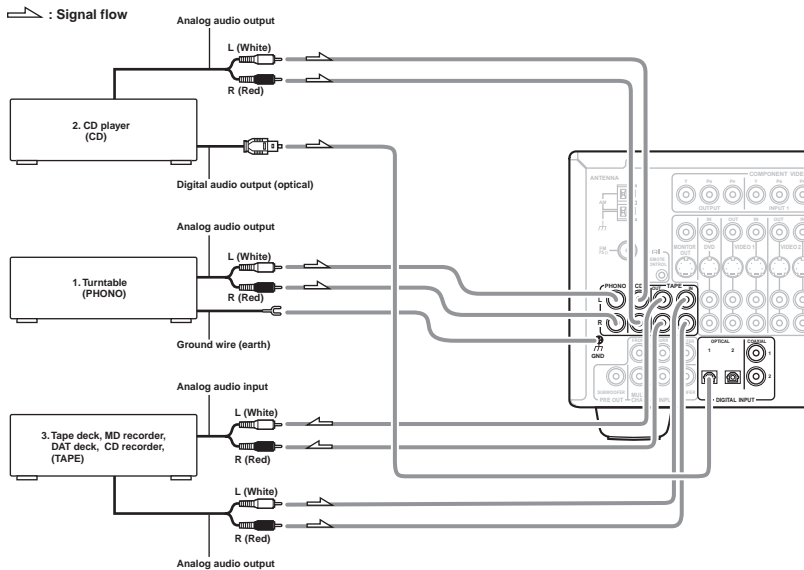

IC BLOCK DIAGRAMS AND DESCRIPTIONS

AK4112AVF(24-bit 96-kHz DIR)

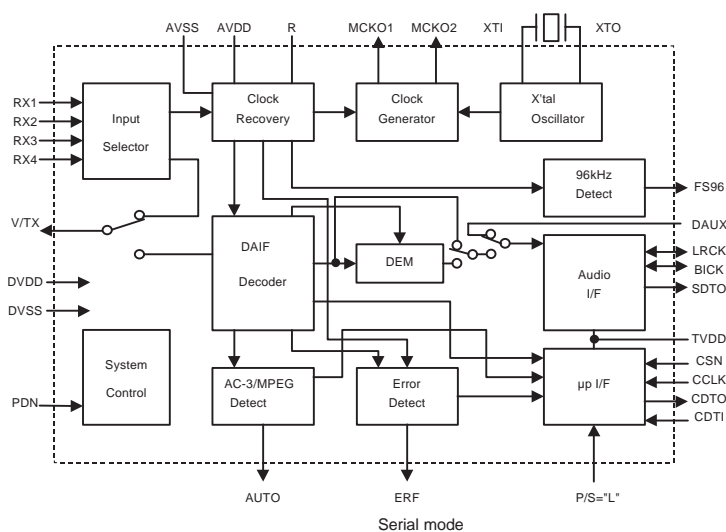
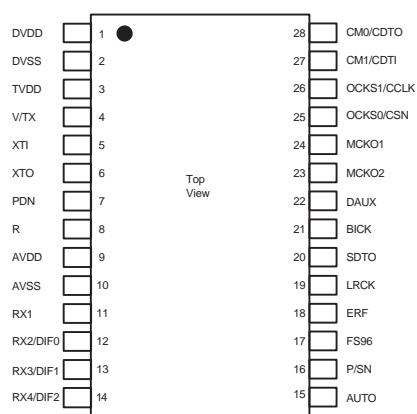

No.	Pin Name	I/O	Function
1	DVDD	-	Digital Power Supply Pin, 3.3V
2	DVSS	-	Digital Ground Pin
3	TVDD	-	Input Buffer Power Supply Pin, 3.3V or 5V
4	V	O	Validity Flag Output Pin in Parallel Mode
5	XTI	I	X'tal Input Pin
6	XTO	O	X'tal Output Pin
7	PDN	I	Power-Down Mode Pin When "L", the AK4112A is powered-down and reset.
8	R	-	External Resistor Pin 18k W +/-1% resistor to AVSS externally.
9	AVDD	-	Analog Power Supply Pin
10	AVSS	-	Analog Ground Pin
11	RX1	I	Receiver Channel 1 This channel is selected in Parallel Mode or default of Serial Mode.
12	DIF0	I	Audio Data Interface Format 0 Pin in Parallel Mode
13	RX2	I	Receiver Channel 2 in Serial Mode
13	DIF1	I	Audio Data Interface Format 1 Pin in Parallel Mode
14	RX3	I	Receiver Channel 3 in Serial Mode
14	DIF2	I	Audio Data Interface Format 2 Pin in Parallel Mode
14	RX4	I	Receiver Channel 4 in Serial Mode
15	AUTO	O	Non-PCM Detect Pin "L": No detect; "H": Detect
16	P/S	I	Parallel/Serial Select Pin "L": Serial Mode; "H": Parallel Mode
17	FS96	O	96kHz Sampling Detect Pin (RX Mode) "H": fs=88.2kHz or more; "L": fs=54kHz or less. (X'tal Mode) "H": XFS96=1; "L": XFS96=0.
18	ERF	O	Unlock & Parity Error Output Pin "L": No Error; "H": Error
19	LRCK	I/O	Output Channel Clock Pin
20	SDTO	O	Audio Serial Data Output Pin
21	BICK	I/O	Audio Serial Data Clock Pin
22	DAUX	I	Auxiliary Audio Data Input Pin
23	MCKO2	O	Master Clock #2 Output Pin
24	MCKO1	O	Master Clock #1 Output Pin
25	OCKS0	I	Output Clock Select 0 Pin in Parallel Mode
25	CSN	I	Chip Select Pin in Serial Mode
26	OCKS1	I	Output Clock Select 1 Pin Parallel Mode
26	CCLK	I	Control Data Clock Pin in Serial Mode
27	CM1	I	Master Clock Operation Mode Pin0 in Parallel Mode
27	CDTI	I	Control Data Input Pin in Serial Mode
28	CM0	I	Master Clock Operation Mode Pin1 in Parallel Mode
28	CDTO	O	Control Data Output Pin in Serial Mode

1: All input pins except internal pull-down pins should not be left floating.

AK4527VQ(24bit 96kHz 6-ch. CODEC)

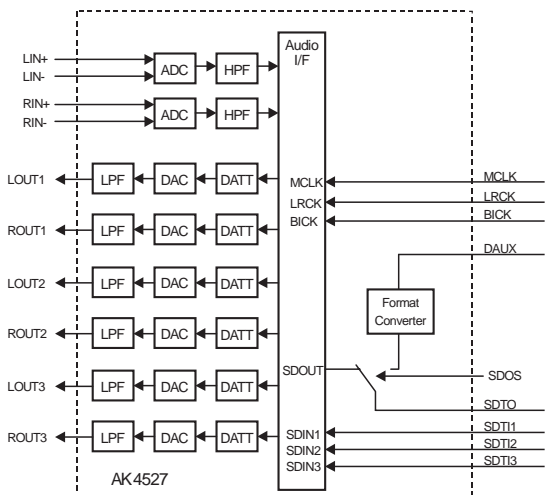

Pin Layout

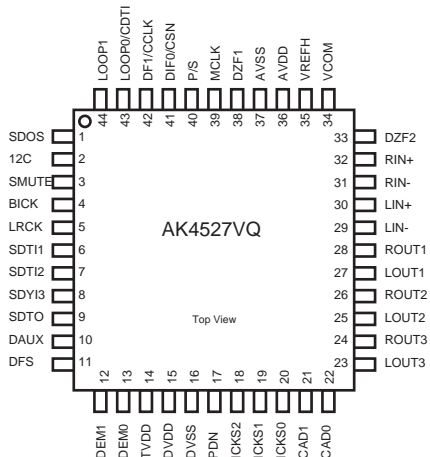

PIN/FUNCTION

No.	Pin Name	I/O	Function
1	SDOS	I	SDTO Source Select Pin (Note 1) "L": Internal ADC output, "H": DAUX input
2	I2C	I	Control Mode Select Pin This pin should be connected to DVSS.
3	SMUTE	I	Soft Mute Pin When this pin goes to "H", soft mute cycle is initialized. When returning to "L", the output mute releases.
4	BICK	I	Audio Serial Data Clock Pin
5	LRCK	I	Input Channel Clock Pin
6	SDT11	I	DAC1 Audio Serial Data Input Pin
7	SDT12	I	DAC2 Audio Serial Data Input Pin
8	SDT13	I	DAC3 Audio Serial Data Input Pin
9	SDTO	O	Audio Serial Data Output Pin
10	DAUX	I	AUX Audio serial Data Input Pin
11	DFS	I	Double Speed Sampling Mode Pin (Note 1) "L": Normal Speed, "H": Double Speed
12	DEM1	I	De-emphasis 1 Pin (Note 2)
13	DEM0	I	De-emphasis 2 Pin (Note 2)
14	TVDD	-	Output Buffer Power Supply Pin, 2.7V-5.5V.
15	DVDD	-	Digital Power Supply Pin, 4.5V-5.5V
16	DVSS	-	Digital Ground Pin, 0V
17	PDN	I	Power-Down & Reset Pin When "L", the control registers are reset to default state. If the state of CAD0-1 changes, then the AK4527 must be reset by PDN.
18	ICKS2	I	Input Clock Select 2 Pin (Note 1) This pin should be connected to DVSS.
19	ICKS1	I	Input Clock Select 1 Pin (Note 1)
20	ICKS0	I	Input Clock Select 0 Pin (Note 1)
21	CAD1	I	Chip Address 1 Pin (Note 1)
22	CAD0	I	Chip Address 0 Pin (Note 1)
23	LOUT3	O	DAC3 Lch Analog Output Pin
24	ROUT3	O	DAC3 Rch Analog Output Pin
25	LOUT2	O	DAC2 Lch Analog Output Pin
26	ROUT2	O	DAC2 Rch Analog Output Pin
27	LOUT1	O	DAC1 Lch Analog Output Pin
28	ROUT1	O	DAC1 Rch Analog Output Pin
29	LIN-	I	Lch Analog Negative Input Pin
30	LIN+	I	Lch Analog Positive Input Pin
31	RIN-	I	Rch Analog Negative Input Pin
32	RIN+	I	Rch Analog Positive Input Pin
33	DZF2	O	Zero Input Detect 2 Pin (Note 3) When the input data of the group 1 follow total 8192 LRCK cycles with "0" input data, this pin goes to "H". This pin is always "L" if P/S="H".
34	VCOM	O	Common Voltage Output Pin, AVDD/2 Large external capacitor around 2.2uF is used to reduce power-supply noise.
35	VREFH	I	Positive Voltage Reference Input Pin, AVDD
36	AVDD	-	Analog Power Supply Pin, 4.5V-5.5V
37	AVSS	-	Analog Ground Pin, 0V
38	DZF1	O	Zero Input Detect 1 Pin (Note 3) When the input data of the group 1 follow total 8192 LRCK cycles with "0" input data, this pin goes to "H". This pin is always "L" if P/S="H".
39	MCLK	I	Master Clock Input Pin
40	P/S	I	Parallel/Serial Select Pin "L": Serial control mode, "H": Parallel control mode
41	DIF0	I	Audio Data Interface Format 0 Pin in parallel control mode
42	DIF1	I	Audio Data Interface Format 1 Pin in parallel control mode
43	LOOP0	I	Lookback Mode 0 Pin in parallel control mode Enables digital look-back from ADC to 3 DACs.
44	LOOP1	I	Lookback Mode 1 Pin (Note 1) Enables all 3 DAC channels to be input from SDT11.

- Notes: 1.SDOS, SMUTE, DFS, ICKS2-0 and LOOP 1 pins are Ored with register data if P/S="L".
 2. DEM1-0 pins are Ored with register data of DEMA1-C0 bits if P/S="L".
 DEM1 pin="H" : DEMA1= DEMB1=DEMC1="1"
 DEM0 pin="H" : DEMA0= DEMB0=DEMC0="1"
 3. The group 1 and 2 can be selected by DZFM2-0 bits if P/S="L".
 4. All input pins should not be left floating.

BA7625(Video Select Switch)

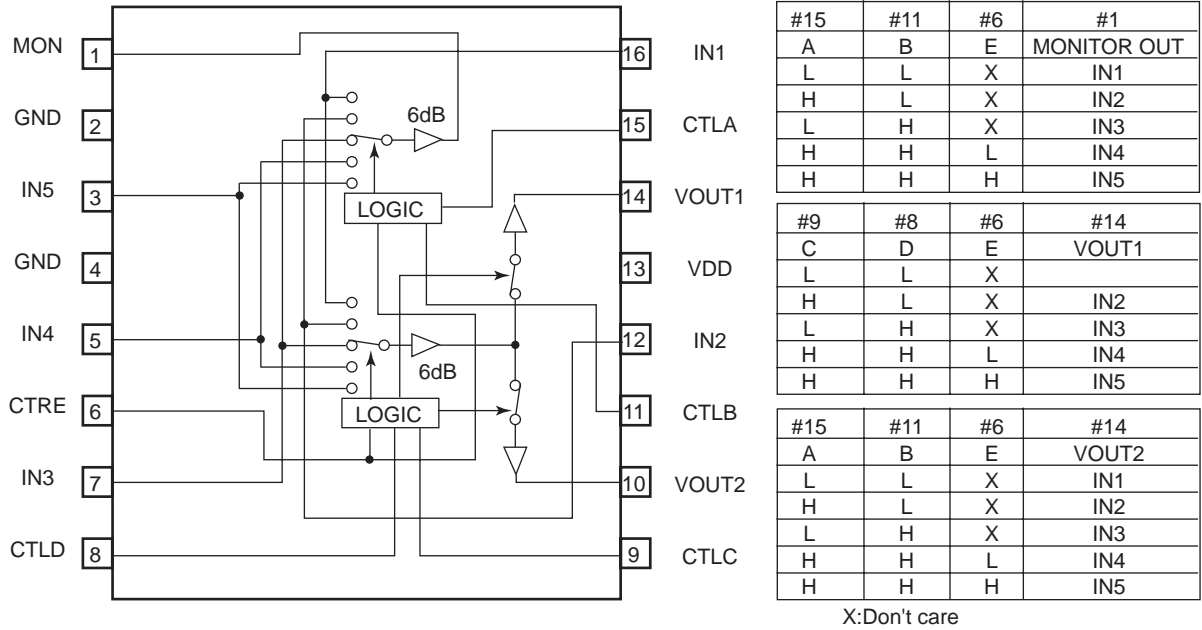

NJM2296D(Dual Video 6dB Amplifier with 75ohm Driver)

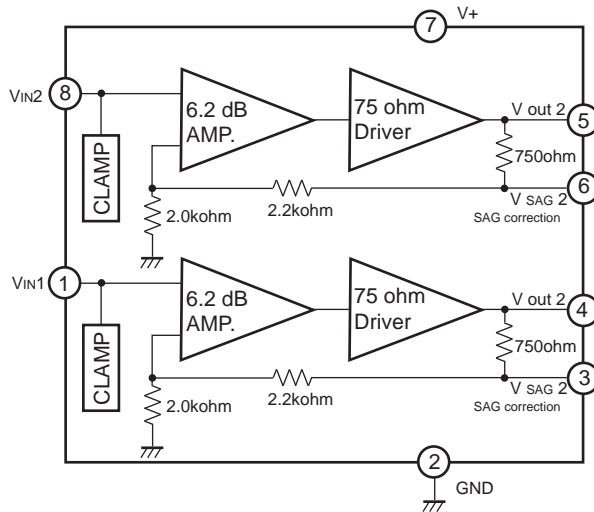

BU1923(RDS Decoder) BLOCK DIAGRAM

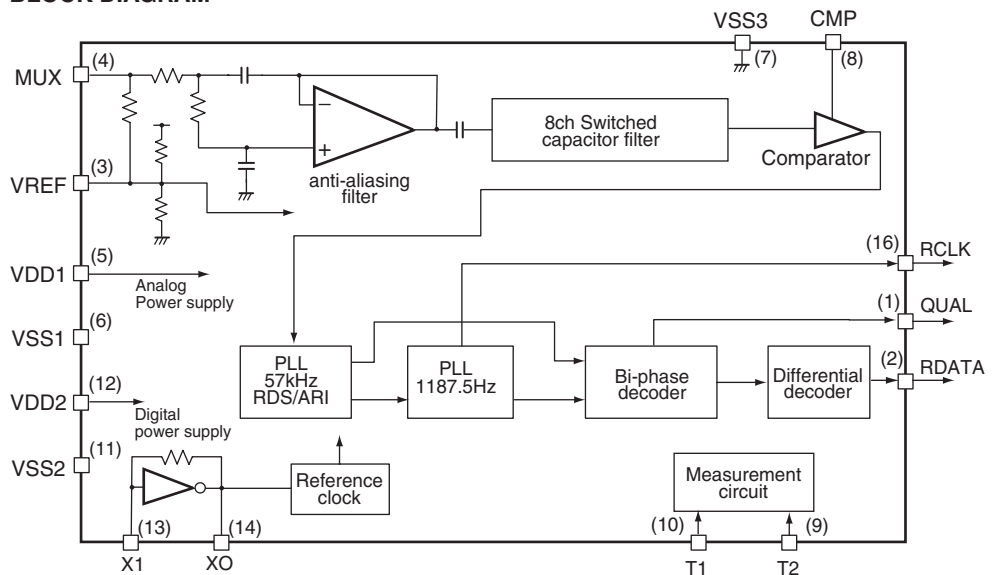

CS49326-CL(DIR)

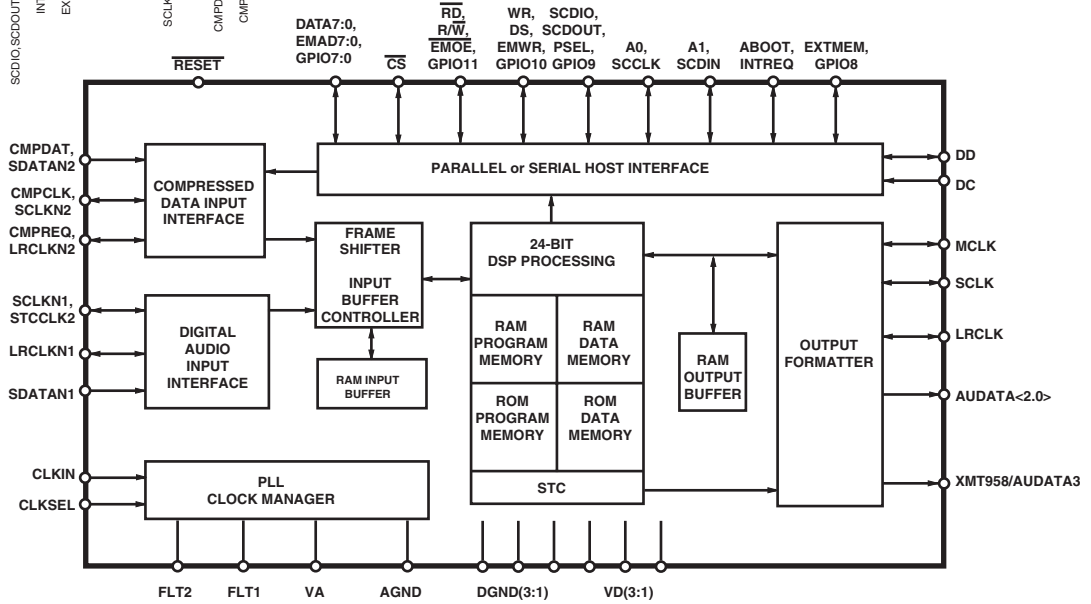
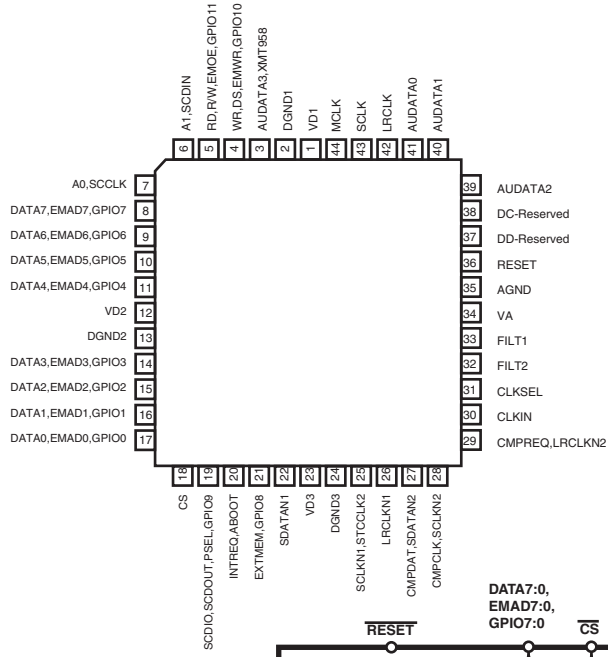

LC74761-9189(TV Character/Pattern Indicator)

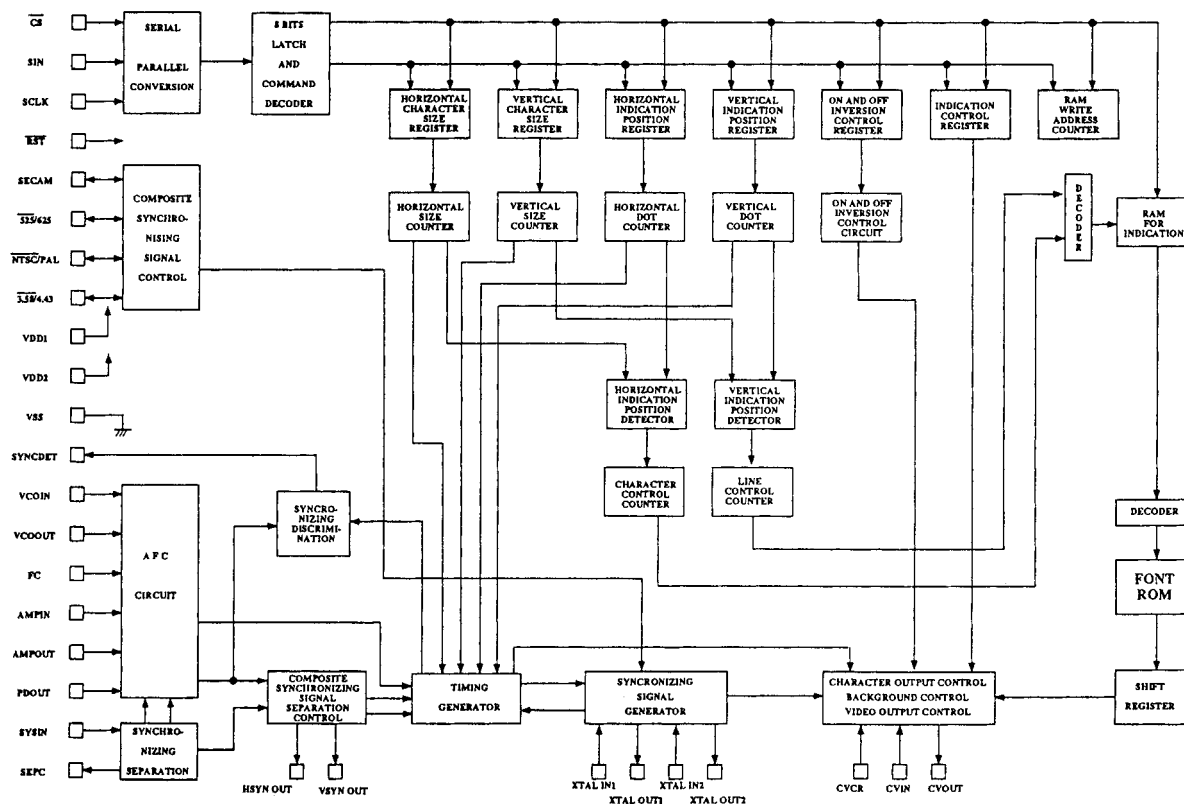

Pin No.	Symbol	Description	Pin No.	Symbol	Description
1	VSS	Ground pin	16	CVOUT	Composite video signal output pin
2	XTAL IN1	Crystal resonator connection pin for	17	VDD2	Power supply pin for Composite video signal
3	XTAL OUT1	internal synchronizing signal generation	18	CVIN	Composite video signal input pin
4	HSYNOUT	Horizontal synchronizing signal output pin	19	CVCR	Chroma signal input pin for SECAM
5	XTAL IN2	Crystal resonator connection pin for	20	SYNCIN	Video signal input pin for internal synchronizing separation circuit
6	XTAL OUT2	internal synchronizing signal generation	21	SEPC	Bias output pin for internal synchronizing separation circuit
7	VSYNOUT	Vertical synchronizing signal output pin	22	VSS	Ground pin
8	CS	Chip enable input pin for serial data input	23	PDOUT	Voltage output pin for AFC circuit
9	SIN	Serial data input pin	24	AMPIN	Filter connection pin
10	SCLK	Clock input pin for serial data	25	AMPOUT	
11	SECAM	SECAM mode selector input pin	26	FC	Voltage output pin for AFC circuit
12	525/625	Selector pin for scansion line	27	VCOIN	LC resonator connection pins for VCO
13	NTSC/PAL	Selector pin for NTSC or PAL	28	VCOOUT	
14	3.58/4.43	Selector pin for 3.58MHz or 4.43MHz	29	SYNCDET	External synchronizing signal discrimination output pin
15	RST	System reset input pin	30	VDD1	Power supply pin

TC74VHC541FT(Octal bus buffer)

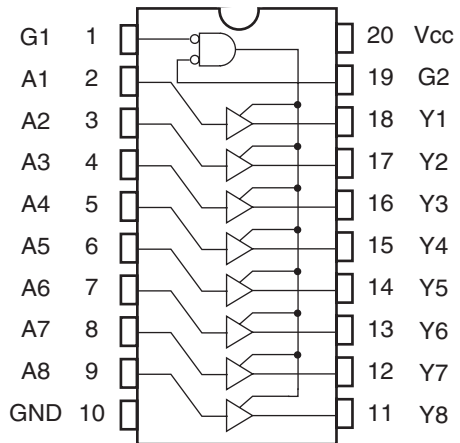

INPUTS			OUTPUT
$\overline{G1}$	$\overline{G2}$	A_n	
H	X	X	Z
X	H	X	Z
L	L	H	H
L	L	L	L

X :Don't care
Z :High impedance

TC9162AF(Analog Switch)

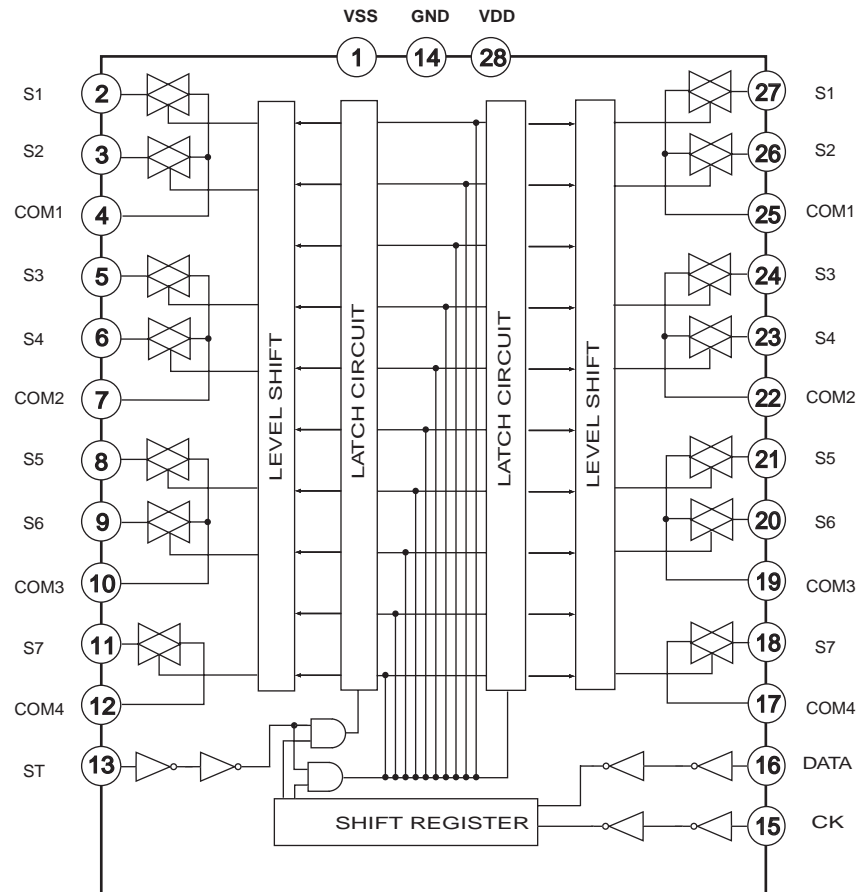

Pin No.	Symbol	Function
1	VSS	Negative power supply
14	GND	Ground
28	VDD	Positive power supply
2,3,5,6,8,9,11	S1-S7	Input/output terminals
27,26,24,23,21,20,18	S1-S7	Input/output terminals
4,7,10,12	COM1 - COM4	Common terminals
25,22,19,17	COM1 - COM4	Common terminals
13	ST	Strobe input terminal for data reading
15	CK	Clock input terminal for data transfer
16	DATA	Data input terminal for switch

TC9163AF(Analog Switch)

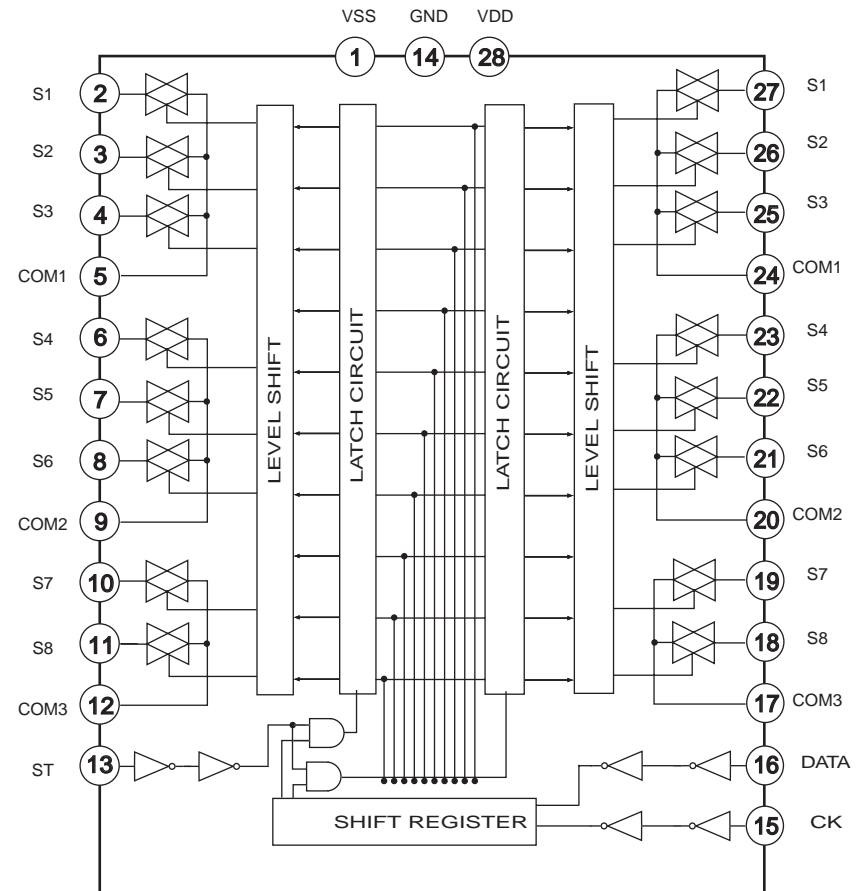

Pin No.	Symbol	Function
1	VSS	Negative power supply
14	GND	Ground
28	VDD	Positive power supply
2,3,4,6,7,8,10,11	S1-S8	Input/output terminals
27,26,25,23,22,21,19,18	S1-S8	Input/output terminals
5,9,12	COM1 - COM3	Common terminals
24,20,17	COM1 - COM3	Common terminals
13	ST	Strobe input terminal for data reading
15	CK	Clock input terminal for data transfer
16	DATA	Data input terminal for switch

TC9164AF(Analog Switch)

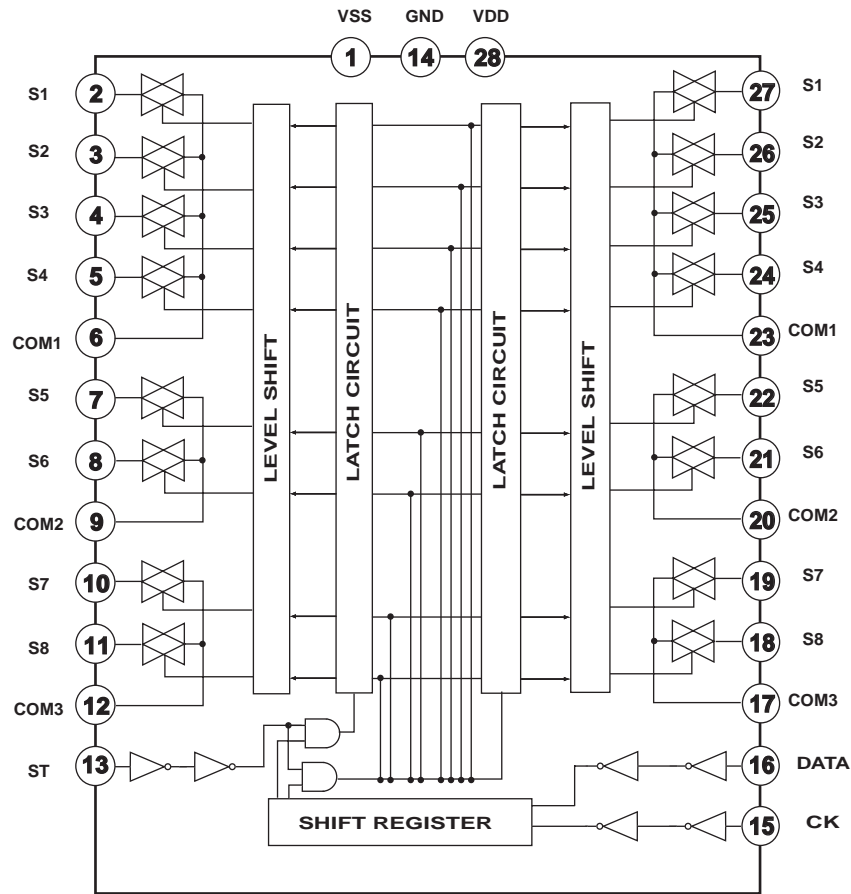

Pin No.	Symbol	Function
1	VSS	Negative power supply
14	GND	Ground
28	VDD	Positive power supply
2,3,4,6,7,8,10,11	S1-S8	Input/output terminals
27,26,25,23,22,21,19,18	S1-S8	Input/output terminals
5,9,12	COM1-COM3	Common terminals
24,20,17	COM1-COM3	Common terminals
13	ST	Strobe input terminal for data reading
15	CK	Clock input terminal for data transfer
16	DATA	Data input terminal for switch

TC9274N(Analog Switch Array)

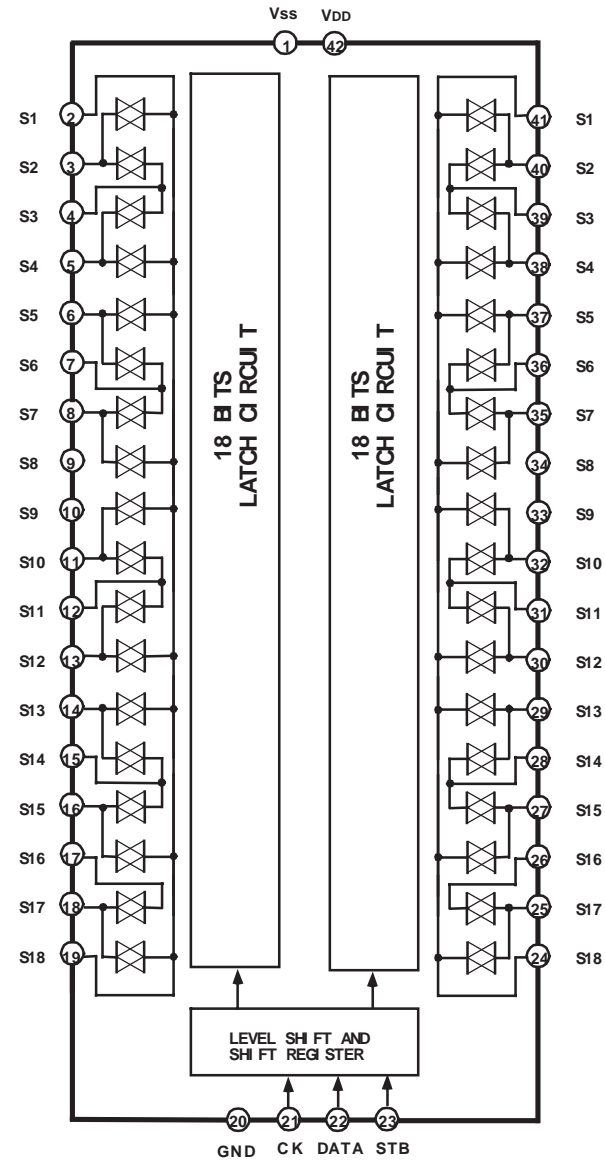

TC9482N(6 channel electronic volume)

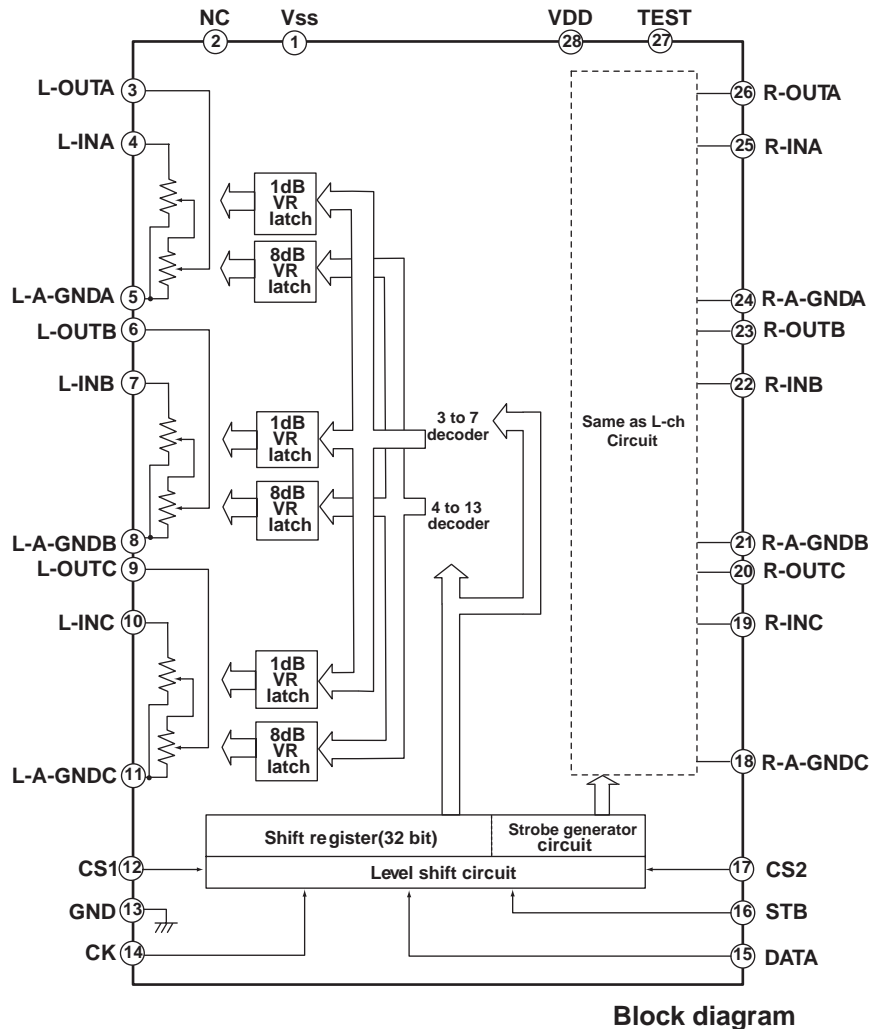

Terminal description

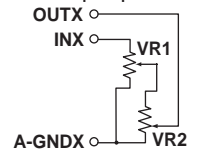
Pin No.	Symbol	Pin name	Pin No.	Symbol	Pin name
1	VSS	Negative power supply pin	5	L-A-GNDA	Analog ground pins
28	VDD	Positive power supply pin	24	R-A-GNDA	
3	L-OUTA	Volume output pins 	8	L-A-GNDB	
26	R-OUTA		21	R-A-GNDB	
6	L-OUTB		11	L-A-GNDC	
23	R-OUTB		18	R-A-GNDC	
9	L-OUTC		12	CS1	Chip select input pins
20	R-OUTC		17	CS2	
4	L-INA	Volume input pins	14	CK	Clock input pin
25	R-INA		15	DATA	Data input pin
7	L-INB		16	STB	Strobe input pin
22	R-INB		13	GND	Digital ground pin
10	L-INC		27	TEST	Test pin
19	R-INC		2	NC	No connection

MAIN MICROPROCESSOR TERMINAL DESCRIPTIONS

Pin No.	Symbol	I/O	Descriptions
3	AMUT	O	Audio muting output pin.
4	VB	O	Output B pin to control video signal.
5	VA	O	Output A pin to control video signal.
6	EVDD		Power supply pin. Connect to +5V.
7	EVSS		Ground pin.
8	GSW	O	Gain control signal output pin for subwoofer.
9	GFS	O	Gain control output signal pin to front, surround, and center channels.
10	~CODECPD	O	Power down output pin to Codec IC.
11	INTREQ	I/O	Interrupter and abort signal input/output pin of DSP IC.
12	DSPDI	I	Serial data input pin from DIR and DSP ICs.
13	DSPDO	O	Serial data output pin from DIR and DSP ICs.
14	DSPSCK	O	Serial clock output pin to DIR and DSP ICs.
15	DSPCS	O	Chip select output pin to DSP IC.
16	CSROM/~SRAM	O	Change-over pin of RAM and ROM, ROM at H.
17	A15	O	ROM address 15
19	A16	O	ROM address 16
20	A17	O	ROM address 17
21	~DSPRST	O	Reset signal output pin to DSP IC.
22	ERF	I	Error flag input pin.
23	AUTO	O	Auto detection input pin of DIR IC.
24	DIRCS	O	Chip select output pin to DIR IC.
25	~DIRPD	O	Power down signal output pin to DIR IC.
31	~RESET	I	System reset input terminal.
32	XT1		Oscillator connection pin of sub system. Not used.
33	XT2		Not used.
35	X2		Ceramic oscillator connection pins.
36	X1		Connect the 20MHz ceramic oscillator between X1 and X2 pins.
37	VSS		Power supply pin. Connect to ground pin.
38	VDD		Power supply pin. Connect to +5V.
39	CLKOUT		Not used.
41	SPB	O	Speaker relay B control signal output pin.
42	SEC1H	O	Amplifier gain control output pin.
43	SPCS	O	Speaker relay control output pin of center and surround channels.
44	SPA	O	Speaker relay A control signal output pin.
45	POWER	O	Power relay control output pin.
46	PROTECT	I	Protection circuit detection input pin.
47	UPLD	O	Up direction LED control output pin of SSC.
48	DNLED	O	Down direction LED control output pin of SSC.
49	LEED	O	Left direction LED control output pin of SSC.

Pin No.	Symbol	I/O	Descriptions
50	RLED	O	Right direction LED control output pin of SSC.
51	~SBMRST	O	Reset signal output pin to sub microprocessor.
52	SBMCLK	O	Clock signal output pin to transmit to the sub microprocessor.
53	SBMDO	O	Data signal output pin to transmit to the sub microprocessor.
54	SBMDI	I	Data signal input pin to transmit from the sub microprocessor.
55	BVDD		Power supply pin. Connect to +5V.
56	BVSS		Ground pin.
57	SBMREDY	I	Read signal input pin to transmit from the sub microprocessor.
58	HD	I	Detection pin when insert the headphones.
59	Z2LED	O	Zone 2 LED control output pin.
61	HPMUT	O	Muting output pin to the headphone circuit.
64	TMUT	O	Muting output pin to the tuner block.
66	FDA	O	Data signal output pin to Selector, Configuration, Multi channel, and Multi source control ICs.
67	FCL	O	Clock signal output pin to Selector, Configuration, Multi channel, and Multi source control ICs.
68	FSTB	O	Strobe signal output pin to Selector, Configuration, Multi channel, and Multi source control ICs.
69	RDSSIG/12VB	I/O	Quality check input pin of RDS demodulator signal.
70	RDSDA/12VA	I/O	Data input pin from RDS decoder.
71	AVDD		Power supply pin. Connect to +5V.
72	AVSS		Ground pin.
73	AVREF		Reference voltage input pin.
74	VOLH	I	Voltage detection input pin of speaker terminal.
75	~ST	I	Stereo broadcast detection input pin.
76	~SD	I	Station input pin.
77	12VTRGEN	I	Initializing input terminal for 12V trigger.
78	RDSEN	I	Initializing input terminal for RDS broadcast.
79	PLAEN	I	Initializing input terminal for PAL/NTSC.
80	AREA1	I	Initializing input terminal for broadcast area.
81	AREA2	I	Initializing input terminal for broadcast area.
88	~POFF	I	Power failure detection input pin.
89	RDSSCK	I	Clock signal input pin from RDS decoder.
90	PLLSTB	O	Chip enable signal output pin to PLL IC.
91	PLLDA	O	Data signal output pin to PLL IC.
92	PLLCL	O	Clock signal output pin to PLL IC.
93	VLSTB	O	Strobe signal output pin to electrical volume IC.
94	SI	I	Signal input pin to write the program.
95	SO	O	Signal output pin to write the program.
96	SCL	O	Clock signal output pin to write the program.
99	VOLCL/HS	O	Clock signal output pin to the electrical volume IC.
100	VOLDA	O	Data signal output pin to the electrical volume IC.

SUB MICROPROCESSOR TERMINAL DESCRIPTIONS

Pin No.	Symbol	I/O	Description
1	VDD		Power supply terminal. Connect to 5V.
2	VSS		Ground terminal.
3	X1		Ceramic oscillator connection terminals for main system.
4	X2		Connect the 5MHz ceramic oscillator between #3 and #4.
5	IC/VPP		Power supply terminal for flash memory IC.
6	-RESET	I	System reset signal input terminal.
7	SUBCL/SCK	I	Clock input terminal to transmit from main microprocessor or to write the program.
8	SUBDO/SDI	I	Data input terminal to transmit from main microprocessor or to write the program.
9	SUBDI/SDD	O	Data output terminal to transmit to main microprocessor or to write the program.
10	SUBLDY	O	Data ready output terminal to transmit to the main microprocessor.
11	VBJ	I	Pulse input terminal from the rotary encoder of volume.
12	VAJ	I	Pulse input terminal from the rotary encoder of volume.
13	SSCBJ	I	Pulse input terminal from the rotary encoder of SSC.
14	SSCAJ	I	Pulse input terminal from the rotary encoder of SSC.
15	-IRIN	I	Signal input terminal to remote controller.
16	-IRF	I	Signal input terminal to remote controller.
17	STBYLED	O	Standby LED control output terminal.
18	AVSS		Ground terminal for A/D converter.
19	K3	I	Operation key connection terminal.
20	K2	I	Operation key connection terminal.
21	K1	I	Operation key connection terminal.
22	K0	I	Operation key connection terminal.
23	VSS0		Ground terminal
24	AVDD		Power supply terminal for A/D converter.
25	VDDD		Power supply terminal. Apply +5V.
26	-SYSIN	I	System code input terminal.
27	-SYSOUT	O	System code output terminal.
28	P35	O	Segment output terminal of P35.
29	P34	O	Segment output terminal of P34.
30	P33	O	Segment output terminal of P33.
31	P32	O	Segment output terminal of P32.
32	P31	O	Segment output terminal of P31.
33	P30	O	Segment output terminal of P30.
34	P29	O	Segment output terminal of P29.
35	P28	O	Segment output terminal of P28.
36	P27	O	Segment output terminal of P27.
37	P26	O	Segment output terminal of P26.
38	P25	O	Segment output terminal of P25.
39	P24	O	Segment output terminal of P24.
40	P23	O	Segment output terminal of P23.

Pin No.	Symbol	I/O	Description
41	P22	O	Segment output terminal of P22.
42	P21	O	Segment output terminal of P21.
43	P20	O	Segment output terminal of P20.
44	P19	O	Segment output terminal of P19.
45	P18	O	Segment output terminal of P18.
46	P17	O	Segment output terminal of P17.
47	P16	O	Segment output terminal of P16.
48	P15	O	Segment output terminal of P15.
49	P14	O	Segment output terminal of P14.
50	P13	O	Segment output terminal of P13.
51	P12	O	Segment output terminal of P12.
52	P11	O	Segment output terminal of P11.
53	P10	O	Segment output terminal of P10.
54	P9	O	Segment output terminal of P9.
55	P8	O	Segment output terminal of P8.
56	P7	O	Segment output terminal of P7.
57	P6	O	Segment output terminal of P6.
58	P5	O	Segment output terminal of P5.
59	VDD2		Power supply terminal. Apply +5V.
60	VLOAD		Negative power supply terminal of FL controller.
61	P4	O	Segment output terminal of P4.
62	P3	O	Segment output terminal of P3.
63	P2	O	Segment output terminal of P2.
64	P1	O	Segment output terminal of P1.
65	16G	O	Grid output terminal of 16G.
66	15G	O	Grid output terminal of 15G.
67	14G	O	Grid output terminal of 14G.
68	13G	O	Grid output terminal of 13G.
69	12G	O	Grid output terminal of 12G.
70	11G	O	Grid output terminal of 11G.
71	10G	O	Grid output terminal of 10G.
72	9G	O	Grid output terminal of 9G.
73	8G	O	Grid output terminal of 8G.
74	7G	O	Grid output terminal of 7G.
75	6G	O	Grid output terminal of 6G.
76	5G	O	Grid output terminal of 5G.
77	4G	O	Grid output terminal of 4G.
78	3G	O	Grid output terminal of 3G.
79	2G	O	Grid output terminal of 2G.
80	1G	O	Grid output terminal of 1G.

A B C D E

MAIN MICROPROCESSOR

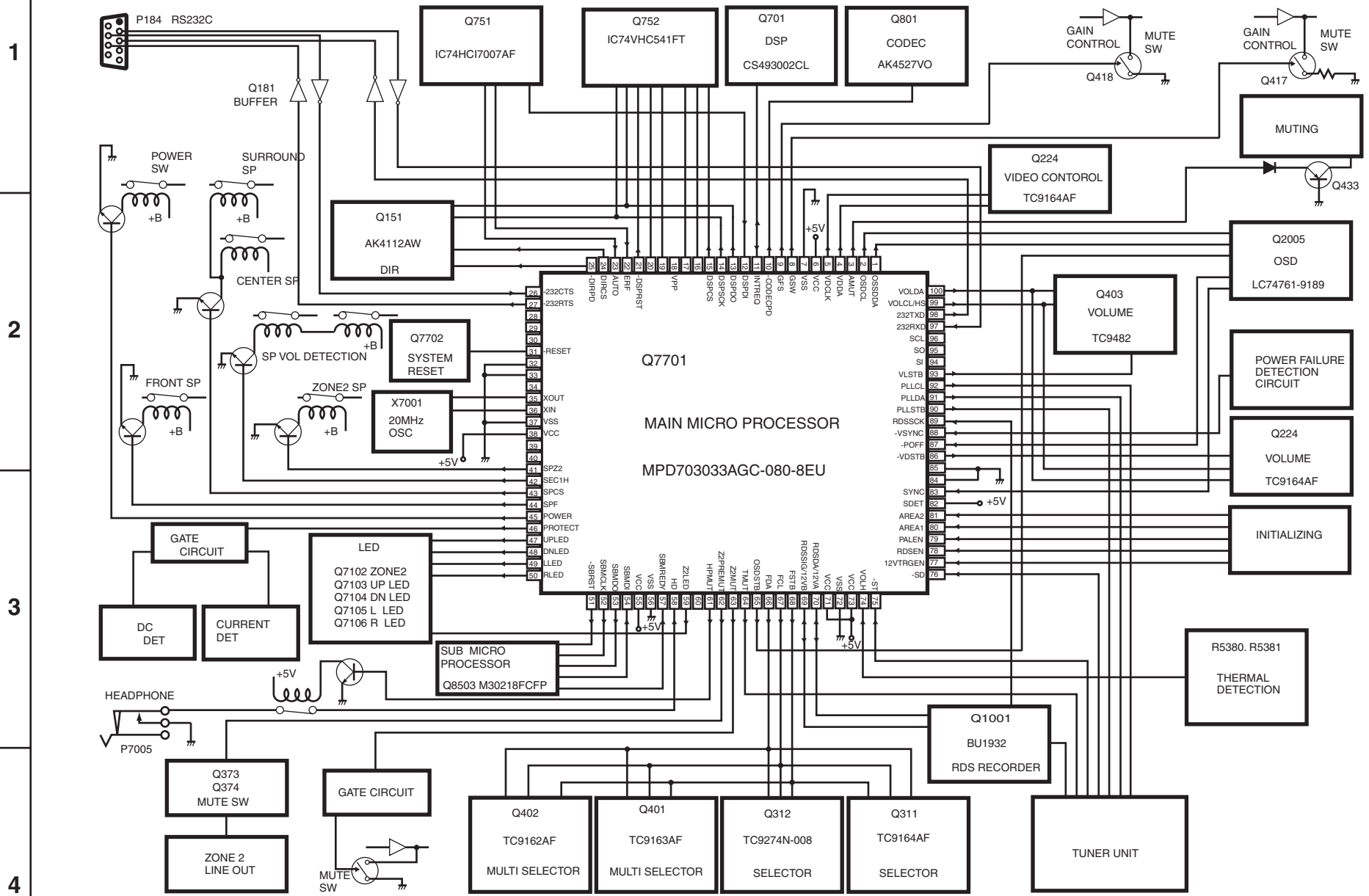

MAIN MICROPROCESSOR TERMINAL DESCRIPTIONS

Pin No.	Symbol	I/O	Descriptions
1	DSPDA	O	Serial data output pin to DSP IC.
2	DSPCL	O	Serial clock output pin to OSD IC.
3	AMUT	O	Audio muting output pin.
4	VDDA	O	Data signal output pin to analog switch for video switch control.
5	VDCLK	O	Clock signal output pin to analog switch for video switch control.
6	EVDD		Power supply pin. Connect to +5V.
7	EVSS		Ground pin.
8	GSW	O	Gain control signal output pin for subwoofer.
9	GFS	O	Gain control output signal pin to front, surround, and center channels.
10	-CODECPD	O	Power down output pin to Codec IC.
11	INTREQ	I/O	Interrupter and abort signal input/output pin of DSP IC.
12	DSPDI	I	Serial data input pin from DIR and DSP ICs.
13	DSPDO	O	Serial data output pin from DIR and DSP ICs.
14	DSPSCK	O	Serial clock output pin to DIR and DSP ICs.
15	DSPCS	O	Chip select output pin to DSP IC.
21	-DSPRST	O	Reset signal output pin to DSP IC.
22	ERF	I	Error flag input pin.
23	AUTO	O	Auto detection input pin of DIR IC.
24	DIRCS	O	Chip select output pin to DIR IC.
25	-DIRPD	O	Power down signal output pin to DIR IC.
26	-232CTS	I	Transmission judge input pin of RS232C signal.
27	-232RTS	O	Communication request signal output pin of RS232C signal.
31	-RESET	I	System reset input terminal.
32	XT1		Oscillator connection pin of sub system. Not used.
33	XT2		Not used.
35	X2		Ceramic oscillator connection pins.
36	X1		Connect the 20MHz ceramic oscillator between X1 and X2 pins.
37	VSS		Power supply pin. Connect to ground pin.
38	VDD		Power supply pin. Connect to +5V.
39	CLKOUT		Not used.
41	SPZ2	O	Speaker relay control signal output pin for Zone 2.
42	SEC1H	O	Amplifier gain control output pin.
43	SPCS	O	Speaker relay control output pin of center and surround channels.
44	SPF	O	Speaker relay control output pin of front channel.
45	POWER	O	Power relay control output pin.
46	PROTECT	I	Protection circuit detection input pin.
47	UPLD	O	Up direction LED control output pin of SSC.
48	DNLED	O	Down direction LED control output pin of SSC.
49	LEED	O	Left direction LED control output pin of SSC.
50	RLED	O	Right direction LED control output pin of SSC.
51	-SBMRST	O	Reset signal output pin to sub microprocessor.
52	SBMCLK	O	Clock signal output pin to transmit to the sub microprocessor.
53	SBMDO	O	Data signal output pin to transmit to the sub microprocessor.
54	SBMDI	I	Data signal input pin to transmit from the sub microprocessor.

Pin No.	Symbol	I/O	Descriptions
55	BVDD		Power supply pin. Connect to +5V.
56	BVSS		Ground pin.
57	SBMRDY	I	Read signal input pin to transmit from the sub microprocessor.
58	HD	I	Detection pin when insert the headphones.
59	Z2LED	O	Zone 2 LED control output pin.
61	HPMUT	O	Muting output pin to the headphone circuit.
62	VMUT	O	Muting output pin to the video circuit.
63	Z2MUT	O	Muting output pin to the zone 2 circuit.
64	TMUT	O	Muting output pin to the tuner block.
65	OSDSTB	O	Chip select signal output pin to OSD IC.
66	FDA	O	Data signal output pin to Selector, Configuration, Multi channel, and Multi source control ICs.
67	FCL	O	Clock signal output pin to Selector, Configuration, Multi channel, and Multi source control ICs.
68	FSTB	O	Strobe signal output pin to Selector, Configuration, Multi channel, and Multi source control ICs.
69	RDSSIG/12VB	I/O	Quality check input pin of RDS demodulator signal.
70	RDSDA/12VA	I/O	Data input pin from RDS decoder.
71	AVDD		Power supply pin. Connect to +5V.
72	AVSS		Ground pin.
73	AVREF		Reference voltage input pin.
74	VOLH	I	Voltage detection input pin of speaker terminal.
75	-ST	I	Stereo broadcast detection input pin.
76	-SD	I	Station input pin.
77	12VTRGEN	I	Initializing input terminal for 12V trigger.
78	RDSEN	I	Initializing input terminal for RDS broadcast.
79	PLAEN	I	Initializing input terminal for PAL/NTSC.
80	AREA1	I	Initializing input terminal for broadcast area.
81	AREA2	I	Initializing input terminal for broadcast area.
82	SDET	I	S video signal detection input pin.
83	SYNC	I	Judge input pin for external synchronizing of OSD.
86	VDSTB	O	Strobe output pin of analog switch for video controller.
87	-VSYNC	I	Vertical synchronizing signal input pin.
88	-POFF	I	Power failure detection input pin.
89	RDSSCK	I	Clock signal input pin from RDS decoder.
90	PLLSTB	O	Chip enable signal output pin to PLL IC.
91	PLLDA	O	Data signal output pin to PLL IC.
92	PLLCL	O	Clock signal output pin to PLL IC.
93	VLSTB	O	Strobe signal output pin to electrical volume IC.
94	SI	I	Signal input pin to write the program.
95	SO	O	Signal output pin to write the program.
96	SCL	O	Clock signal output pin to write the program.
97	232RXD	I	Transmission judge input pin of RS232C signal.
98	232TXD	O	Communication request signal output pin of RS232C signal.
99	VOLCL/HS	O	Clock signal output pin to the electrical volume IC.
100	VOLDA	O	Data signal output pin to the electrical volume IC.

SUB MICROPROCESSOR

OPERATION KEY

	RETURN	SET UP	RECOUT	ZONE 2	CH LEVEL	Z2 VOL
	DIMMER	TAPE	F M	A M	PHONO	C D
	DVD	VIDEO 1	VIDEO 2	VIDEO 3	VIDEO 4	AUDIO SEL
	FM MODE	MEMORY	< TUNING	TUNING >	< PRESET	PRESET >

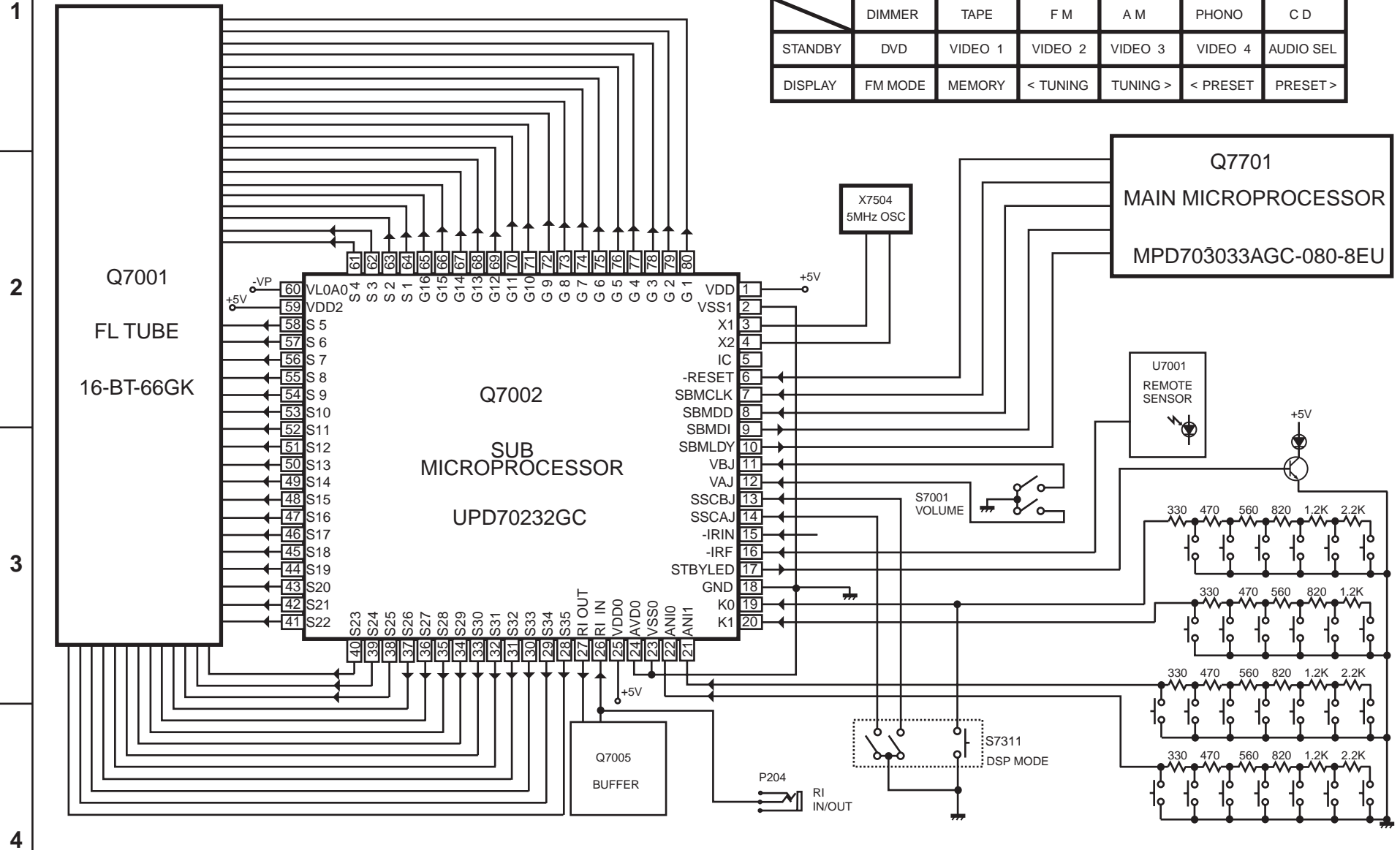

ABOUT DEBUG MODE

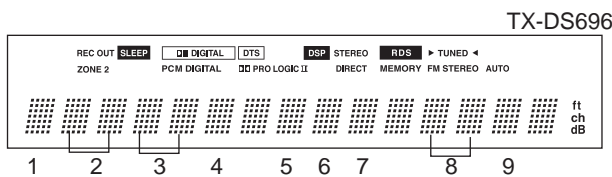
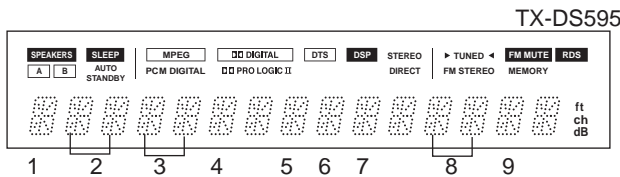

1. How to enter the debug mode
 Press and hold down the AUDIO SEL button, then press the STANDBY/ON button to display "DEBUG MODE IN". After 5 second the unit enters the DEBUG mode. When there is the error that can judge by the microprocessor, the error message is displayed for 3 seconds.

DSPREAD ERROR: Problem of interface between DSP and microprocessor.
 DSPLOCK ERROR: Problem of lock of DSP IC.

On all occasions the microprocessor resets DSP, and DSP is restarted.

2. How to investigate the unit by the debug mode
 Apply the signal that the trouble occurs, and compare with the example of display or the normal unit. If there is difference on the display, you are able to check the rejection by the explanation below. If there is not difference, the input signal comes to DSP IC and the format of signal is recognized. Check the signal from the DSP output to the speaker output.

3. Explanation of Display

1. DIR ERROR: Check of digital signal of DIR IC (AK4112).
 L:There is the digital signal. H:No digital signal.
 When apply the digital signal, the display is "L".
 Check the circuit from digital input to DIR IC and the connection between ERF (#18) of DIR and microprocessor.

2. DIR STATUS 1: It displays the status of Addr03H that AK4112 reads from the digital signal. It shows the sampling frequency, and pre emphasis etc. When the display is difference to the table below, check the signals of DSPCL and DSPDA to confirm the communication between the microprocessor and CDTO/SCDO(#28) of AK4112.

3. DIR STATUS 2: It displays the status of Addr0DH that AK4112 reads from the digital signal. It shows the constants of input signal (DD,DTS,MPEG etc.). When the display is difference to the table below, check the signals of DSPCL and DSPDA to confirm the communication between the microprocessor and CDTO/SCDO(#28) of AK4112.

4. DIR analog/digital judgment
 It displays the result of judgment about input signal by the microprocessor. D:Digital A:Analog

5-7. Addr15 -17 :These displays show the port condition of the flash memory control. "L" except Japanese model.

8. Judgment of DSP input signal
 It displays the result of detection about the input signal by DSP IC. Refer to the table below. When the display differs, check the DSP IC and circumference of DSP IC.

Digital Signal Detection		
DIR	STTS2	DSP
00	00	Null
01	01	Dolby Digital
02	02	Reserved
03	03	Pause
04	04	MPEG1 L1
05	05	MPEG1 L23/MPEG2 w/e
06	06	MPEG2 w/e
07	07	MPEGAAC
08	08	MPEG2 L1
09	09	MPEG2 L2/3
0A	0A	Reserved
0B	0B	DTS1(512)
0C	0C	DTS2(1024)
0D	0D	DTS3(2048)
	20	Silent
	21	DTS LD
	22	DTS CD
	23	Linear PCM

9. DSP DECODE
 When there is the input signal in DSP IC.
 "1" : When decode the signal.
 "0": When does not decode the signal.

"0":When there is not the input signal in DSP IC.

When the digital signal is applied in DSP IC, the display is "0".
 DSP IC does not operate.
 Check the signals to the pins 22, 25, and 26 of DSP IC.
 Is there the signal to pin 20 of DIR IC?

	DIR ERROR	DIR STATUS1	DIR STATUS2	ANA/DIG	ADDR15	ADDR16	ADDR17	Judgment	DECODE
DOLBY DIGITAL	L	34 or B4	01	D	L	L	H	01	1
MPEG AAC *1	L	34 or B4	07	D	L	H	L	07	1
DTS DVD	L	34 or B4	0B	D	H	L	L	0B	1
PCM 48K	L	04	**	D	L	L	L	23	1
PCM 96K	L	03 or 05	**	D	L	L	H	23	1
ANALOG	L	**	**	A	H	L	H	23	1

*1: Japanese model only **:State of last input

FL TUBE VIEW

15-BT-64GNK(Model TX-DS595)

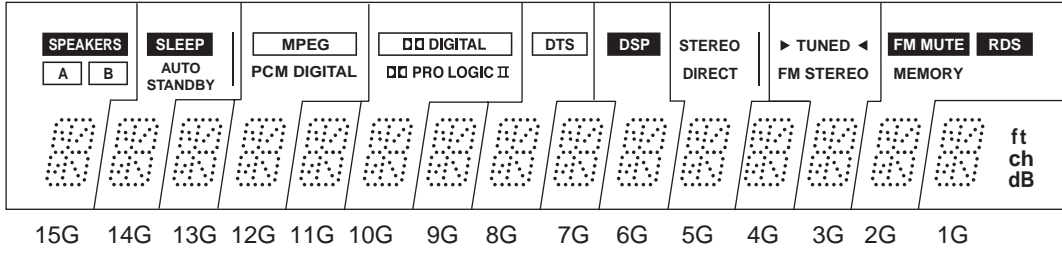
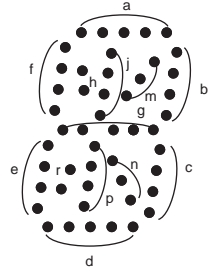

	15G	13G	11G	9G	7G	6G	5G	3G	2G	1G
P1	SPEAKERS	SLEEP	MPEG	DIGITAL	DTS	DSP	STEREO	TUNED	RDS	ft
P2	A	AUTO STANDBY					DIRECT	FM STEREO	FM MUTE	ch
P3	B		PCM DIGITAL	PRO LOGIC II				FM STEREO	MEMORY	dB

PIN NO.	6	6	6	6	6	6	5	5	5	5	5	5	5	5	5	5	5	5	5	4	4	4	4	4	4	4	4	4	4	3	3	3	3	3	3		
CONNECTION	F	F	N	N	P	P	P	P	P	P	P	P	P	P	P	P	P	P	P	N	N	N	N	N	N	N	N	N	N	N	N	N	N	N	N	N	N

PIN NO.	3	3	3	3	2	2	2	2	2	2	2	2	2	2	1	1	1	1	1	1	1	1	1	1	1	1	1	1	1	1	1	1	1	1	1	1	1		
CONNECTION	N	N	N	N	N	N	N	N	N	N	N	N	N	N	N	N	N	N	N	N	N	N	N	N	N	N	N	N	N	N	N	N	N	N	N	N	N	N	N

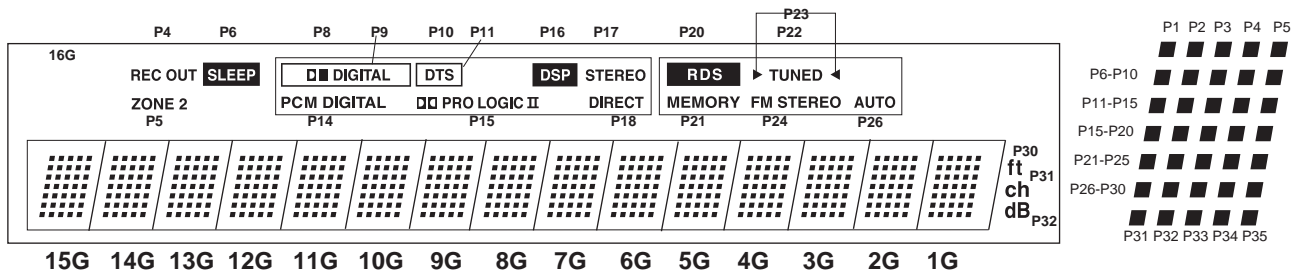

PIN CONNECTION

PIN NO.	6	6	6	6	6	6	5	5	5	5	5	5	5	5	5	5	5	5	5	4	4	4	4	4	4	4	4	4	4	3	3	3	3	3	3	3				
CONNECTION	F	F	N	N	N	P	P	P	P	P	P	P	P	P	P	P	P	P	P	P	P	P	P	P	P	P	P	P	P	P	P	P	P	P	P	P	P	P	P	
PIN NO.	3	3	3	3	2	2	2	2	2	2	2	2	2	2	1	1	1	1	1	1	1	1	1	1	1	1	1	1	1	1	1	1	1	1	1	1	1	1	1	
CONNECTION	P	P	P	P	P	P	N	N	N	N	N	N	N	N	N	N	N	N	N	N	N	N	N	N	N	N	N	N	N	N	N	N	N	N	N	N	N	N	N	N

F1,F2:filament NP: No pin nc: No connection

PRINTED CIRCUIT BOARD PARTS LIST

DSP CIRCUIT PC BOARD (NADG-7066-1H/1I/1J/1K)			CIRCUIT NO.	PART NO.	DESCRIPTION
CIRCUIT NO.	PART NO.	DESCRIPTION		Capacitors	
	ICs		C808	356742209R2	22 μ F, 16V, Elect.
Q101, Q102	22241383R2,	NJM4565M-D,	C809	356724709R2	47 μ F, 6.3V, Elect.
Q405-Q409	22240489R1NE or	MPC4570G2-T1(MST) or	C831-C836	356741009R2	10 μ F, 16V, Elect.
Q802-Q804	22240581R2	NJM4565M	C867-C870	356741019R2	100 μ F, 16V, Elect.
Q121	222740046R2TO	TC74HCU04F		Terminals	
Q151	22241520R2	AK4112AVF	P121	25045645	NPJ-2PDO450
Q401	22240943R2	TC9163AF	P401	25045572	NPJ-6PDBRW387
Q402	22240981R2	TC9162AF	P407	25045567	NPJ-1PDBL382
Q403	22241444R2	TC9482F		Sockets	
Q701	22241518R9	CS493263-CL	P412B	25052580R2	NSCT-14P2477
Q702	22278025DR2NE	MPC2925T	P404	2009990651UL	NSAS-20P0906
Q703	22240935R2	TC7WU04FU		Plugs	
Q704	22278033DR2NE	MPC2933T	JL405B	25055630	NPLG-9P592
Q751	222740077R2TO	TC74HCT7007AF	P403	25055704	NPLG-8P660
Q752	22274541ER2TO	TC74VHC541FT	P409B	25055807	NPLG-18P763
Q7701	22241572R3	MPD703031AGC-081-8EU	P410B	25055708	NPLG-12P664
Q801	22241529R3	AK4527VQ	P411B	25055708	NPLG-12P664
	Photo couplers		P702B	25055807	NPLG-18P763
U121, U122	24120083 or 24120086	GP1FA550RZ or GP1FA551RZ	P7702	25055701	NPLG-5P657
	Transistors				
Q411-Q416	2215410R2	RN1441			
Q417, Q418	2214530R2 or	RN2402 or			
Q433	22162220R2	KRA102S	Q5000-Q5004	2210755,	2SC1775A-E,
Q421-Q426	2215410R2	RN1441	Q5010-Q5014	2210756,	2SC1775A-F,
Q428	2215410R2	RN1441	Q5020-Q5024	2211733 or 2215896	2SC1845-E or KTC3200-BL
Q7702	2214490R2 or 2216210R2	RN1404 or KRC104S	Q5030-Q5034	2211353,	2SA949-O,
	Diodes		Q5040-Q5044	2211354,	2SA949-Y,
D101-D108	223234R2 or	1SS352 or	Q5050-Q5054	2215843 or 2215844	KTA1024-O or KTA1024-Y
D401, D402	223269R2	1SS355	Q5060-Q5064	2211633, 2211634,	2SC2229-O, 2SC2229-Y,
D404	223234R2 or 223269R2	1SS352 or 1SS355		2215854 or 2215853	KTC3206-Y or KTC3206-O
D7701-D7703	223234R2 or	1SS352 or			
D7706	223269R2	1SS355			
D7705	224490620R2	UDZ6.2B	D5000-D5004	224470562	MTZJ5.6B
	Oscillators			Capacitors	
X151	3010323R2	HC-49/U03C 12.288MHz	C5000-C5004	393381017	100 μ F, 50V, Elect.
X701	3010324R2	CSTCV12.2MTJ0C4	C5010-C5014	374721515	150pF+/-10%, 50V, Plastic
X7701	3010342R2	CSTCW2000MX01	C5030-C5034	374721015	100pF+/-10%, 50V, Plastic <P/WT/AWR/GT>
	Coils		C5040-C5044	393343317	330 μ F, 16V, Elect.
L121, L122	231237K470R2	NCH-1479	C5050-C5054	354781009	10 μ F, 50V, Elect.
L152-L154	231237M022R2	NCH-1471	C5070-C5074	354791009	10 μ F, 100V, Elect.
L701	231237K470R2	NCH-1479	C5080-C5084	354791009	10 μ F, 100V, Elect.
L702, L703	231237M022R2	NCH-1471	C5090-C5094	354784709	47 μ F, 50V, Elect.
L801, L802	231237K470R2	NCH-1479	C5120-C5124	393372207	22 μ F, 63V, Elect.
L155, L156	230958R1	BK1608LM182-T	C5130-C5134	393372207	22 μ F, 63V, Elect.
R121, R122	230958R1	BK1608LM182-T	C5401	354780109	1 μ F, 50V, Elect.
	Capacitors			Resistors	
C106	356741009R2	10 μ F, 16V, Elect.	R5130-R5134	443528214	820ohm+/-5%, 1/2W, Metal oxide
C111, C112	356724709R2	47 μ F, 6.3V, Elect.	R5140-R5144	443528214	820ohm+/-5%, 1/2W, Metal oxide
C127, C132	356724709R2	47 μ F, 6.3V, Elect.	R5150-R5154	443521034	10kohm+/-5%, 1/2W, Metal oxide
C152, C158	356724709R2	47 μ F, 6.3V, Elect.	R5160-R5164	443521024	1kohm+/-5%, 1/2W, Metal oxide
C417-C422	356741009R2	10 μ F, 16V, Elect.	R5170-R5174	443528214	820ohm+/-5%, 1/2W, Metal oxide
C435-C440	356721019R2	100 μ F, 6.3V, Elect.	R5180-R5184	443523304	33ohm+/-5%, 1/2W, Metal oxide
C457-C462	356744709R2	47 μ F, 16V, Elect.	R5190-R5194	443521014	100 ohm+/-5%, 1/2W, Metal oxide
C471-C476	356741009R2	10 μ F, 16V, Elect.	R5200-R5204	443521014	100 ohm+/-5%, 1/2W, Metal oxide
C477, C478	374724744	0.47 μ F +/-5%, 50V, Plastic			
C706, C716	356724709R2	47 μ F, 6.3V, Elect.		Resistors	
C719, C723	356724709R2	47 μ F, 6.3V, Elect.	R5230-R5234	443521004	10 ohm+/-5%, 1/2W, Metal oxide
C7703	356724709R2	47 μ F, 6.3V, Elect.	R5240-R5244	443521004	10 ohm+/-5%, 1/2W, Metal oxide
C7705, C7706	356780109R2	1 μ F, 50V, Elect.	R5280-R5284	443521034	10kohm+/-5%, 1/2W, Metal oxide
C7712	356721019R2	100 μ F, 6.3V, Elect.			
C806	356721019R2	100 μ F, 6.3V, Elect.			

POWER AMPLIFIER A PC BOARD (NAAF-7068-1H/1I/1J/1K/1L/1M)

CIRCUIT NO.	PART NO.	DESCRIPTION
	Transistors	
Q5000-Q5004	2210755,	2SC1775A-E,
Q5010-Q5014	2210756,	2SC1775A-F,
Q5020-Q5024	2211733 or 2215896	2SC1845-E or KTC3200-BL
Q5030-Q5034	2211353,	2SA949-O,
Q5040-Q5044	2211354,	2SA949-Y,
Q5050-Q5054	2215843 or 2215844	KTA1024-O or KTA1024-Y
Q5060-Q5064	2211633, 2211634,	2SC2229-O, 2SC2229-Y,
	2215854 or 2215853	KTC3206-Y or KTC3206-O
	Diodes	
D5000-D5004	224470562	MTZJ5.6B
	Capacitors	
C5000-C5004	393381017	100 μ F, 50V, Elect.
C5010-C5014	374721515	150pF+/-10%, 50V, Plastic
C5030-C5034	374721015	100pF+/-10%, 50V, Plastic <P/WT/AWR/GT>
C5040-C5044	393343317	330 μ F, 16V, Elect.
C5050-C5054	354781009	10 μ F, 50V, Elect.
C5070-C5074	354791009	10 μ F, 100V, Elect.
C5080-C5084	354791009	10 μ F, 100V, Elect.
C5090-C5094	354784709	47 μ F, 50V, Elect.
C5120-C5124	393372207	22 μ F, 63V, Elect.
C5130-C5134	393372207	22 μ F, 63V, Elect.
C5401	354780109	1 μ F, 50V, Elect.
	Resistors	
R5130-R5134	443528214	820ohm+/-5%, 1/2W, Metal oxide
R5140-R5144	443528214	820ohm+/-5%, 1/2W, Metal oxide
R5150-R5154	443521034	10kohm+/-5%, 1/2W, Metal oxide
R5160-R5164	443521024	1kohm+/-5%, 1/2W, Metal oxide
R5170-R5174	443528214	820ohm+/-5%, 1/2W, Metal oxide
R5180-R5184	443523304	33ohm+/-5%, 1/2W, Metal oxide
R5190-R5194	443521014	100 ohm+/-5%, 1/2W, Metal oxide
R5200-R5204	443521014	100 ohm+/-5%, 1/2W, Metal oxide
	Resistors	
R5230-R5234	443521004	10 ohm+/-5%, 1/2W, Metal oxide
R5240-R5244	443521004	10 ohm+/-5%, 1/2W, Metal oxide
R5280-R5284	443521034	10kohm+/-5%, 1/2W, Metal oxide

PRINTED CIRCUIT BOARD PARTS LIST

CIRCUIT NO.	PART NO.	DESCRIPTION	CIRCUIT NO.	PART NO.	DESCRIPTION
P6000A-P6004A	25052287	NSCT-4P2184	C901	3500196S	⚠ RE275V-103M,,IS
P6011A	25052295	NSCT-12P2192	C902	3300030	⚠ DE1307E472M-KH,IS
	Plug		C922	354762219	220 μ F,35V,Elect.
P404A	25055154	NPLG-10P138		Resistors	
			R901	431533355	⚠ 3.3Mohm,1/2W,Solid <D>
			R924	443522704	27ohm+/-5%,1/2W,Metal oxide
TERMINAL PC BOARD (NAETC-7069-1H/1I/1J/1K/1L/1M)					
CIRCUIT NO.	PART NO.	DESCRIPTION		Relay	
	IC		RL901	25065561,	⚠ NRL-1P5A-DC12-127,
Q6931	222780565JRC	NJM78M56FA		25065508,	⚠ NRL-1P10A-DC12-093,
	Transistors			25065515 or	⚠ NRL-1P5A-DC12-096 or
Q5303,Q5307	2215864,	KTC3199-GR,		25065526	⚠ NRL-1P5A-DC12-102
	2213285,	2SC1740S-S,		Outlet	
	2213284 or	2SC1740S-R or	P902	25051125	⚠ NSCT-4P912 <P/WT/GT>
	2212115	2SC2458-GR		25051126	⚠ NSCT-4P913 <D>
Q5308,Q5309	2215770,	KRA102M,		25052115	⚠ NSCT-2P2013 <A>
	2213510 or	DTA114ES or		25052381	⚠ NSCT-2P2278 <WR>
	2214350	RN2202		Fuses	
	Diodes		F901	252166	⚠ 6.3A-UL/T237, Fuse <D/WT/WR>
D5306,D5307	223163,	1SS133,	F902	252076 or	⚠ 3.15A-SE-EAK or
	223205 or	1SS270A or		252242	⚠ 3.15A-SE-TL250V, Fuse <P/WT/WR/A/GT>
	223222	WG713A	F903	252075 or	⚠ 2.5A-SE-EAK or
D6932,D6933	22380260,	RL1N4003,		252241	⚠ 2.5A-SE-TL250V,Fuse <P>
	22380032 or	1SR139-100 or		Fuseholders	
	22380035	GP104003E	F901A,F901B	25052133	NSCT-1P2031 <D/WT/WR>
	Capacitors		F902A,F902B	25052133	NSCT-1P2031 <P/WT/A/WR/GT>
C6931	354751029	1000 μ F,25V,Elect.	F903A,F903B	25052133	NSCT-1P2031 <P>
C6933	354741009	10 μ F,16V,Elect.		Switch	
	Resistor		S902	25065437	NSS-22157P <WT/WR>
R6935	441721514	150 ohm+/-5%,2W,Metal oxide		Socket	
	Sockets		P931A	25051230	NSCT-5P1020
P410A,P411A	25051237	NSCT-12P1027		Plugs	
P6931A	25051527	NSCT-16P1314	P901A	25055675 or	NPLG-2P631 or
P7002B	25052242,	NSCT-9P2139,		25056028	NPLG-2P0978
	25050949,	NSCT-9P736,			
	25051313 or	NSCT-9P1102 or			
	25051853	NSCT-9P1640			
	Plug		SPEAKER TERMINAL A PC BOARD (NAETC-7071-1H/1I/1J/1K/1L/1M)		
P6411	25055807	NPLG-18P763	CIRCUIT NO.	PART NO.	DESCRIPTION
	Heatsink		C6840,C6841	374721024	1000pF+/-5%,50V,Plastic <P/WT/A/WR/GT>
Q6931A	27160211	RAD-68	C6844	374721024	1000pF+/-5%,50V,Plastic <P/WT/A/WR/GT>
	Screw			Terminal	
Q6931B	838430107	3TTB+10S(BC),Self-tapping	P6803	25060297	NTM-6PDMN228
				Sockets	
			JL6803B,JL6804B	25050269	NSCT-5P97
PRIMARY CIRCUIT PC BOARD (NAPS-7070-1H/1I/1J/1K/1L/1M)					
CIRCUIT NO.	PART NO.	DESCRIPTION		Capacitors	
	Transistor		C6842,C6843	374721024	1000pF+/-5%,50V,Plastic <P/WT/A/WR/GT>
Q921	2215864,	KTC3199-GR,	C6845,C6846	374721024	1000pF+/-5%,50V,Plastic <P/WT/A/WR/GT>
	2213285.	2SC1740S-S,		Terminal	
	2213284 or	2SC1740S-R or	P6802	25060296	NTM-8PDMN227
	2212115	2SC2458-GR		Socket	
	Diodes		P6805A	25051127	NSCT-8P914
D921-D924	22380260,	RL1N4003,			
	22380032 or	1SR139-100 or			
	22380035	GP104003E			
D925	223163,	1SS133,			
	223205 or	1SS270A or			
	223222	WG713A			
	Power transformer		POWER SWITCH PC BOARD (NASW-7074-1H/1I/1J/1K/1L/1M)		
T902	2301381	⚠ NPT-1358D <D>	CIRCUIT NO.	PART NO.	DESCRIPTION
	2301382	⚠ NPT-1358P <P/A>	S906	25035550	⚠ NPS-111-L512P,Power switch
	2301383	⚠ NPT-1358DG <WT/WR/GT>			

NOTE: THE COMPONENTS IDENTIFIED BY MARK ⚠ ARE CRITICAL FOR RISK OF FIRE AND ELECTRIC SHOCK. REPLACE ONLY WITH PART NUMBER SPECIFIED.

PRINTED CIRCUIT BOARD PARTS LIST

CAUTION: Replacement for transistor of mark *, if necessary must be made from the same beta group (Hfe) as the original type.

POWER AMPLIFIER B PC BOARD (NAAF-7077-1H/1I)



CIRCUIT NO.	PART NO.	DESCRIPTION
	Transistors	
Q6000-Q6004	2213284 or	2SC1740S-R or
Q6010-Q6014	2213285	2SC1740S-S
Q6020-Q6024	2213354,	2SA933S-R,
	2213355,	2SA933S-S,
	2212125 or	2SA1048-GR or
	2215995	KTA1267-GR
Q6030-Q6034	2203434 or	KTD2061-Y or
	2203010	2SC5171
Q6040-Q6044	2203424 or	KTB1369-Y or
	2203000	2SA1930
Q6050-Q6054	2203563,	* KTC5242-O
	2203562,	* KTC5242-R
	2202843,	* 2SC5242-O
	2202842,	* 2SC5242-R
	2201653,	* 2SC3856-O
	2201655 or	* 2SC3856-P
	2201654	* 2SC3856-Y
Q6060-Q6064	2203553,	* KTA1962-O
	2203552,	* KTA1962-R
	2202833,	* 2SA1962-O
	2202832,	* 2SA1962-R
	2201663,	* 2SA1492-O
	2201665 or	* 2SA1492-P
	2201664	* 2SA1492-Y
Q6070-Q6074	2210755,	2SC1775A-E,
	2210756,	2SC1775A-F,
	2211732,	2SC1845-F,
	2211733,	2SC1815-E,
	2215895 or	KTC3200-GR or
	2215896	KTC3200-BL
Q6600-Q6602	2215864,	KTC3199-GR,
Q6701,Q6702	2212115,	2SC2458-GR,
Q6901	2213284 or	2SC1740S-R or
	2213285	2SC1740S-S
Q6703	2211792,	2SA992-F,
	2211793,	2SA992-E,
	2215885 or	KTA1268-GR or
	2215886	KTA1268-BL
Q6704	2212125,	2SA1048-GR,
	2213354,	2SA933S-R,
	2215995 or	KTA1267-GR or
	2213355	2SA933S-S
	Diodes	
D6000-D6004	223163,	1SS133,
D6600-D6602	223205 or	1SS270A or
D6701,D6702	223222	WG713A
D6703,D6704	224470512	MTZJ5.1B
D6705,D6706	22380260,	RL1N4003
D6901,D6902	22380032 or	1SR139-100
	22380035	GP104003E
D6903,D6904	22380274	RS603M
D6906	223163,	1SS133,
	223205 or	1SS270A or
	223222	WG713A
	Coils	
L6000-L6004	231176SY	S-1.3C <P/A/WT/WR/GT>
C6020-C6024	354784709	47 μ F,50V,Elect.
C6030-C6034	374724734	0.047 μ F+/-5%,50V,Plastic
C6701,C6706	354721019	100 μ F,6.3V,Elect.
C6704	354780109	1 μ F,50V,Elect.
C6708	374722234	0.022 μ F+/-5%,50V,Plastic
C6901,C6902	3504313	12000 μ F,63V,Elect.

CIRCUIT NO.	PART NO.	DESCRIPTION
	Capacitors	
C6903	374722234	0.022 μ F+/-5%,50V,Plastic
C6904-C6907	374793344	0.33 μ F+/-5%,63V,Plastic
	Resistors	
R6040-R6044	5210258	N06HR1KBC,Trimming
R6070-R6074	443521814	180ohm+/-5%,1/2W,Metal oxide
R6080-R6084	453530224	2.2ohm+/-5%,1/2W,Metal
R6090-R6094	453530224	2.2ohm+/-5%,1/2W,Metal
R6100-R6104	4000201,	RF-5EGKR22,
	4000132 or	RGC55 0.22 or
	4500245	BPR55FK0.22,Metal plate
R6130-R6134	453630824	8.2ohm+/-5%,1/2W,Metal
R6850,R6851	443523914	390ohm+/-5%,1/2W,Metal oxide
R6904-R6907	453532294	0.22ohm+/-5%,1/2W,Metal
	Relays	
RL6600-RL6602	25065586	NRL-2P5A-DC24-142,
	25065563 or	NRL-2P5A-DC24-129 or
	25065517	NRL-2P5A-DC24-098
RL6604	25065574	NRL-1P5A-DC24-134
RL6901,RL6902	25065561,	NRL-1P10A-DC12-127,
	25065526,	NRL-1P10A-DC12-102,
	25065508 or	NRL-1P10A-DC12-093 or
	25065515	NRL-1P10A-DC12-096
	Switch	
S6901	25065581	NSS-22203
	Fuses	
F6901,F6902	252198	! 8A-UL, Fuse <D>
F6901,F6902	252099	! 8A-EAK, Fuse <P/WT/WR/A/GT>
	Fuseholders	
F6901A,F6901B	25052133	! NSCT-1P2031
F6902A,F6902B	25052133	! NSCT-1P2031
	Labels	
F6901C	29362800	T8AL250V,Fuse <P/A/WT/WR/GT>
	Sockets	
JL6803A,JL6804A	25051109	NSCT-5P896
JL6951A,JL6952A	25051109	NSCT-5P896
	Plugs	
P6000-P6004	25056009	NPLG-4P0959
P6011	25056017	NPLG-12P0967
P6080-P6084	25055038	NPLG-2P29
P6805	25055678	NPLG-8P634
P6931	25055805	NPLG-16P761
P931	25055701	NPLG-5P657
	Heatsink	
D6903B	27160483	RAD-152
	Screws	
D6903A,D6904A	838430107	3TTB+10S(BC), Self-tapping

REGULATOR CIRCUIT PC BOARD (NAPS-7078-1H/1I)

CIRCUIT NO.	PART NO.	DESCRIPTION
	Transistor	
Q9501	2211455 or	2SA1015-GR or
	2215975	KTA1266-GR
	Diodes	
D9501	22380022 or	RBV402 or
	22380285	RS403M
D9502-D9507	22380260,	RL1N4003,
	22380032 or	1SR139-100 or
	22380035	GP104003E
D9508	224473304	MTZJ33D
	Capacitors	
C9501-C9503	374721044	0.1 μ F+/-5%,50V,Plastic
C9505	354762229	2200 μ F,35V,Elect.
C9506	354761029S	1000 μ F,35V,Elect.
C9507	354762219	220 μ F,35V,Elect.

PRINTED CIRCUIT BOARD PARTS LIST

CIRCUIT NO.	PART NO.	DESCRIPTION	CIRCUIT NO.	PART NO.	DESCRIPTION
	Capacitors			Diodes	
C9508	354744729S	4700 μ F,16V,Elect.	D7001,D7002	223234R2 or	1SS352 or
C9510	354772219	220 μ F,63V,Elect.	D7004-D7006	223269R2	1SS355
	Resistors		D7003	224490820R2	UDZ8.2B
R6907	453532294	0.22ohm+/-5%,1/2W,Metal	D7007	224490510R2	UDZ5.1B
R9501,R9502	453530104	1ohm+/-5%,1/2W,Metal	D7008	224490270R2	UDZ2.7B
R9506	443522204	22ohm+/-5%,1/2W,Metal oxide	D7101	225290	SEL4110R
R9521	453530224	2.2ohm+/-5%,1/2W,Metal	D7103-D7106	225291D	SEL4910D-D <S/G>
	Fuses			225292D	SEL4310G-D
F9501	252075 or	 2.5A-SE-EAK or	L7001	231237M022R2	NCH-1471
	252241	 2.5A-SE-TL250V,Fuse <P/WT/WR/A/GT>		Coil	
	252160	 2.5A-UL/T-237, Fuse <D>	X7501	3010242	CST5.00MGW
	Fuseholders			Capacitors	
F9501A,F9501B	25052133	NSCT-1P2031	C7001	354722219	220 μ F,6.3V,Elect.
	Label		C7002,C7502	375524744	0.47 μ F+/-5%,50V,Plastic
F9501C	29361747	T2.5AL250V,Fuse <P/AWT/WR/GT>	C7007	354784709	47 μ F,50V,Elect.
	Sockets		C7016,C7517	353721019	100 μ F,6.3V,Elect.
JL6951B,JL6952B	25051109	NSCT-5P896	C7503	3000120	FMC0H104Z,Super
JL9501A	25051095	NSCT-11P882		Sockets	
			P412A	25051896 or	NSCT-14P1683 or
				25052535	NSCT-14P2432
			P7002A	25052055 or	NSCT-9P1842 or
				25051853	NSCT-9P1640
			P7003A	25051089	NSCT-5P876
			P7004A	25051087	NSCT-3P874
				Holder	
			Q7001A	27191074	(FL)
				Relay	
			RL7001	25065612	NRL-2P1A-DC4.5-157
				Switches	
			S7011-S7017	25035652	NPS-111-S604
			S7111,S7317	25035652	NPS-111-S604
			S7112-S7117	25035652	NPS-111-S604
			S7211-S7216	25035652	NPS-111-S604
			S7311	25065608	EC11B30C17
			S7312-S7315	25035652	NPS-111-S604
				VOLUME PC BOARD (NASW-7085-1H/1I/1J/1K)	
			CIRCUIT NO.	PART NO.	DESCRIPTION
			P7004B	25051087	NSCT-3P874,Socket
			S7001	25065575	EC16B2425,Rotary encoder
				HEDPHONE TERMINAL PC BOARD (NAETC-7086-1H/1I/1J/1K)	
			CIRCUIT NO.	PART NO.	DESCRIPTION
			P7003B	25051089	NSCT-5P876,Socket
			P7005	25045514	YKB26-5005,Headphone terminal
				TERMINAL PC BOARD (NAETC-7087-1H/1I/1J/1K)	
			CIRCUIT NO.	PART NO.	DESCRIPTION
				ICs	
			Q1001	22241297R2	BU1923F <P>
			Q1005	222780125	78M12HF
				Transistor	
			Q1002	2213145R2,	2SC2712-GR,
				2213143R2,	2SC2712-O,
				2213144R2,	2SC2712-Y,
				2213146R2,	2SC2712-BL,
				2216173R2,	KTC3875-O,
				2216174R2,	KTC3875-Y,
				2216175R2 or	KTC3875-GR or
				2216176R2	KTC3875-BL <P>
				Coil	
			L1001	231237K220R2	NCH-1477 <P>

CONSTANT VOLTAGE PC BOARD (NAPS-7079-1H/1I)

CIRCUIT NO.	PART NO.	DESCRIPTION
	ICs	
Q6402	222780155JRC	NJM78M15FA
Q6403	222790155JRC	NJM79M15FA
Q6405	222780054JRC	NJM7805FA
Q6406	222780055JRC	NJM78M05FA
	Capacitors	
C6403-C6406	394561007	10 μ F,35V,Elect.
C6409-C6412	394561007	10 μ F,35V,Elect.
	Resistors	
R6402	443621004	10ohm+/-5%,1W,Metal oxide
R6403	443523304	33ohm+/-5%,1/2W,Metal oxide
R6407,R6408	452730824	8.2ohm+/-5%,2W,Metal
R6410	452730684	6.8ohm+/-5%,2W,Metal
	Sockets	
JL6402A	25051088	NSCT-4P875
JL9501B	25051095	NSCT-11P882
P6411A	25051529	NSCT-18P1316
	Plug	
P6401	25055042	NPLG-3P32

THERMAL DETECTOR CIRCUIT PC BOARD (NAETC-7081-1H/1I)

CIRCUIT NO.	PART NO.	DESCRIPTION
R5380	4000151	PTH9M04BD222TS2F333,Thermister
R5381	4000149	PTH9M04BB222TS2F333,Thermister
JL6402B	25051088	NSCT-4P875,Socket

DISPLAY CIRCUIT PC BOARD (NADIS-7084-1H/1I/1J/1K)

CIRCUIT NO.	PART NO.	DESCRIPTION
	FL tube	
Q7001	212217	15-BT-74GNK
	Remote sensor	
U7001	241330	PIC-26043TE2
	IC	
Q7002	22241571R3	MPD780232GC-030-8BT
	Transistors	
Q7004,Q7006	2216190R2 or	KRC102S or
Q7101	2214470R2	RN1402
Q7103-Q7106	2216190R2 or	KRC102S or
	2214470R2	RN1402
Q7005	2214540R2 or	RN2403 or
Q7005	2216230R2	KRA103S

PRINTED CIRCUIT BOARD PARTS LIST

CIRCUIT NO. PART NO. DESCRIPTION			COMPOSITE VIDEO TERMINAL PC BOARD (NAVD-7096-1H/1I)		
X1001	Oscillator 3010203 or 3010345	AF6146CG or HQS-3H2-04332-20 <P>	Q261	IC 22240373	BA7625
C1003,C1007 C1012,C1016 C1014	Capacitors 354721019 354780339 354741009	100 μ F,6.3V,Elect. <P> 3.3 μ F,50V,Elect. 10 μ F,16V,Elect.	Q262,Q264 Q266	Transistors 2214375R2 or 2216185R2 2216031R2 or 2216032R2	2SA1162-GR or KTA1504-GR RN1444-A or RN1444-B
P1001A	Sockets 25052248, 25051859 or 25052061	NSCT-15P2145, NSCT-15P1646 or NSCT-15P1848	D261,D262	Diodes 223234R2 or 223269R2	1SS352 or 1SS355
P403A P409A,P702A	25051230 25051529	NSCT-5P1020 NSCT-18P1316	C261 C263 C264,C266 C265 C267-C269	Capacitors 354724719 354780229 354724719 354780109 354780229	470 μ F,6.3V,Elect. 2.2 μ F,50V,Elect. 470 μ F,6.3V,Elect. 1 μ F,50V,Elect. 2.2 μ F,50V,Elect.
P205A P311A	25055706 25055708	NPLG-10P662 NPLG-12P664	P262,P263 JL201A	Terminals 25045299 or 25045363 Socket 25051093	NPJ-3PDYE158 or NPJ-3PDYE208 NSCT-9P880
TONE CONTROL CIRCUIT PC BOARD (NAAF-7088-1H/1I/1J/1K)					
CIRCUIT NO.	PART NO.	DESCRIPTION	CIRCUIT NO.	PART NO.	DESCRIPTION
Q3501,Q3502	ICs 22241383R2 or 22240489R1NE	NJM4565M-D or MPC4570G2-T1(MST)	Q301,Q361 Q311	22241383R2 or 22240489R1NE 22240864	NJM4565M-D or MPC4570G2-T1(MST) TC9273N-004
C3501,C3502 C3505-C3508 C3509,C3510 C3511,C3512 C3513,C3514 C3515,C3516	Capacitors 354744709 354744709 374721534 354744709 374721534 354744709	47 μ F,16V,Elect. 47 μ F,16V,Elect. 0.015 μ F+/-5%,50V,Plastic 47 μ F,16V,Elect. 0.015 μ F+/-5%,50V,Plastic 47 μ F,16V,Elect.	C303,C304 C307,C308 C309,C310 C311,C312 C313,C314 C351,C352 C355,C356 C361-C364	354741009 354721019 374726824 374721824 354741009 354744719 354744709 393384707	10 μ F,16V,Elect. 100 μ F,6.3V,Elect. 6800pF+/-5%,50V,Plastic 1800pF+/-5%,50V,Plastic 10 μ F,16V,Elect. 470 μ F,16V,Elect. 47 μ F,16V,Elect. 47 μ F,50V,Elect.
R3509,R3510	Resistors 5104356	N14RLC100KWT20Z,Variable	P301-P303 P311B	25045571 or 25045300 Socket 25051237	NPJ-6PDRW386 or NPJ-6PDBL159 NSCT-12P1027
JL351A	Socket 25051093	NSCT-9P880			
S VIDEO TERMINAL PC BOARD(NAVD-7095-1H/1I)					
CIRCUIT NO.	PART NO.	DESCRIPTION	CIRCUIT NO.	PART NO.	DESCRIPTION
Q207,Q208	ICs 22240373	BA7625	Q207,Q208	22240373	BA7625
Q201,Q202	Transistors 2216031R2 or 2216032R2	RN1444-A or RN1444-B	Q201,Q202	2216031R2 or 2216032R2	RN1444-A or RN1444-B
Q203-Q206	2214375R2 or 2216185R2	2SA1162-GR or KTA1504-GR	Q203-Q206	2214375R2 or 2216185R2	2SA1162-GR or KTA1504-GR
Q209	2214530R2 or 2216220R2	RN2402 or KRA102S	Q209	2214530R2 or 2216220R2	RN2402 or KRA102S
D201,D202	Diodes 223234R2 or 223269R2	1SS352 or 1SS355	D201,D202	223234R2 or 223269R2	1SS352 or 1SS355
C204,C206 C208,C214 C210,C212 C217,C218	Capacitors 354780229 354724719 354780229 354724719	2.2 μ F,50V,Elect. 470 μ F,6.3V,Elect. 2.2 μ F,50V,Elect. 470 μ F,6.3V,Elect.	C204,C206 C208,C214 C210,C212 C217,C218	354780229 354724719 354780229 354724719	2.2 μ F,50V,Elect. 470 μ F,6.3V,Elect. 2.2 μ F,50V,Elect. 470 μ F,6.3V,Elect.
P201	Terminal 25045504 Socket	NPJ-1PDBL319	P201	25045504	NPJ-1PDBL319
JL201B P202,P203 P205B	25051093 25051568 25051235	NSCT-9P880 NSCT-12P1355 NSCT-10P1025	JL201B P202,P203 P205B	25051093 25051568 25051235	NSCT-9P880 NSCT-12P1355 NSCT-10P1025

CAUTION: Replacement for transistor of mark *, if necessary must be made from the same beta group (H β e) as the original type.

NOTE: THE COMPONENTS IDENTIFIED BY MARK  ARE CRITICAL FOR RISK OF FIRE AND ELECTRIC SHOCK. REPLACE ONLY WITH PART NUMBER SPECIFIED.

Note:

: Black model only
<G>: Golden model only
<S>: Silver model only
<D>: 120V model only
<P>: European model only
<WT>: Worldwide model only
<GT>: 220-230 V model only
<A>: Australian model only
<WR>: Chinese model only

PRINTED CIRCUIT BOARD PARTS LIST

DSP CIRCUIT PC BOARD (NADG-7066-1A/1B/1C/1D)

CIRCUIT NO.	PART NO.	DESCRIPTION
ICs		
Q101,Q102	22241383R2,	NJM4565M-D,
Q405-Q409	22240489R1NE or	MPC4570G2-T1(MST) or
Q802-Q804	22240581R2	NJM4565M
Q121	222740046R2TO	TC74HCU04F
Q151	22241520R2	AK4112AVF
Q401	22240943R2	TC9163AF
Q402	22240981R2	TC9162AF
Q403	22241444R2	TC9482F
Q701	22241518R9	CS493263-CL
Q702	22278025DR2NE	MPC2925T
Q703	22240935R2	TC7WU04FU
Q704	22278033DR2NE	MPC2933T
Q751	222740077R2TO	TC74HCT7007AF
Q752	22274541ER2TO	TC74VHC541FT
Q7701	22241570R3	MPD703033AGC-080-8EU
Q801	22241529R3	AK4527VQ
Photo couplers		
U121,U122	24120083 or 24120086	GP1FA550RZ or GP1FA551RZ
Transistors		
Q411-Q416	2215410R2	RN1441
Q417,Q418	2214530R2 or	RN2402 or
Q433,Q434	2216220R2	KRA102S
Q421-Q426	2215410R2	RN1441
Q428	2215410R2	RN1441
Q7702	2214490R2 or 2216210R2	RN1404 or KRC104S
Diodes		
D101-D108	223234R2 or	1SS352 or
D401,D402	223269R2	1SS355
D404,D405	223234R2 or 223269R2	1SS352 or 1SS355
D7701-D7703	223234R2 or	1SS352 or
D7706	223269R2	1SS355
D7705	224490620R2	UDZ6.2B
Oscillators		
X151	3010323R2	HC-49/U03C 12.288MHZ
X701	3010324R2	CSTCV12.2MTJ0C4
X7701	3010342R2	CSTCW2000MX01
Coils		
L121,L122	231237K470R2	NCH-1479
L152-L154	231237M022R2	NCH-1471
L701	231237K470R2	NCH-1479
L702,L703	231237M022R2	NCH-1471
L801,L802	231237K470R2	NCH-1479
L155,L156	230958R1	BK1608LM182-T
R121,R122	230958R1	BK1608LM182-T
Capacitors		
C106	356741009R2	10 μ F,16V,Elect.
C111,C112	356724709R2	47 μ F,6.3V,Elect.
C127,C132	356724709R2	47 μ F,6.3V,Elect.
C152,C158	356724709R2	47 μ F,6.3V,Elect.
C417-C422	356741009R2	10 μ F,16V,Elect.
C435-C440	356721019R2	100 μ F,6.3V,Elect.
C457-C462	356744709R2	47 μ F,16V,Elect.
C471-C476	356741009R2	10 μ F,16V,Elect.
C477,C478	374724744	0.47 μ F+/-5%,50V,Plastic
C706,C716	356724709R2	47 μ F,6.3V,Elect.
C719,C723	356724709R2	47 μ F,6.3V,Elect.
C7703	356724709R2	47 μ F,6.3V,Elect.
C7705,C7706	356780109R2	1 μ F,50V,Elect.
C7712	356721019R2	100 μ F,6.3V,Elect.
C806	356721019R2	100 μ F,6.3V,Elect.
C808	356742209R2	22 μ F,16V,Elect.
C809	356724709R2	47 μ F,6.3V,Elect.
C831-C836	356741009R2	10 μ F,16V,Elect.
C867-C870	356741019R2	100 μ F,16V,Elect.

CIRCUIT NO.	PART NO.	DESCRIPTION
P121	25045645	NPJ-2PDO450
P401	25045572	NPJ-6PDBRW387
P407	25045567	NPJ-1PDBL382
Sockets		
P412B	25052580R2	NSCT-14P2477
P404	2009990651UL	NSAS-20P0906
Plugs		
JL405B	25055630	NPLG-9P592
P403	25055704	NPLG-8P660
P409B	25055807	NPLG-18P763
P410B	25055708	NPLG-12P664
P411B	25055708	NPLG-12P664
P702B	25055807	NPLG-18P763
P7702	25055701	NPLG-5P657

POWER AMPLIFIER A PC BOARD (NAAF-7068-1A/1B/1C/1D/1E)

CIRCUIT NO.	PART NO.	DESCRIPTION
Transistors		
Q5000-Q5004	2210755,	2SC1775A-E,
Q5010-Q5014	2210756,	2SC1775A-F,
Q5020-Q5024	2211733 or 2215896	2SC1845-E or KTC3200-BL
Q5030-Q5034	2211353,	2SA949-O,
Q5040-Q5044	2211354,	2SA949-Y,
Q5050-Q5054	2215843 or 2215844	KTA1024-O or KTA1024-Y
Q5060-Q5064	2211633, 2211634, 2215854 or 2215853	2SC2229-O, 2SC2229-Y, KTC3206-Y or KTC3206-O
Diodes		
D5000-D5004	224470562	MTZJ5.6B
Capacitors		
C5000-C5004	393384707	47 μ F,50V,Elect.
C5010-C5014	374721515	150pF+/-10%,50V,Plastic
C5030-C5034	374721015	100pF+/-10%,50V,Plastic
Resistors		
C5040-C5044	393343317	330 μ F,16V,Elect.
C5050-C5054	354781009	10 μ F,50V,Elect.
C5070-C5074	354791009	10 μ F,100V,Elect.
C5080-C5084	354791009	10 μ F,100V,Elect.
C5090-C5094	354784709	47 μ F,50V,Elect.
C5120-C5124	393392207	22 μ F,100V,Elect.
C5130-C5134	393392207	22 μ F,100V,Elect.
C5401	354780109	1 μ F,50V,Elect.
Resistors		
R5130-R5134	443528214	820ohm+/-5%,1/2W,Metal oxide
R5140-R5144	443528214	820ohm+/-5%,1/2W,Metal oxide
R5150-R5154	443521034	10kohm+/-5%,1/2W,Metal oxide
R5160-R5164	443521024	1kohm+/-5%,1/2W,Metal oxide
R5170-R5174	443528214	820ohm+/-5%,1/2W,Metal oxide
R5180-R5184	443523304	33ohm+/-5%,1/2W,Metal oxide
R5190-R5194	443521014	100 ohm+/-5%,1/2W,Metal oxide
R5200-R5204	443521014	100 ohm+/-5%,1/2W,Metal oxide
R5230-R5234	443521004	10 ohm+/-5%,1/2W,Metal oxide
R5240-R5244	443521004	10 ohm+/-5%,1/2W,Metal oxide
R5280-R5284	443521034	10kohm+/-5%,1/2W,Metal oxide
Sockets		
P6000A-P6004A	25052287	NSCT-4P2184
P6011A	25052295	NSCT-12P2192
Plug		
P404A	25055154	NPLG-10P138

Note:
 : Black model only
 <G>: Golden model only
 <S>: Silver model only
 <D>: 120V model only
 <P>: European model only
 <WT>: Worldwide model only
 <GT>: 220-230 V model only
 <A>: Australian model only
 <WR>: Chinese model only

PRINTED CIRCUIT BOARD PARTS LIST

TERMINAL PC BOARD (NAETC-7069-1A/1B/1C/1D/1E)

CIRCUIT NO.	PART NO.	DESCRIPTION
Q6931	222780565JRC	NJM78M56FA
Q5303,Q5307	2215864, 2213284 or 2212115	KTC3199-GR, 2SC1740S-R or 2SC2458-GR
Q5308,Q5309	2215770, 2213510 or 2214350	KRA102M, DTA114ES or RN2202
D5306,D5307	223163, 223205 or 223222	1SS133, 1SS270A or WG713A
D6932,D6933	22380260, 22380032 or 22380035	RL1N4003, 1SR139-100 or GP104003E
C6931	354751029	1000 μ F, 25V, Elect.
C6933	354741009	10 μ F, 16V, Elect.
R6935	441721514	150 ohm \pm 5%, 2W, Metal oxide
P410A,P411A	25051237	NSCT-12P1027
P6931A	25051527	NSCT-16P1314
P7002B	25052242, 25050949, 25051313 or 25051853	NSCT-9P2139, NSCT-9P736, NSCT-9P1102 or NSCT-9P1640
P6411	25055807	NPLG-18P763
Q6931A	27160211	RAD-68
Q6931B	838430107	3TTB+10S(BC), Self-tapping

PRIMARY CIRCUIT PC BOARD (NAPS-7070-1A/1B/1C/1D/1E)

CIRCUIT NO.	PART NO.	DESCRIPTION
Q921	2215864, 2213285, 2213284 or 2212115	KTC3199-GR, 2SC1740S-S, 2SC1740S-R or 2SC2458-GR
D921-D924	22380260, 22380032 or 22380035	RL1N4003, 1SR139-100 or GP104003E
D925	223163, 223205 or 223222	1SS133, 1SS270A or WG713A
T902	2301381 2301382 2301383	\triangle NPT-1358D <D> \triangle NPT-1358P <P/A> \triangle NPT-1358DG <WT/WR>
C901	3500196S	\triangle RE275V-103M, .1S
C902	3300030	\triangle DE1307E472M-KH, IS
C922	354762219	220 μ F, 35V, Elect.
R901	431533355	\triangle 3.3Mohm, 1/2W, Solid <D>
R924	443522704	27ohm \pm 5%, 1/2W, Metal oxide
RL901	25065584, 25065516 or 25065588 25065561, 25065508, 25065515 or 25065526	\triangle NRL-1P10A-DC12-140, \triangle NRL-1P10A-DC12-097 or \triangle NRL-1P10A-DC12-143 <D/WT/WR> \triangle NRL-1P5A-DC12-127, \triangle NRL-1P10A-DC12-093, \triangle NRL-1P5A-DC12-096 or \triangle NRL-1P5A-DC12-102 <P/A>

CAUTION: Replacement for transistor of mark *, if necessary must be made from the same beta group (Hfe) as the original type.

CIRCUIT NO.	PART NO.	DESCRIPTION
P902	25051125 25051126 25052115 25052381	\triangle NSCT-4P912 <P/WT> \triangle NSCT-4P913 <D> \triangle NSCT-2P2013 <A> \triangle NSCT-2P2278 <WR>
F901	252198	\triangle 8A-UL, Fuse <D/WT/WR>
F902	252077	\triangle 4A-SE-EAK, Fuse <P/WT/WR/A>
F903	252075	\triangle 2.5A-SE-EAK, Fuse <P/A>
F901A,F901B	25052133	\triangle NSCT-1P2031 <D/WT/WR>
F902A,F902B	25052133	\triangle NSCT-1P2031 <P/WT/AWR>
F903A,F903B	25052133	\triangle NSCT-1P2031 <P>
S902	25065437	\triangle NSS-22157P <WT/WR>
F901D	29360842	Fuse <D/WT/WR>
F902C	29361732A	T4AL250V <P/WT/AWR>
P931A	25051230	NSCT-5P1020
P901A	25055675 or 25056028	NPLG-2P631 or NPLG-2P0978

SPEAKER TERMINAL A PC BOARD (NAETC-7071-1A/1B/1C/1D/1E)

CIRCUIT NO.	PART NO.	DESCRIPTION
C6840,C6841	374721024	1000pF \pm 5%, 50V, Plastic
C6844	374721024	1000pF \pm 5%, 50V, Plastic
P6803	25060297	NTM-6PDMN228
JL6803B,JL6804	25050269	NSCT-5P97

SPEAKER TERMINAL B PC BOARD (NAETC-7072-1A/1B/1C/1D/1E)

CIRCUIT NO.	PART NO.	DESCRIPTION
C6842,C6843	374721024	1000pF \pm 5%, 50V, Plastic <P/WT/AWR>
C6845,C6846	374721024	1000pF \pm 5%, 50V, Plastic
P6802	25060296	NTM-8PDMN227
P6805A	25051127	NSCT-8P914

POWER SWITCH PC BOARD (NASW-7074-1A/1B/1C/1D/1E)

CIRCUIT NO.	PART NO.	DESCRIPTION
S906	25035550	\triangle NPS-111-L512P, Power switch

POWER AMPLIFIER B PC BOARD (NAAF-7077-1A/1B/1D)

CIRCUIT NO.	PART NO.	DESCRIPTION
Q6000-Q6004	2213284 or	2SC1740S-R or
Q6010-Q6014	2213285	2SC1740S-S
Q6020-Q6024	2213354, 2213355, 2212125 or 2215995	2SA933S-R, 2SA933S-S, 2SA1048-GR or KTA1267-GR
Q6030-Q6034	2203434 or 2203010	KTD2061-Y or 2SC5171
Q6040-Q6044	2203424 or 2203000	KTB1369-Y or 2SA1930
Q6050-Q6054	2202823 or 2202822	* 2SC5200-O or * 2SC5200-R
Q6060-Q6064	2202813 or 2202812	* 2SA1943-O or * 2SA1943-R

NOTE: THE COMPONENTS IDENTIFIED BY MARK \triangle ARE CRITICAL FOR RISK OF FIRE AND ELECTRIC SHOCK. REPLACE ONLY WITH PART NUMBER SPECIFIED.

PRINTED CIRCUIT BOARD PARTS LIST

CIRCUIT NO.	PART NO.	DESCRIPTION	CIRCUIT NO.	PART NO.	DESCRIPTION
Q6070-Q6074	Transistors 2214984 or 2214985	2SC2631-R or 2SC2631-S	P6801	Terminal 25045572	NPJ-6PDBRW387
Q6600-Q6602	2215864,	KTC3199-GR,	JL6803A,JL6804	Sockets 25051109	NSCT-5P896
Q6701,Q6702	2212115,	2SC2458-GR,	JL6951A,JL6952	25051109	NSCT-5P896
Q6901	2213284 or 2213285	2SC1740S-R or 2SC1740S-S		Plugs 25056009	NPLG-4P0959
Q6703	2211792, 2211793,	2SA992-F, 2SA992-E,	P6000-P6004	25056017	NPLG-12P0967
	2215885 or 2215886	KTA1268-GR or KTA1268-BL	P6080-P6084	25055038	NPLG-2P29
Q6704	2212125, 2213354,	2SA1048-GR, 2SA933S-R,	P6805	25055678	NPLG-8P634
	2215995 or 2213355	KTA1267-GR or 2SA933S-S	P6931	25055805	NPLG-16P761
	Diodes 223163,	1SS133,	P931	25055701	NPLG-5P657
D6000-D6004	223205 or 223222	1SS270A or WG713A	D6903B	Heatsink 27160483	RAD-152
D6701,D6702	224470512	MTZJ5.1B		Screws 838430107	3TTB+10S(BC), Self-tapping
D6703,D6704	22380260,	RL1N4003	REGULATOR CIRCUIT PC BOARD (NAPS-7078-1A/1B/1D)		
D6705,D6706	22380032 or 22380035	1SR139-100 GP104003E	CIRCUIT NO.	PART NO.	DESCRIPTION
D6901,D6902	22380273	RS804M	Q9501	2211455 or 2215975	2SA1015-GR or KTA1266-GR
D6903,D6904	223163,	1SS133,		Diodes 22380022 or 22380285	RBV402 or RS403M
D6906	223205 or 223222	1SS270A or WG713A	D9501	22380260, 22380032 or 22380035	RL1N4003, 1SR139-100 or GP104003E
L6000-L6004	Coils 231176SY	S-1.3C <P/A/WT/WR>	D9502-D9507	224473304	MTZJ33D
C6020-C6024	Capacitors 354784709	47 μ F,50V,Elect.	D9508	Capacitors 374721044	0.1 μ F+/-5%,50V,Plastic
C6030-C6034	374724734	0.047 μ F+/-5%,50V,Plastic	C9501-C9503	354762229	2200 μ F,35V,Elect.
C6701,C6706	354721019	100 μ F,6.3V,Elect.	C9505	354761029S	1000 μ F,35V,Elect.
C6704	354780109	1 μ F,50V,Elect.	C9507	354762219	220 μ F,35V,Elect.
C6708	374722234	0.022 μ F+/-5%,50V,Plastic	C9508	354744729S	4700 μ F,16V,Elect.
C6901,C6902	3504373	15000 μ F,71V,Elect.	C9510	354772219	220 μ F,63V,Elect.
C6903	374722234	0.022 μ F+/-5%,50V,Plastic		Resistors 453532294	0.22ohm+/-5%,1/2W,Metal
C6904-C6907	374793344	0.33 μ F+/-5%,63V,Plastic	R6907	453530104	1ohm+/-5%,1/2W,Metal
R6040-R6044	5210258	N06HR1KBC,Trimming	R9501,R9502	443522204	22ohm+/-5%,1/2W,Metal oxide
R6070-R6074	443521814	180ohm+/-5%,1/2W,Metal oxide	R9506	453530224	2.2ohm+/-5%,1/2W,Metal
R6080-R6084	453530224	2.2ohm+/-5%,1/2W,Metal	R9521	453530224	2.2ohm+/-5%,1/2W,Metal
R6090-R6094	453530224	2.2ohm+/-5%,1/2W,Metal		Fuses 252075	! 2.5A-SE-EAK,Fuse
R6100-R6104	4000201, 4000132 or 4500245	RF-5EGKR22, RGC55 0.22 or BPR55FK0.22,Metal plate	F9501	252160	! 2.5A-UL/T-237, Fuse <D>
R6130-R6134	453630824	8.2ohm+/-5%,1/2W,Metal	F9501	Fuseholders 25052133	! NSCT-1P2031
R6850,R6851	443523914	390ohm+/-5%,1/2W,Metal oxide	F9501B	Label 29361747	T.25AL250V,Fuse <P/A/WT/WR>
R6904-R6907	453532294	0.22ohm+/-5%,1/2W,Metal	F9501C	Sockets 25051109	NSCT-5P896
RL6600-RL6602	25065563, 25065517 or 25065586	NRL-2P5A-DC24-129, NRL-2P5A-DC24-098 or NRL-2P5A-DC24-142	JL9501A	25051095	NSCT-11P882
RL6604	25065574	NRL-1P5A-DC24-134	CONSTANT VOLTAGE PC BOARD (NAPS-7079-1A/1B/1D)		
RL6901,RL6902	25065584, 25065516 or 25065588	NRL-1P10A-DC12-140, NRL-1P10A-DC12-097 or NRL-1P10A-DC12-143	CIRCUIT NO.	PART NO.	DESCRIPTION
S6901	Switch 25065581	△ NSS-22203	Q6402	222780155JRC	NJM78M15FA
F6901A,F6901B	Fuseholders 25052133	△ 10A-UL, Fuse <D>	Q6403	222790155JRC	NJM79M15FA
F6902A,F6902B	25052133	△ 10A-EAK, Fuse <P/WT/WR/A>	Q6405	222780054JRC	NJM7805FA
F6901,F6902	Fuses 252199	△ 10A-UL, Fuse <D>	Q6406	222780055JRC	NJM78M05FA
F6901,F6902	252100	△ 10A-EAK, Fuse <P/WT/WR/A>		Capacitors 394561007	10 μ F,35V,Elect.
F6901C	29362241	△ 10A/125V,Fuse <D>	C6403-C6406	394561007	10 μ F,35V,Elect.
F6901C	29362801	△ T10AL250V,Fuse <P/A/WT/WR>		Resistors 443621004	10ohm+/-5%,1W,Metal oxide
			R6403	443523304	33ohm+/-5%,1/2W,Metal oxide
			R6407,R6408	452730824	8.2ohm+/-5%,2W,Metal
			R6410	452730684	6.8ohm+/-5%,2W,Metal

NOTE: THE COMPONENTS IDENTIFIED BY MARK △ ARE CRITICAL FOR RISK OF FIRE AND ELECTRIC SHOCK. REPLACE ONLY WITH PART NUMBER SPECIFIED.

PRINTED CIRCUIT BOARD PARTS LIST

CIRCUIT NO.	PART NO.	DESCRIPTION	VOLUME PC BOARD (NASW-7085-1A/1B/1C/1D)		
CIRCUIT NO.	PART NO.	DESCRIPTION	CIRCUIT NO.	PART NO.	DESCRIPTION
JL6402A	25051088	NSCT-4P875	P7004B	25051087	NSCT-3P874,Socket
JL9501B	25051095	NSCT-11P882	S7001	25065575	EC16B2425,Rotary encoder
P6411A	25051529	NSCT-18P1316	HEDPHONE TERMINAL PC BOARD (NAETC-7086-1A/1B/1C/1D)		
Plug			CIRCUIT NO.	PART NO.	DESCRIPTION
P6401	25055042	NPLG-3P32	P7003B	25051089	NSCT-5P876,Socket
THERMAL DETECTOR CIRCUIT PC BOARD (NAETC-7081-1A/1B/1D)			P7005	25045514	YKB26-5005,Headphone terminal
CIRCUIT NO.	PART NO.	DESCRIPTION	TERMINAL PC BOARD (NAETC-7087-1A/1B/1C/1D)		
R5380	4000151	PTH9M04BD222TS2F333,Thermister	CIRCUIT NO.	PART NO.	DESCRIPTION
R5381	4000149	PTH9M04BB222TS2F333,Thermister	ICs		
JL6402B	25051088	NSCT-4P875,Socket	Q1001	22241297R2	BU1923F <P>
DISPLAY CIRCUIT PC BOARD (NADIS-7084-1A/1B/1C/1D)			Q1005	222780125	78M12HF
CIRCUIT NO.	PART NO.	DESCRIPTION	Transistor		
FL tube			Q1002	2213145R2,	2SC2712-GR,
Q7001	212216	16-BT-96GNK		2213143R2,	2SC2712-O,
Remote sensor				2213144R2,	2SC2712-Y,
U7001	241330	PIC-26043TE2		2213146R2,	2SC2712-BL,
IC				2216173R2,	KTC3875-O,
Q7002	22241571R3	MPD780232GC-030-8BT		2216174R2,	KTC3875-Y,
Transistors				2216175R2 or	KTC3875-GR or
Q7003	2213145R2,	2SC2712-GR,		2216176R2	KTC3875-BL
	2213143R2,	2SC2712-O,	L1001	231237K220R2	NCH-1477 <P>
	2213144R2,	2SC2712-Y,	Coil		
	2213146R2,	2SC2712-BL,	X1001	3010203 or	AF6146CG or
	2216173R2,	KTC3875-O,		3010345	HQS-3H2-04332-20 <P>
	2216174R2,	KTC3875-Y,	Capacitors		
	2216175R2 or	KTC3875-GR or	C1003,C1007	354721019	100 μ F,6.3V,Elect. <P>
	2216176R2	KTC3875-BL	C1012,C1016	354780339	3.3 μ F,50V,Elect.
Q7004,Q7006	2216190R2 or	KRC102S or	C1014	354741009	10 μ F,16V,Elect.
Q7101-Q7106	2214470R2	RN1402	Sockets		
Q7005	2214540R2 or	RN2403 or	P1001A	25052248,	NSCT-15P2145,
Q7005	2216230R2	KRA103S		25051859 or	NSCT-15P1646 or
Diodes				25052061	NSCT-15P1848
D7001,D7002	223234R2 or	1SS352 or	P403A	25051233	NSCT-8P1023
D7004-D7006	223269R2	1SS355	P409A,P702A	25051529	NSCT-18P1316
D7003	224490820R2	UDZ8.2B	Plugs		
D7007	224490510R2	UDZ5.1B	P205A	25055712	NPLG-20P668
D7008	224490270R2	UDZ2.7B	P311A	25055805	NPLG-16P761
D7101	225290	SEL4110R	TONE CONTROL CIRCUIT PC BOARD (NAAF-7088-1A/1B/1C/1D)		
D7102	225291D	SEL4910D-D	CIRCUIT NO.	PART NO.	DESCRIPTION
D7103-D7106	225291D	SEL4910D-D <S/G>	ICs		
D7103-D7106	225292D	SEL4310G-D 	Q3501,Q3502	22241383R2 or	NJM4565M-D or
Coil				22240489R1NE	MPC4570G2-T1(MST)
L7001	231237M022R2	NCH-1471	Capacitors		
Oscillator			C3501,C3502	354744709	47 μ F,16V,Elect.
X7501	3010242	CST5.00MGW	C3505-C3508	354744709	47 μ F,16V,Elect.
Capacitors			C3509,C3510	374721534	0.015 μ F+/-5%,50V,Plastic
C7001	354722219	220 μ F,6.3V,Elect.	C3511,C3512	354744709	47 μ F,16V,Elect.
C7002,C7502	375524744	0.47 μ F+/-5%,50V,Plastic	C3513,C3514	374721534	0.015 μ F+/-5%,50V,Plastic
C7007	354784709	47 μ F,50V,Elect.	C3515,C3516	354744709	47 μ F,16V,Elect.
C7016,C7517	353721019	100 μ F,6.3V,Elect.	Resistors		
C7503	3000120	FMC0H104Z,Super	R3509,R3510	5104356	N14RLC100KWT20Z,Variable
Sockets			Socket		
P412A	25051896 or	NSCT-14P1683 or	JL351A	25051093	NSCT-9P880
	25052535	NSCT-14P2432			
P7002A	25052055 or	NSCT-9P1842 or			
	25051853	NSCT-9P1640			
P7003A	25051089	NSCT-5P876			
P7004A	25051087	NSCT-3P874			
Relay					
RL7001	25065612	NRL-2P1A-DC4.5-157			
Switches					
S7011-S7017	25035652	NPS-111-S604			
S7111-S7117	25035652	NPS-111-S604			
S7211-S7216	25035652	NPS-111-S604			
S7311	25065608	EC11B30C17			
S7312-S7317	25035652	NPS-111-S604			
Holder					
Q7001A	27191074	(FL)			

PRINTED CIRCUIT BOARD PARTS LIST

S VIDEO TERMINAL PC BOARD (NAVD-7090-1A/1B)

CIRCUIT NO.	PART NO.	DESCRIPTION
		ICs
Q212,Q213	22240373	BA7625
Q224	22241221R2	TC9164AF
		Transistors
Q201	2216031R2 or	RN1444-A or
Q202-Q204	2216032R2	RN1444-B
Q205-Q210	2214375R2 or	2SA1162-GR or
Q215	2216185R2	KTA1504-GR
Q216-Q219	2216031R2 or	RN1444-A or
Q222,Q223	2216032R2	RN1444-B
Q220	2214530R2 or	RN2402 or
	2216220R2	KRA102S
		Diodes
D201-D204	223234R2 or	1SS352 or
D201-D204	223269R2	1SS355
		Coils
L201,L203	231237K022R2	NCH-1471
L202,L204	231292J056R2	NCH-1572
		Capacitors
C206,C208	354780229	2.2 μ F,50V,Elect.
C209,C215	354780229	2.2 μ F,50V,Elect.
C211,C213	354724719	470 μ F,6.3V,Elect.
C217,C221	354780229	2.2 μ F,50V,Elect.
C219	354724719	470 μ F,6.3V,Elect.
C222	354784799	0.47 μ F,50V,Elect.
C225-C227	354724719	470 μ F,6.3V,Elect.
		Terminal
P204	25045504	NPJ-1PDBL319
		Sockets
P201	25051748	NSCT-8P1535
P202,P203	25051568	NSCT-12P1355
P205B	25051241	NSCT-20P1031
P206B	25051834	NSCT-27P1621
		Plug
JL204B	25055627	NPLG-6P589

COMPOSITE VIDEO PC BOARD (NAVD-7091-1A/1B)

CIRCUIT NO.	PART NO.	DESCRIPTION
		ICs
Q2001	22240373	BA7625
Q2004	22241579	NJM2267D
Q2005	22241037	LC74761-9189
		Transistors
Q2002,Q2003	2216031R2 or	RN1444-A or
Q2013-Q2015	2216032R2	RN1444-B
Q2006-Q2008	2214375R2 or	2SA1162-GR or
Q2010,Q2012	2216185R2	KTA1504-GR
Q2016	2213145R2 or	2SC2712-GR or
	2216175R2	KTC3875-GR
Q2017,Q2018	2216031R2 or	RN1444-A or
	2216032R2	RN1444-B
		Diodes
D2001-D2003	223234R2 or	1SS352 or
	223269R2	1SS355
		Coils
L2001	231237K022R2	NCH-1471
L2002	231292J056R2	NCH-1572
		Capacitors
C2001	354724719	470 μ F,6.3V,Elect.
C2010-C2012	354724719	470 μ F,6.3V,Elect.
C2013,C2029	354780109	1 μ F,50V,Elect.
C2016,c2018	354721019	100 μ F,6.3V,Elect.
C2020,C2055	354744709	47 μ F,16V,Elect.
C2021,C2025	375524744	0.47 μ F+/-5%,50V,Plastic
C2022,C2042	354721019	100 μ F,6.3V,Elect.
C2023	354783399	0.33 μ F,50V,Elect.
C2027	374721224	1200pF+/-5%,50V,Plastic
C2028,C2033	354780229	2.2 μ F,50V,Elect.

CIRCUIT NO.	PART NO.	DESCRIPTION
		Capacitors
C2032	374726824	6800pF+/-5%,50V,Plastic
C2034,C2036	354724719	470 μ F,6.3V,Elect.
C2035	354780229	2.2 μ F,50V,Elect.
C2037,C2038	354780229	2.2 μ F,50V,Elect.
C2039	354724719	470 μ F,6.3V,Elect.
C2040	354784799	0.47 μ F,50V,Elect.
C2041	374722234	0.022 μ F+/-5%,50V,Plastic
C2045	354780109	1 μ F,50V,Elect.
C2046,C2047	354724719	470 μ F,6.3V,Elect.
		Terminals
P2001	25045569	NPJ-2PDYE384
P2002,P2003	25045299	NPJ-3PDYE158
P2004	25045504	NPJ-1PDBL319
		Socket
P206A	25051834	NSCT-27P1621
		Oscillators
X2001	3010167 or	XTL-14.32M or
	3010347	HQS-HC49U-14318-11
X2002	3010238 or	XTL-17.73M or
	3010348	HQS-HC49U-17734-11
		<P/A/WT/WR>

COMPONENT VIDEO TERMINAL PC BOARD (NAVD-7092-1A/1B)

CIRCUIT NO.	PART NO.	DESCRIPTION
		Transistor
Q2101	2214460R2 or	RN1401 or
Q2101	2216330R2	KRC101S
		Diodes
D2101,D2102	223234R2 or	1SS352 or
	223269R2	1SS355
		Capacitor
C2113	354780109	1 μ F,50V,Elect.
		Terminals
P2101-P2103	25045629	NPJ-3PDGLR436
		Relays
RL2101,RL2102	25065610	NRL-2P1A-DC4.5-156
		Socket
JL204A	25051090	NSCT-6P877

INPUT TERMINAL PC BOARD (NAAF-7093-1A/1B)

CIRCUIT NO.	PART NO.	DESCRIPTION
		ICs
Q301,Q361	22241383R2 or	NJM4565M-D or
Q371	22240489R1NE	MPC4570G2-T1(MST)
Q311	22241221R2	TC9164AF
Q312	22240829	TC9274N-008
		Transistors
Q373,Q374	2215410R2	RN1441
		Capacitors
C303,C304	354741009	10 μ F,16V,Elect.
C307,C308	354721019	100 μ F,6.3V,Elect.
C309,C310	374726824	6800pF+/-5%,50V,Plastic
C311,C312	374721824	1800pF+/-5%,50V,Plastic
C313,C314	354741009	10 μ F,16V,Elect.
C351	354744719	470 μ F,16V,Elect.
C352	354741029S	1000 μ F,16V,Elect.
C355,C356	354744709	47 μ F,16V,Elect.
C361,C362	393384707	47 μ F,50V,Elect.
C371,C372	393380227	2.2 μ F,50V,Elect.
C373,C374	393384707	47 μ F,50V,Elect.
C377,C378	374721024	1000pF+/-5%,50V,Plastic
		Terminals
P301-P303	25045571 or	NPJ-6PDRW386 or
	25045300	NPJ-6PDBL159
P304	25045575 or	NPJ-4PDRW389 or
	25045303	NPJ-4PDBL162
		Socket
P311B	25051527	NSCT-16P1314

WIRING VIEW

The bracket < > shows the page of schematic diagram.

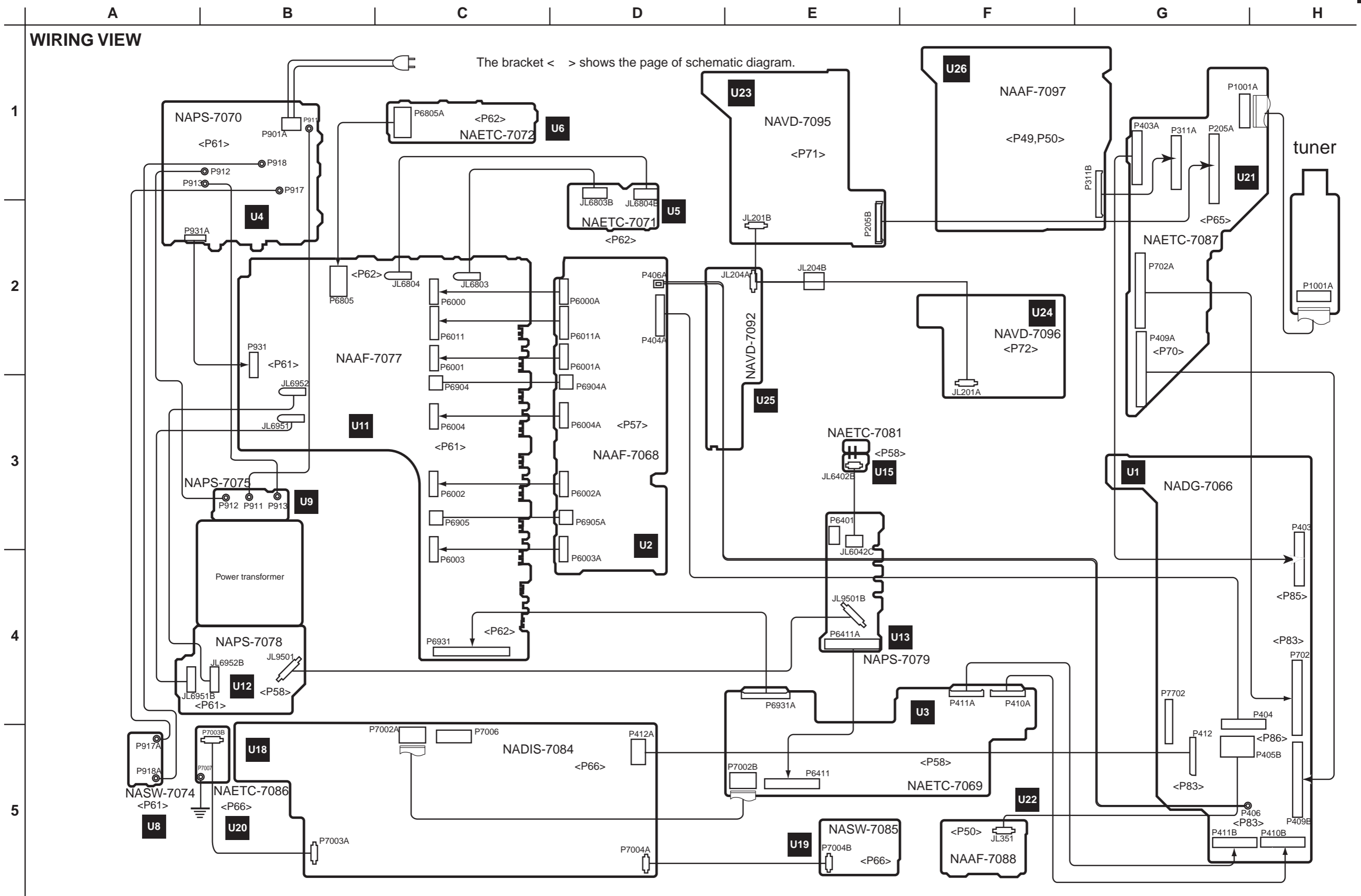

BLOCK DIAGRAM

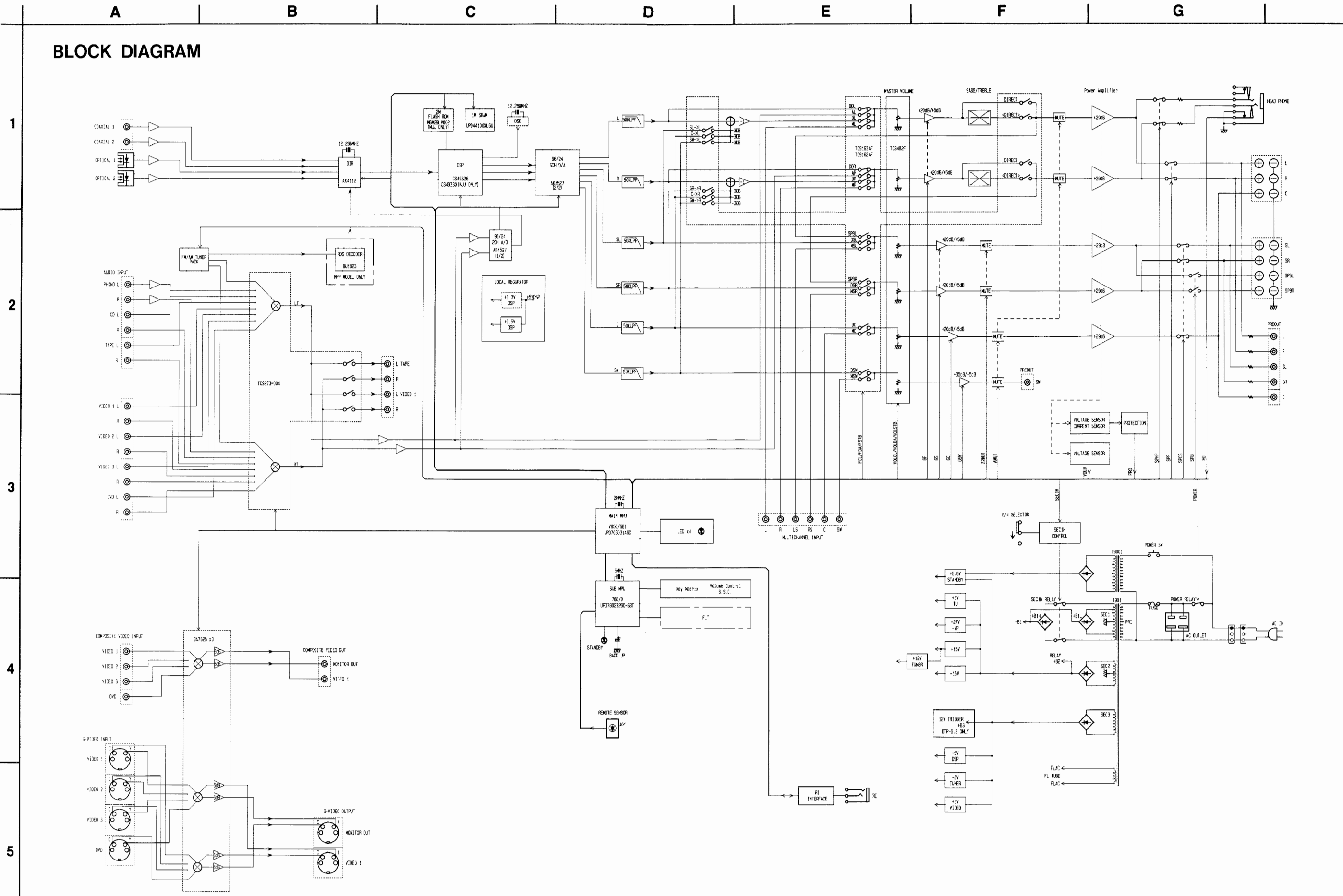

WIRING VIEW

The bracket < > shows the page of schematic diagram.

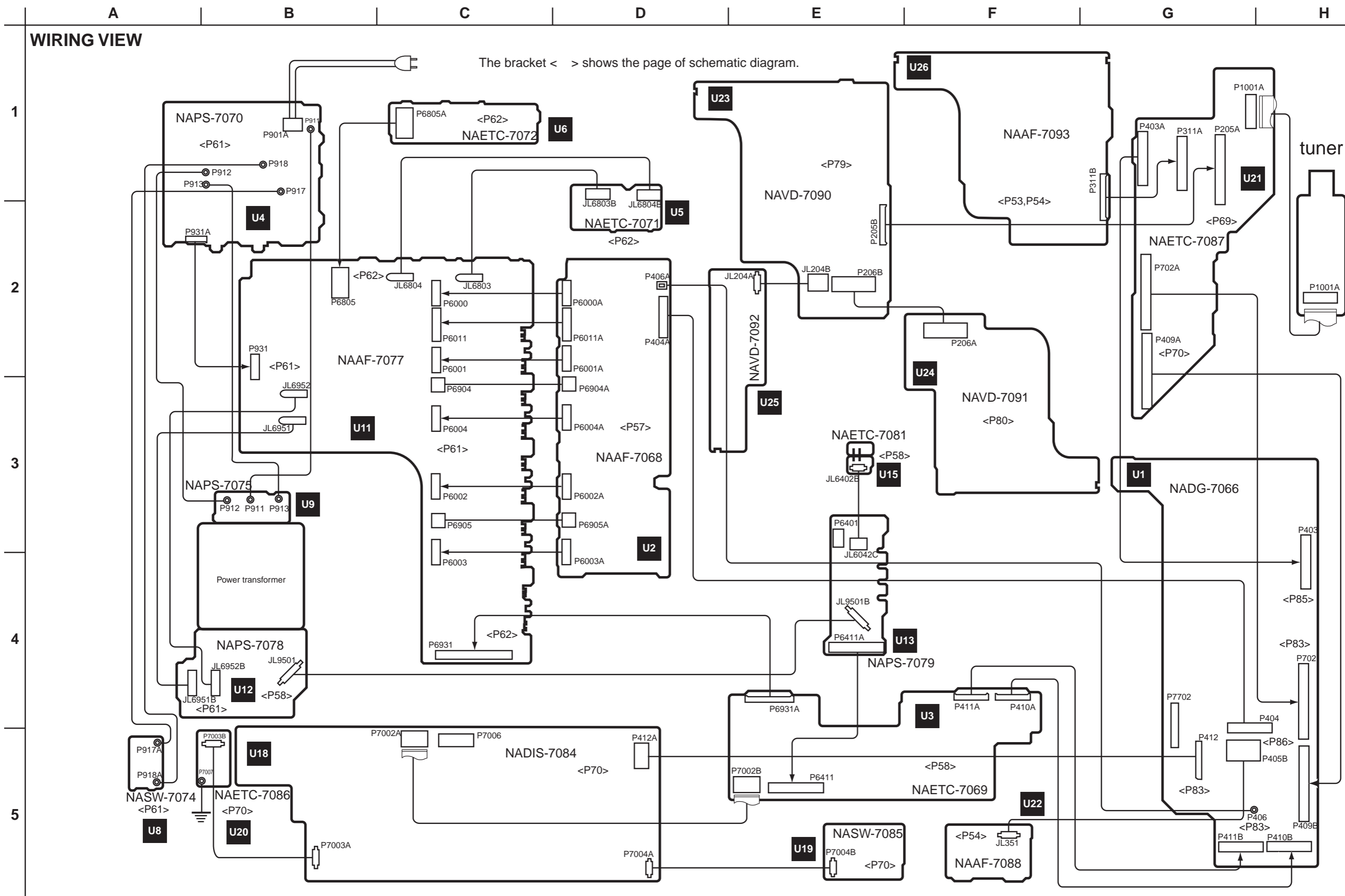

BLOCK DIAGRAM

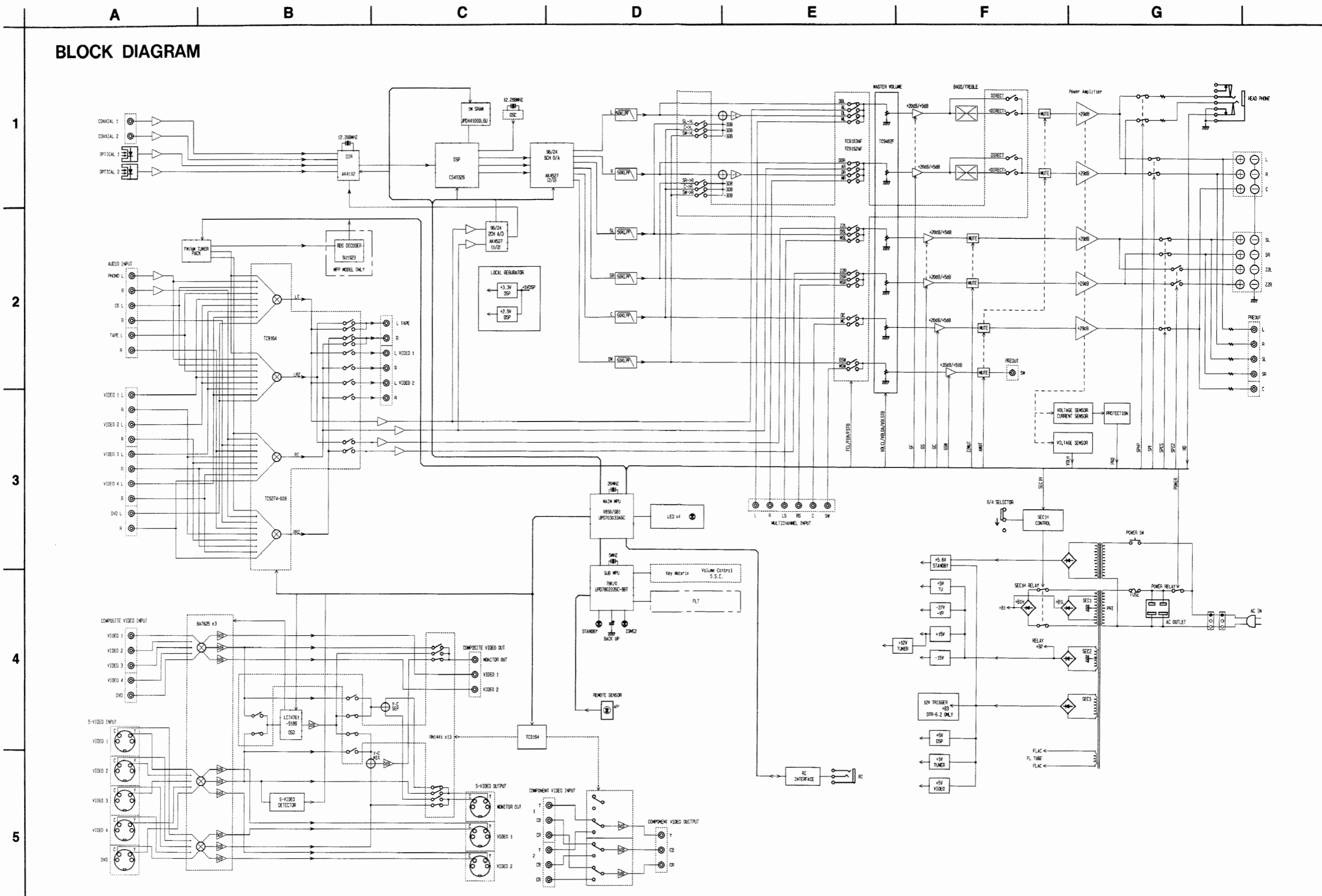

1

2

3

4

5

PC BOARD VIEW FROM SOLDERING SIDE

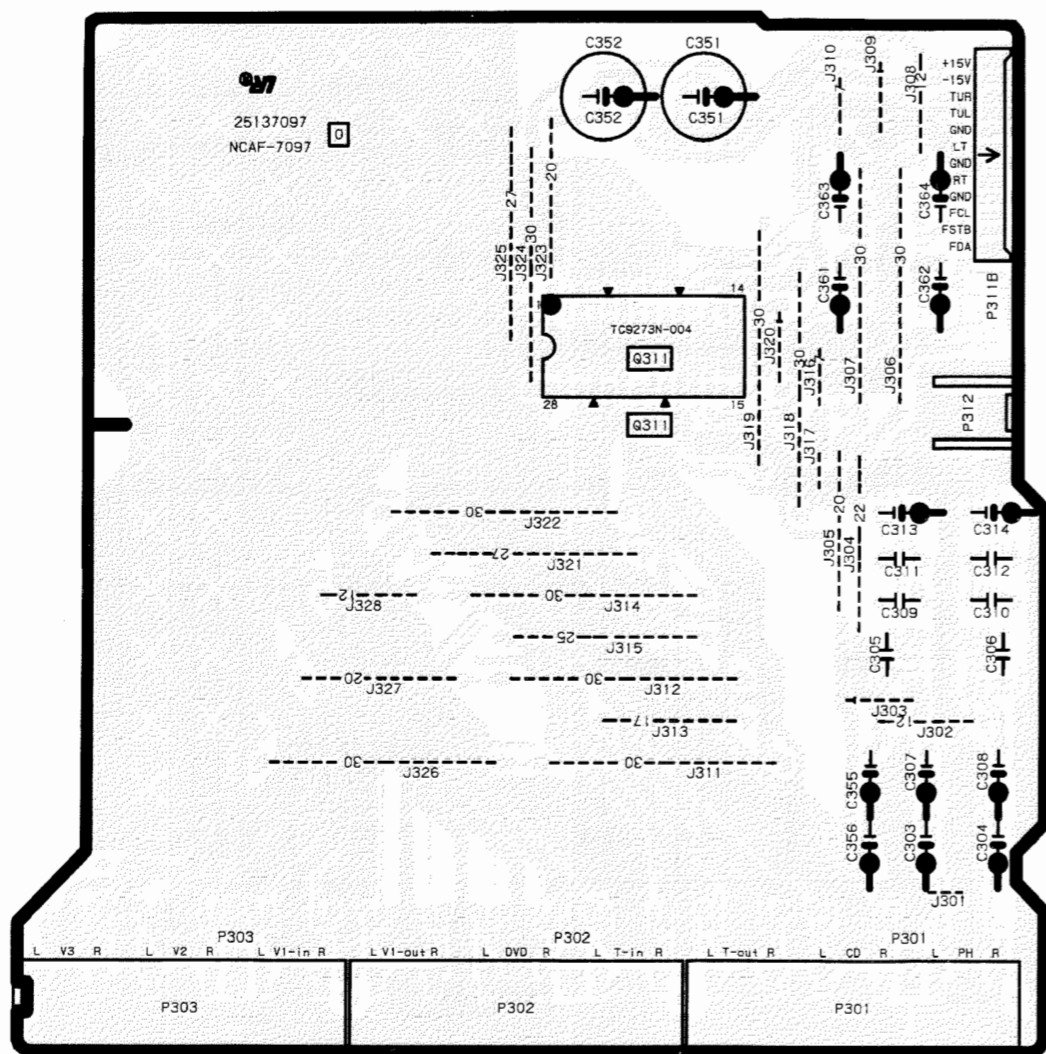

COMPONENT SIDE

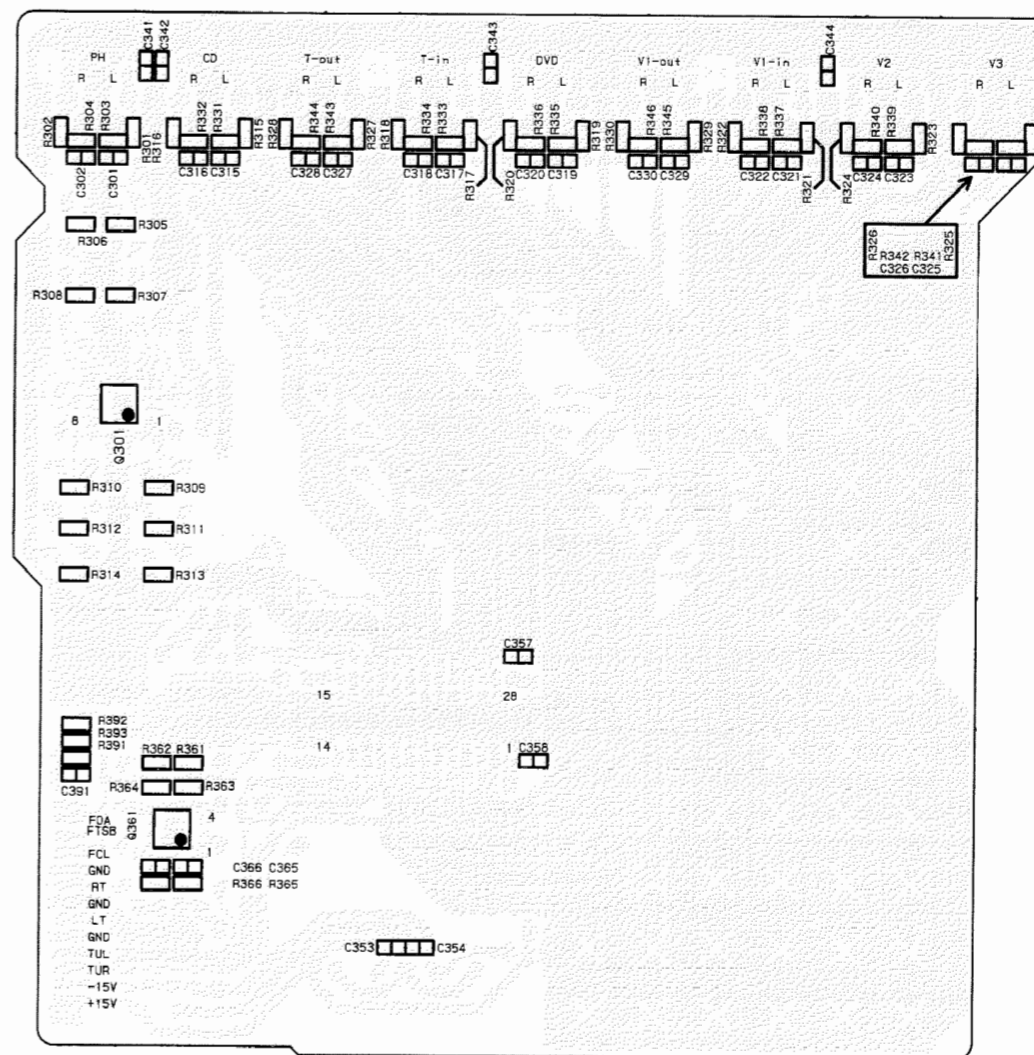

SOLDERING SIDE

INPUT TERMINAL PC BOARD

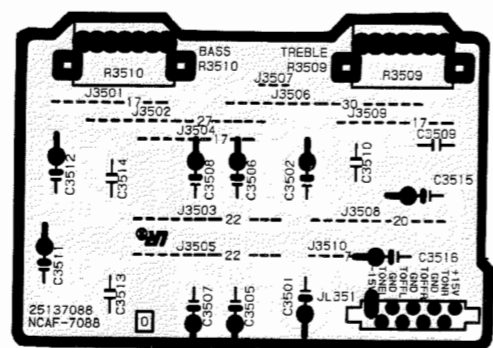

COMPONENT SIDE

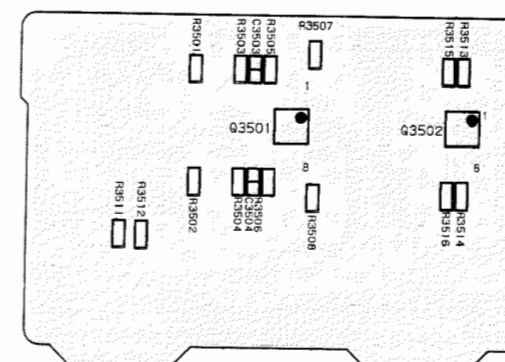

SOLDERING SIDE

TONE CONTROL CIRCUIT PC BOARD

**SCHEMATIC DIAGRAM
INPUT SECTION**

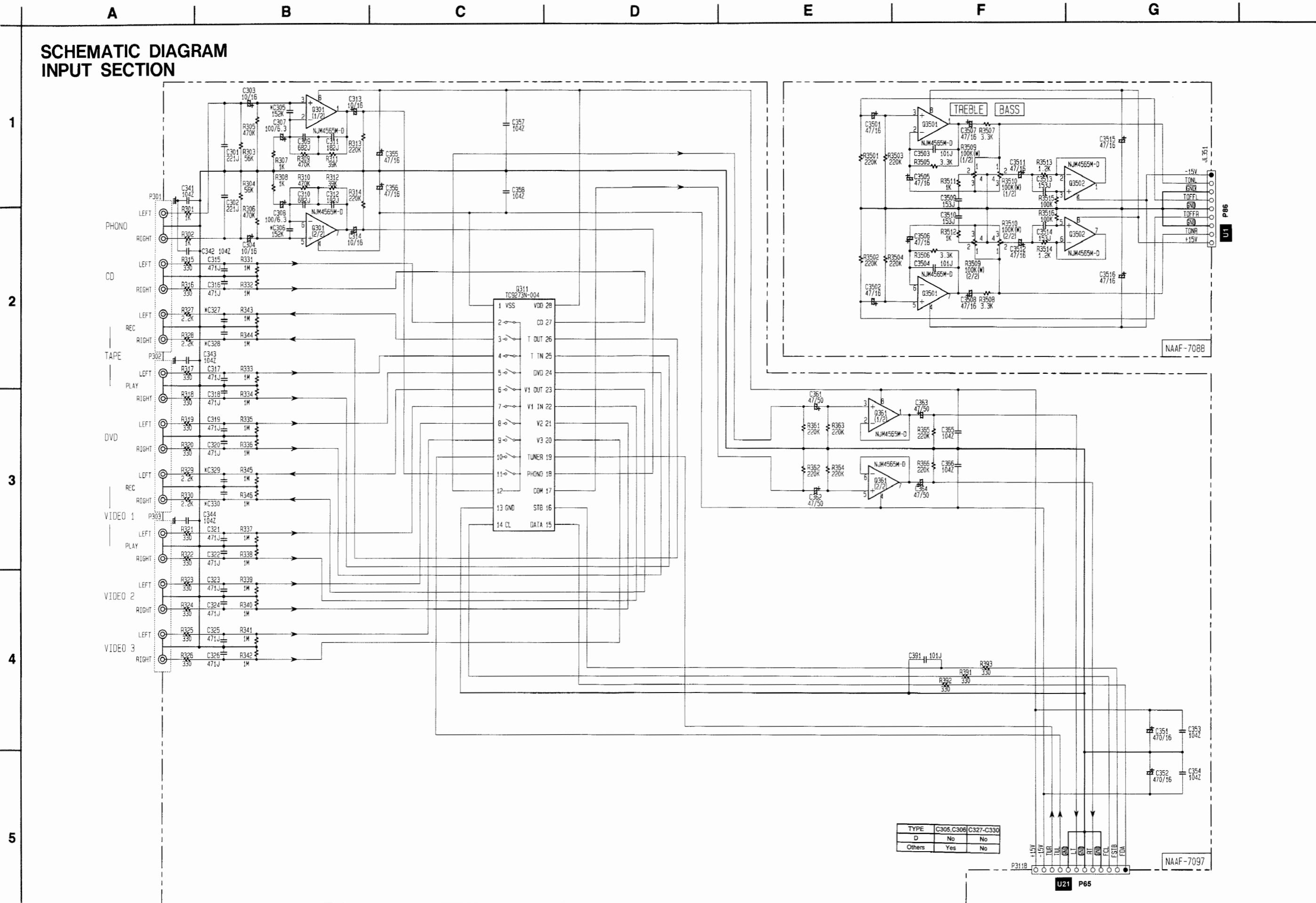

TYPE	C305, C306	C327-C330
D	No	No
Others	Yes	No

PC BOARD VIEW FROM SOLDERING SIDE

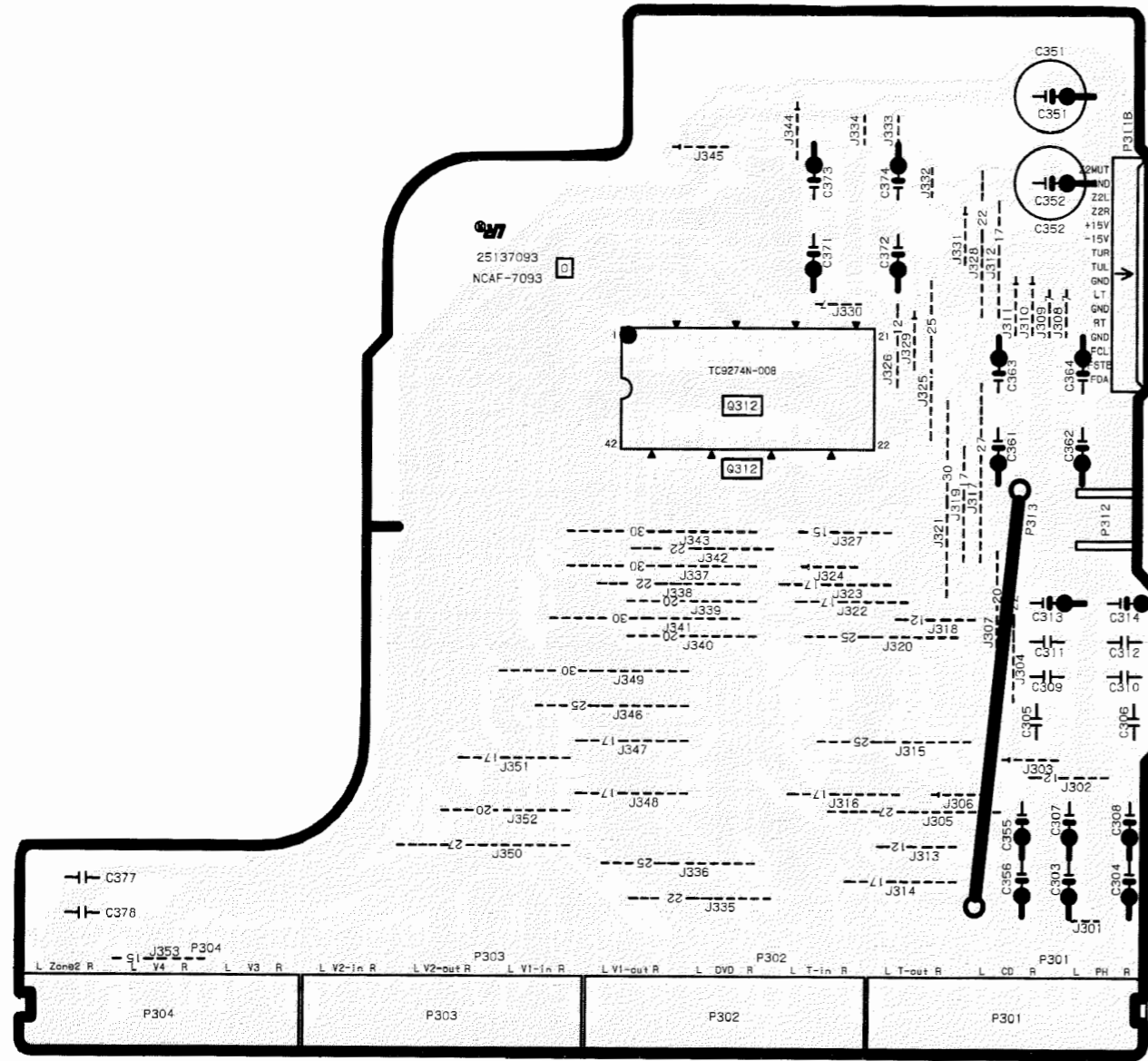

COMPONENT SIDE

INPUT TERMINAL PC BOARD

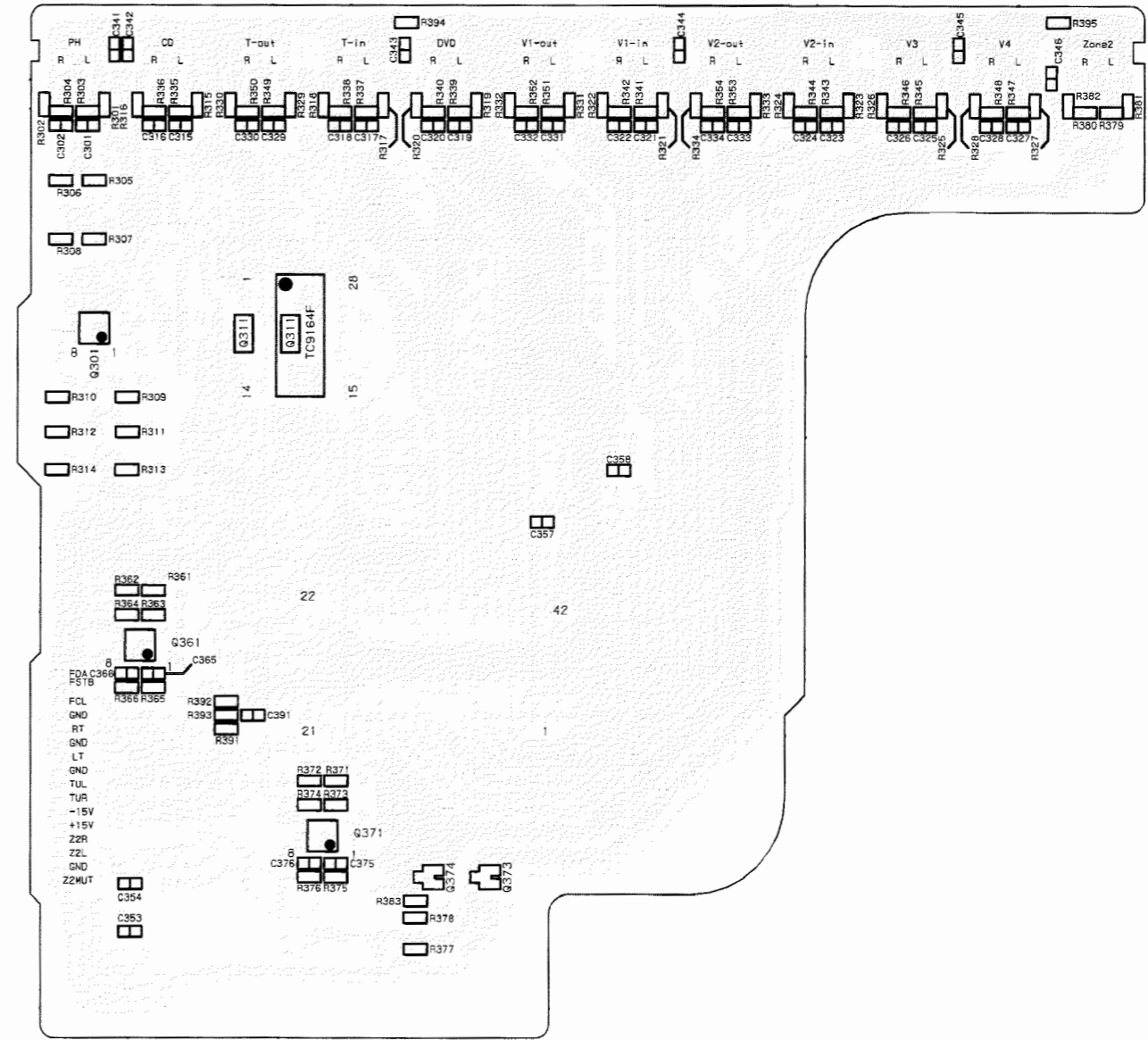

SOLDERING SIDE

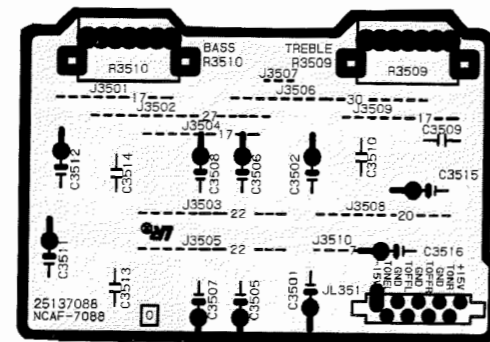

COMPONENT SIDE

TONE CONTROL CIRCUIT PC BOARD

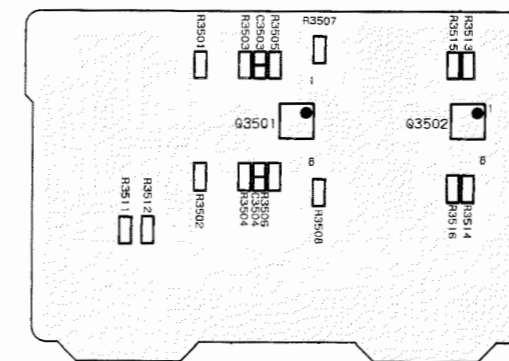

SOLDERING SIDE

**SCHEMATIC DIAGRAM
INPUT SECTION**

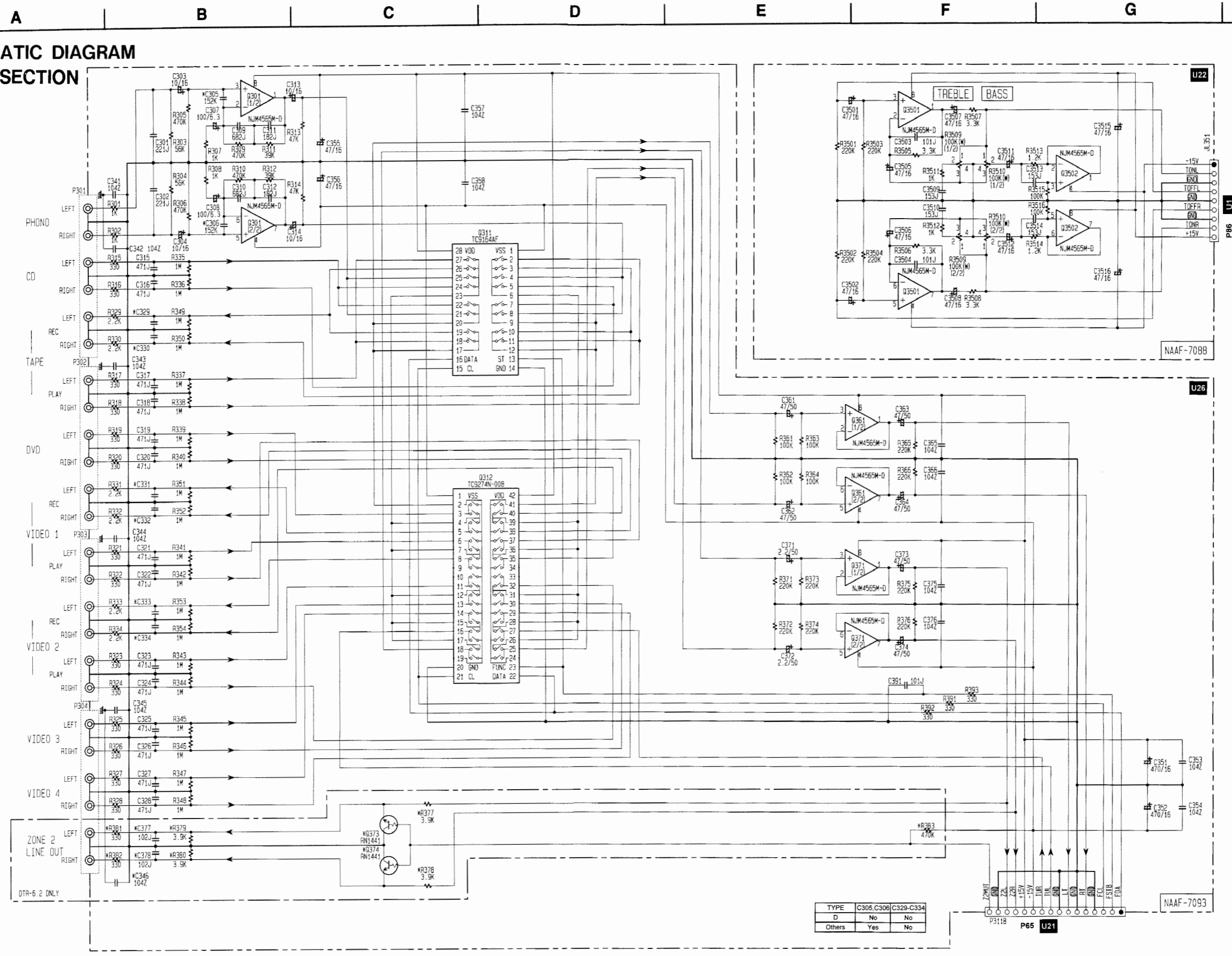

PC BOARD VIEWS FROM SOLDERING SIDE

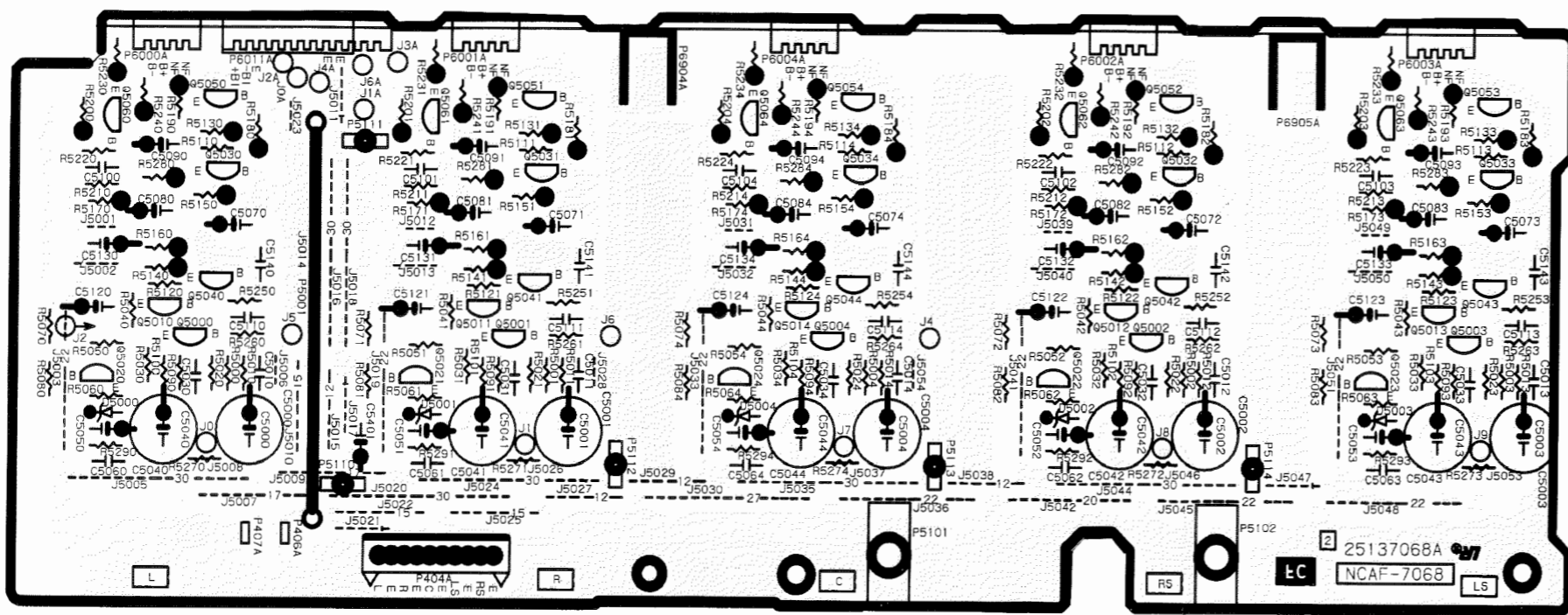

POWER AMPLIFIER A PC BOARD

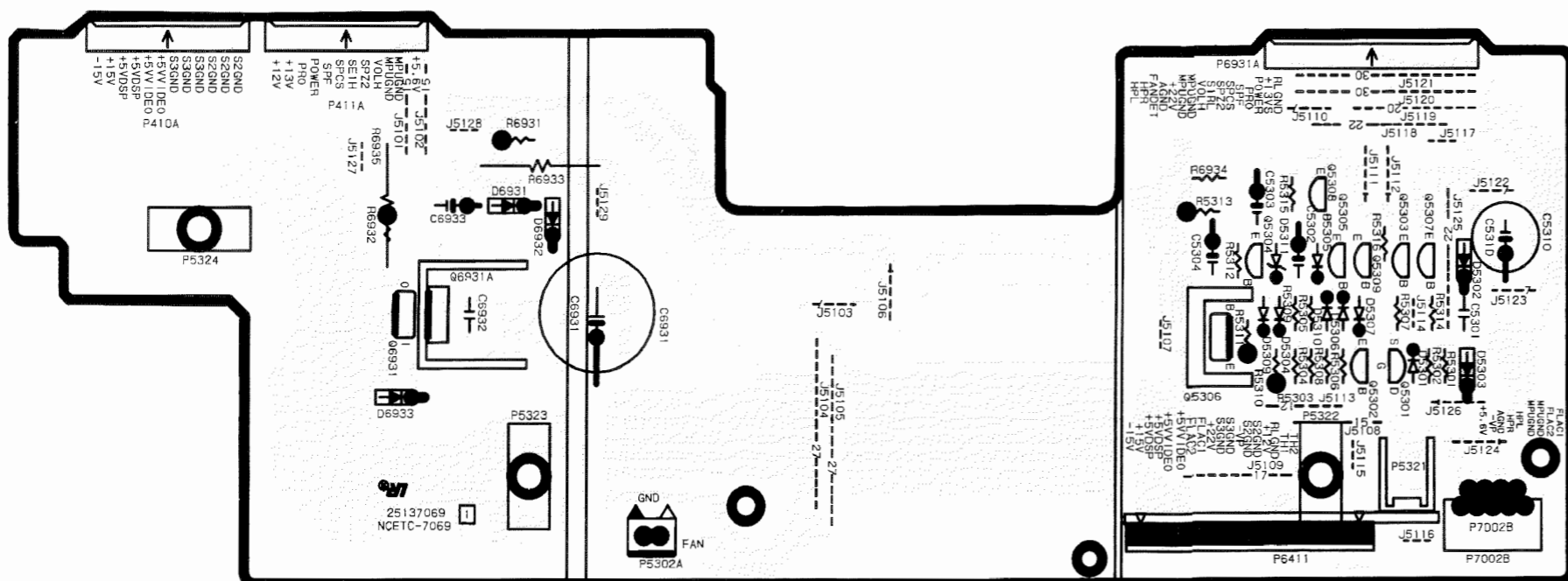

TERMINAL PC BOARD

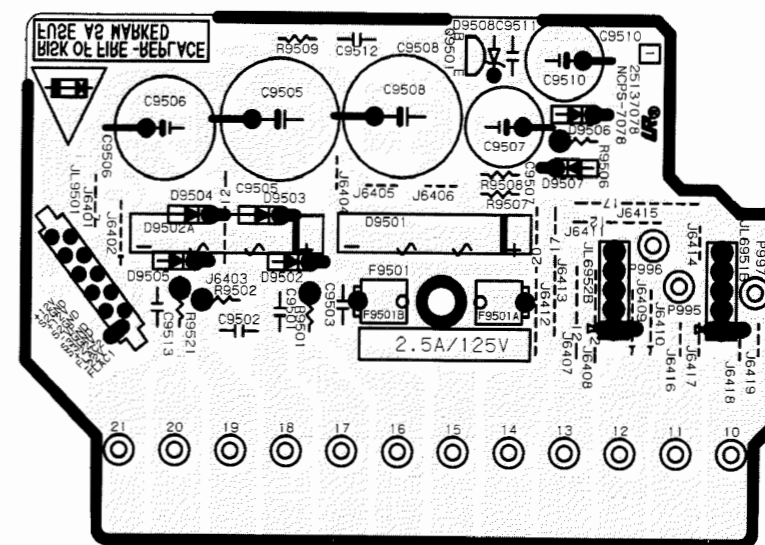

REGULATOR CIRCUIT PC BOARD

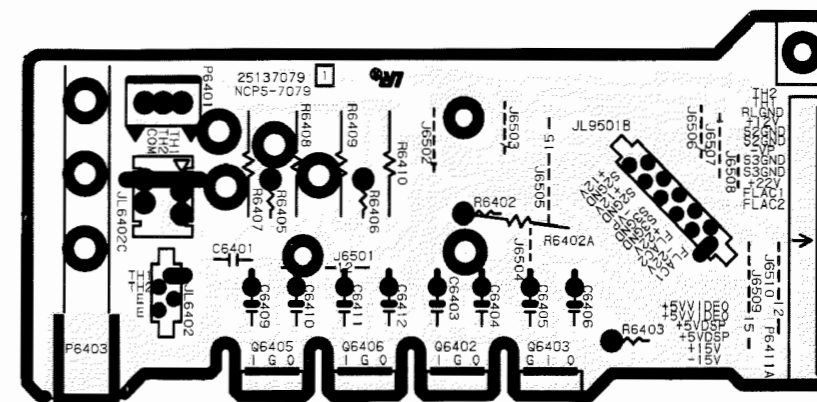

CONSTANT VOLTAGE PC BOARD

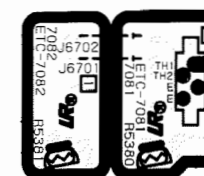

THERMAL DETECTOR CIRCUIT PC BOARD

SCHMATIC DIAGRAM
POWER AMPLIFIER SECTION A

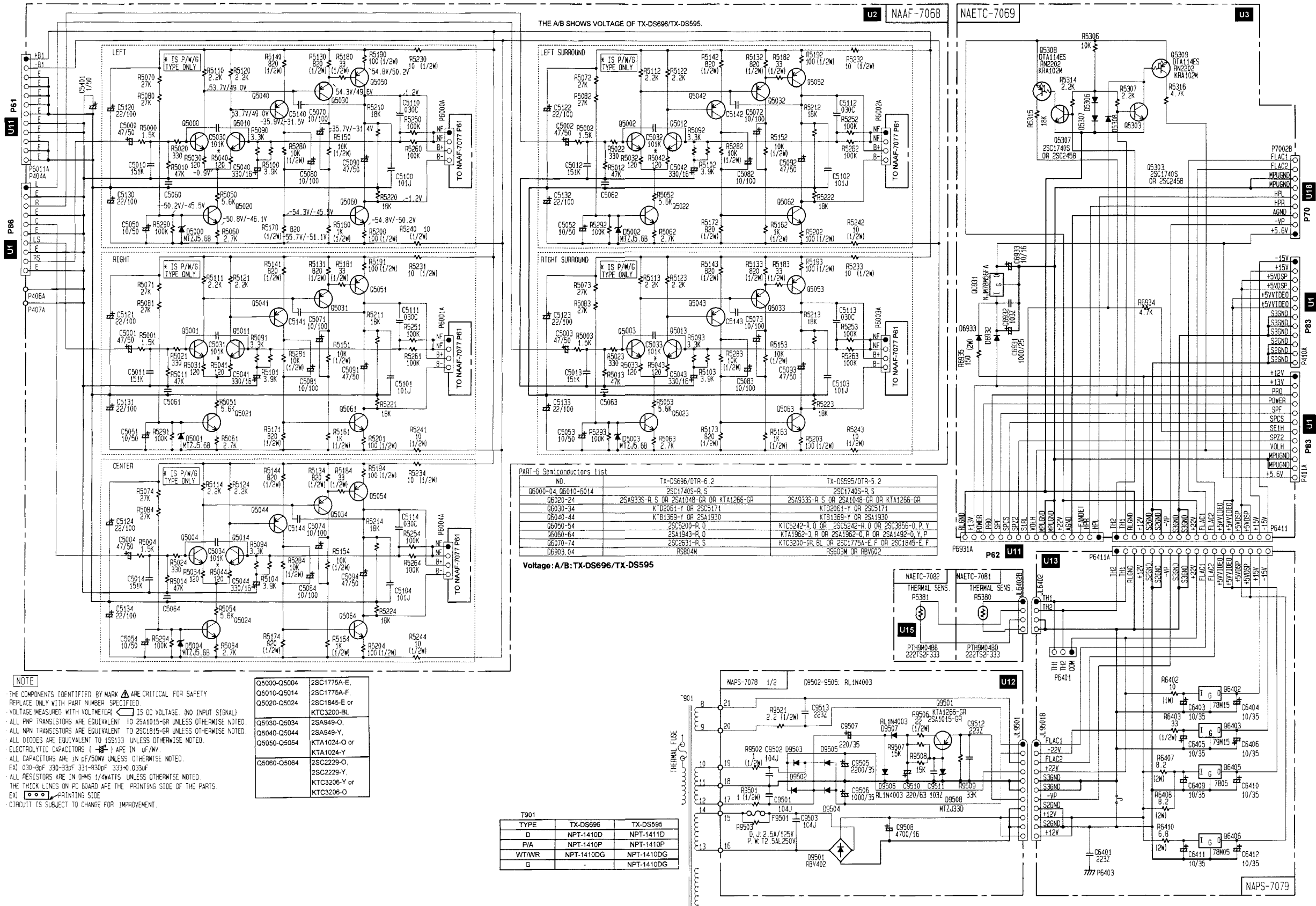

PC BOARD VIEW FROM SOLDERING SIDE

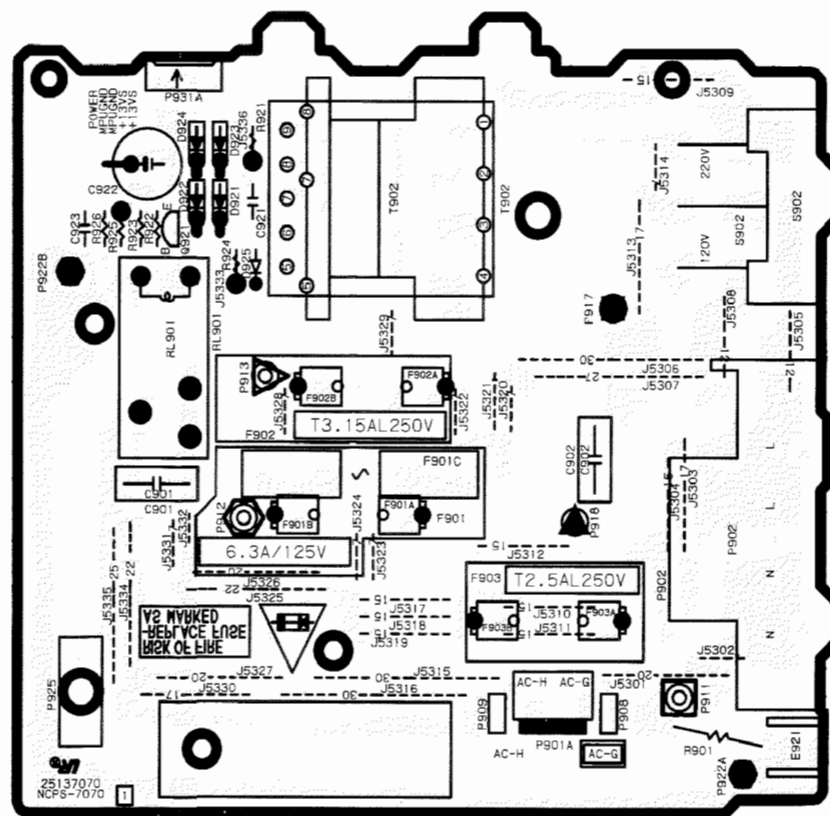
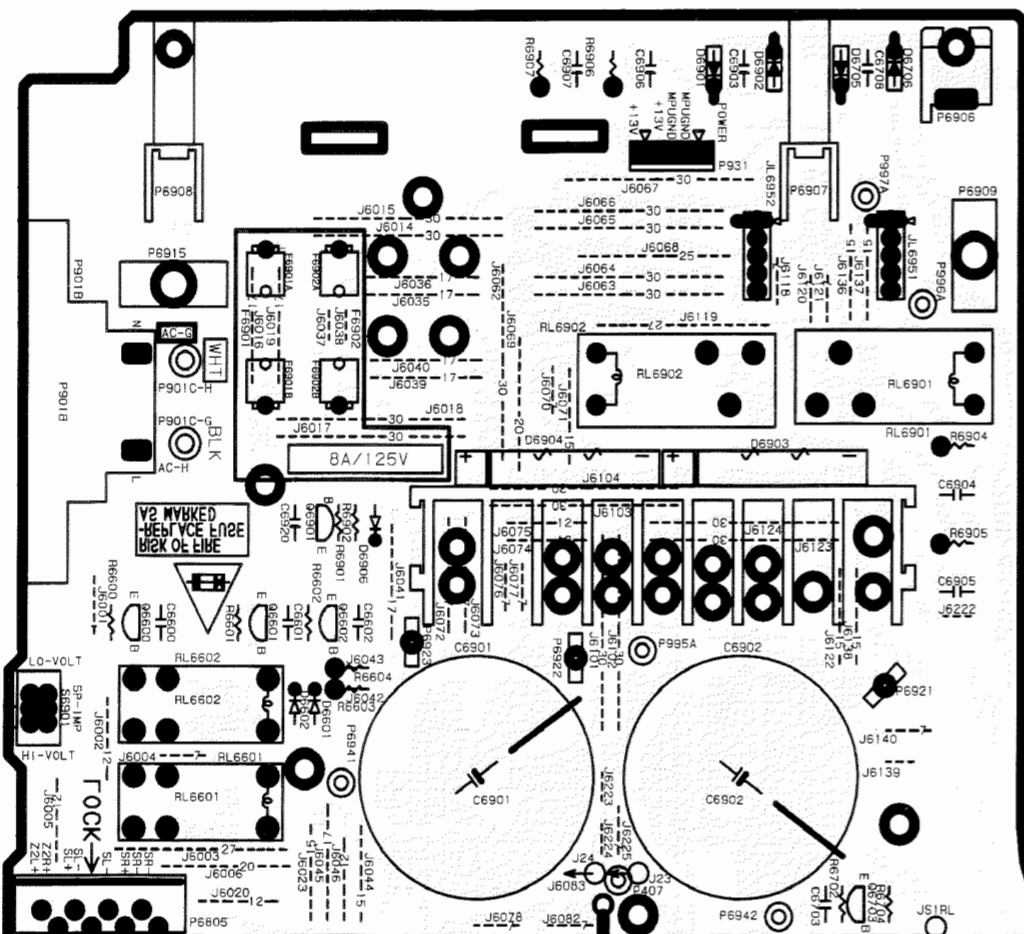

PRIMARY CIRCUIT PC BOARD

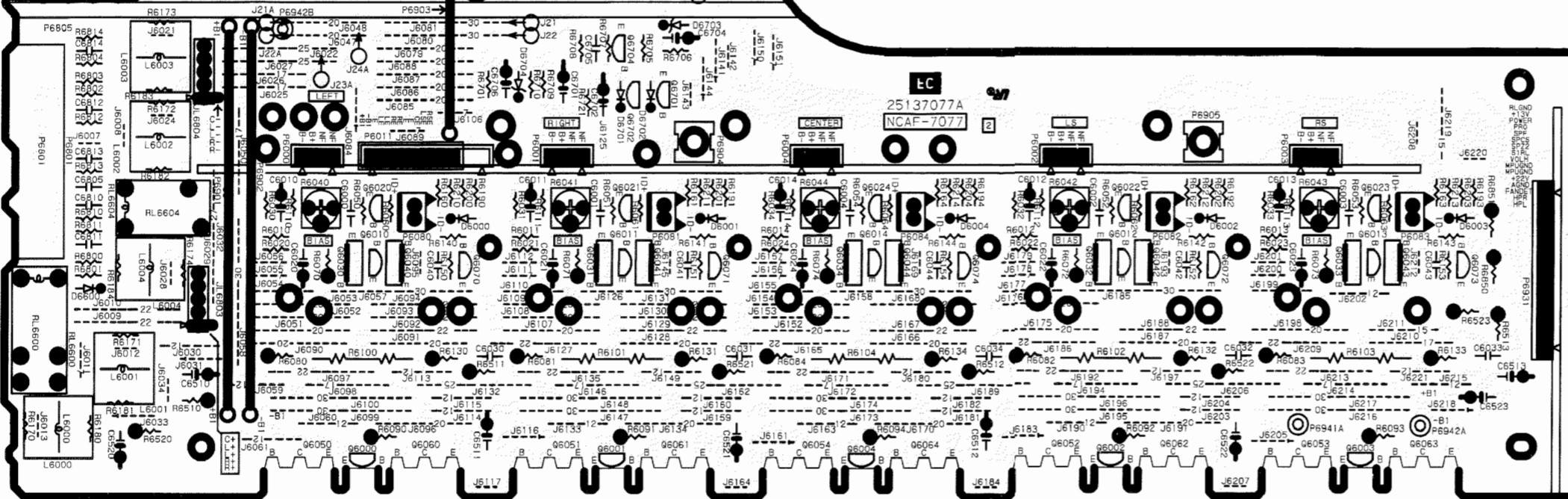

POWER AMPLIFIER B PC BOARD

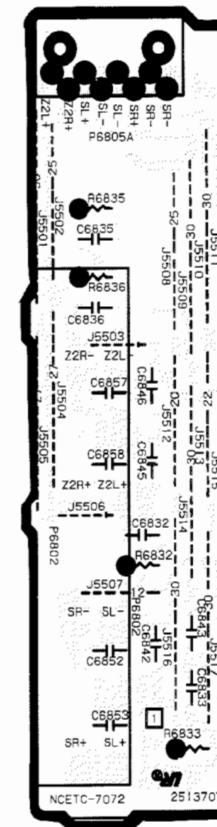

SPEAKER TERMINAL B PC BOARD

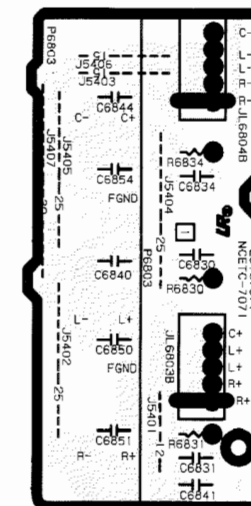

SPEAKER TERMINAL A PC BOARD

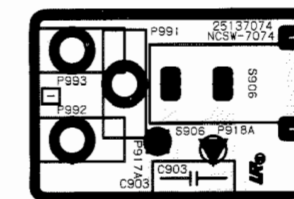

POWER SWITCH PC BOARD

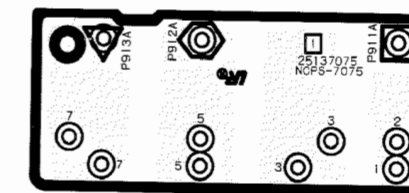

TERMINAL PC BOARD

A B C D E F G

**SCHEMATIC DIAGRAM
POWER AMPLIFIER SECTION 2**

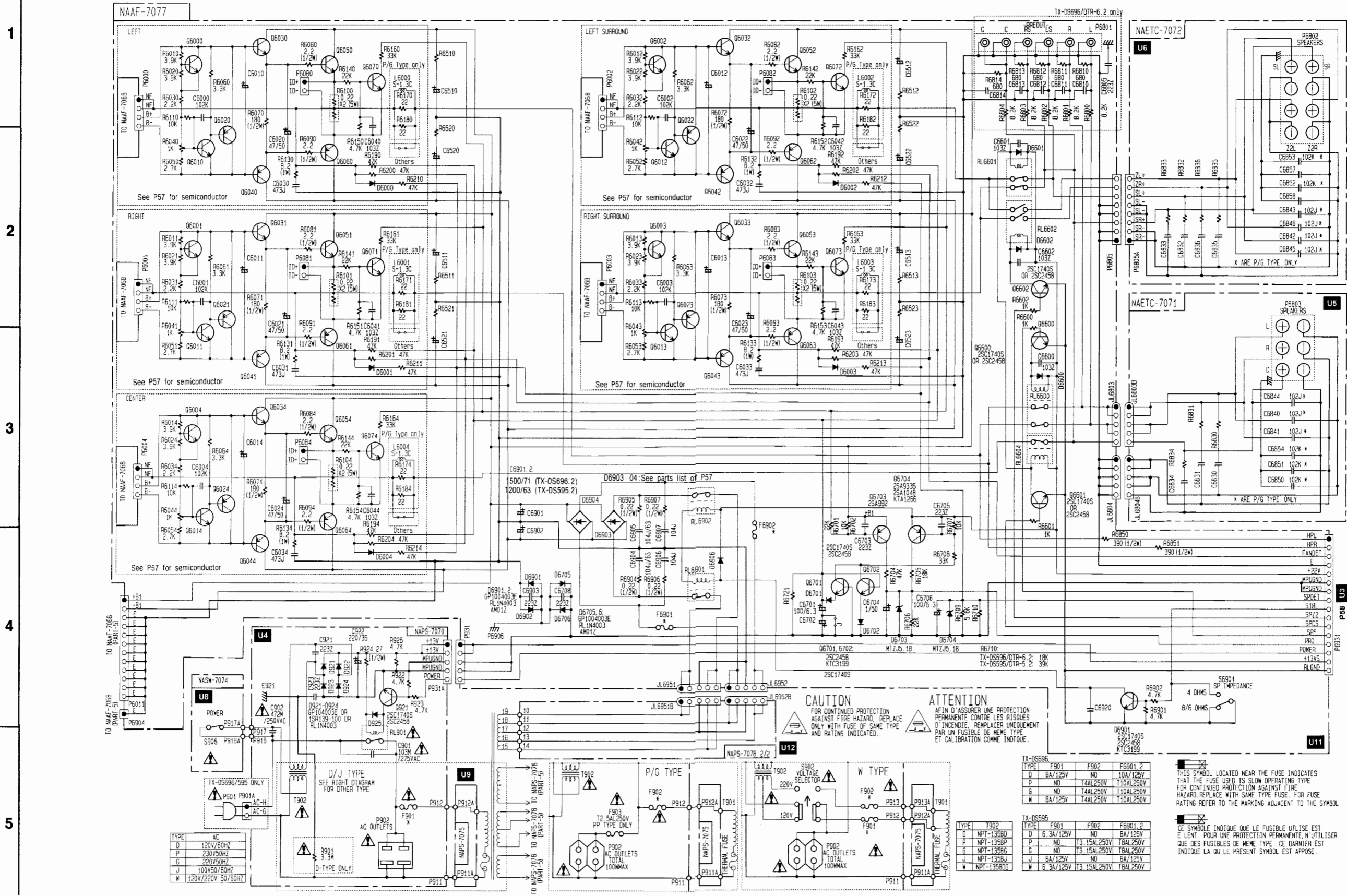

PC BOARD VIEWS FROM SOLDERING SIDE

COMPONENT SIDE PARTS VIEW

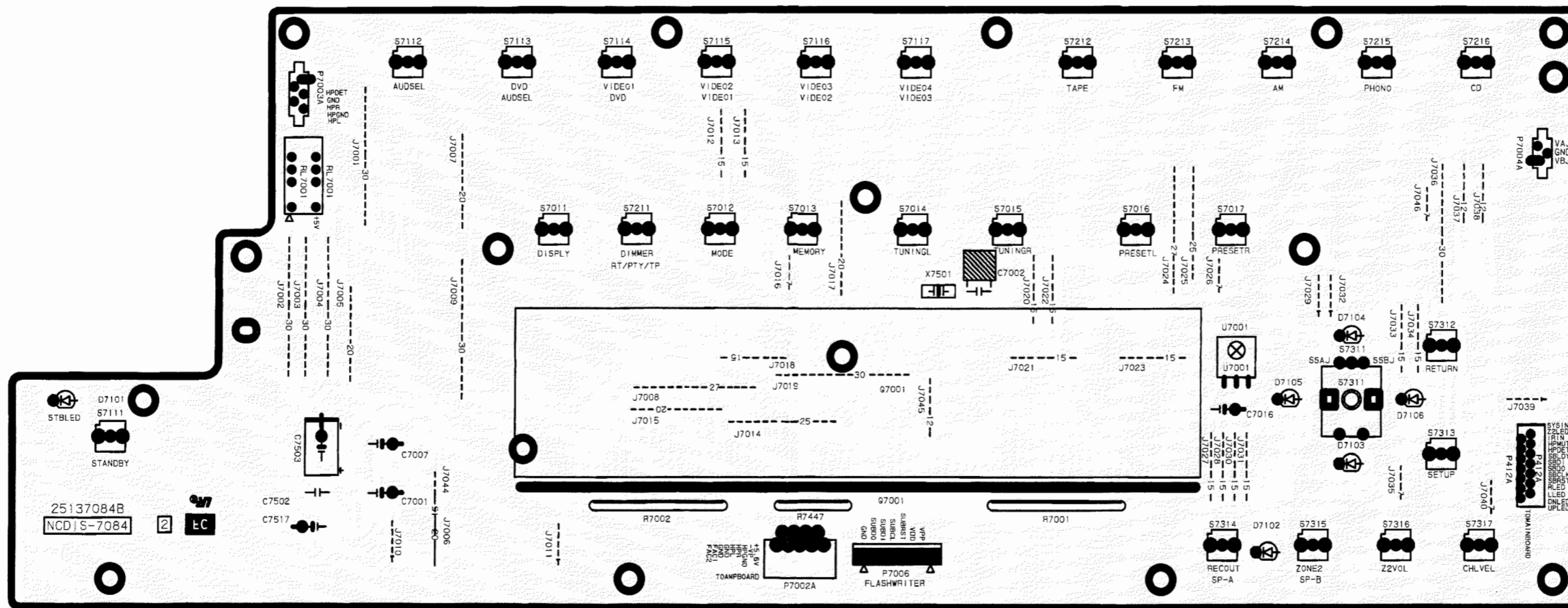

DISPLAY CIRCUIT PC BOARD

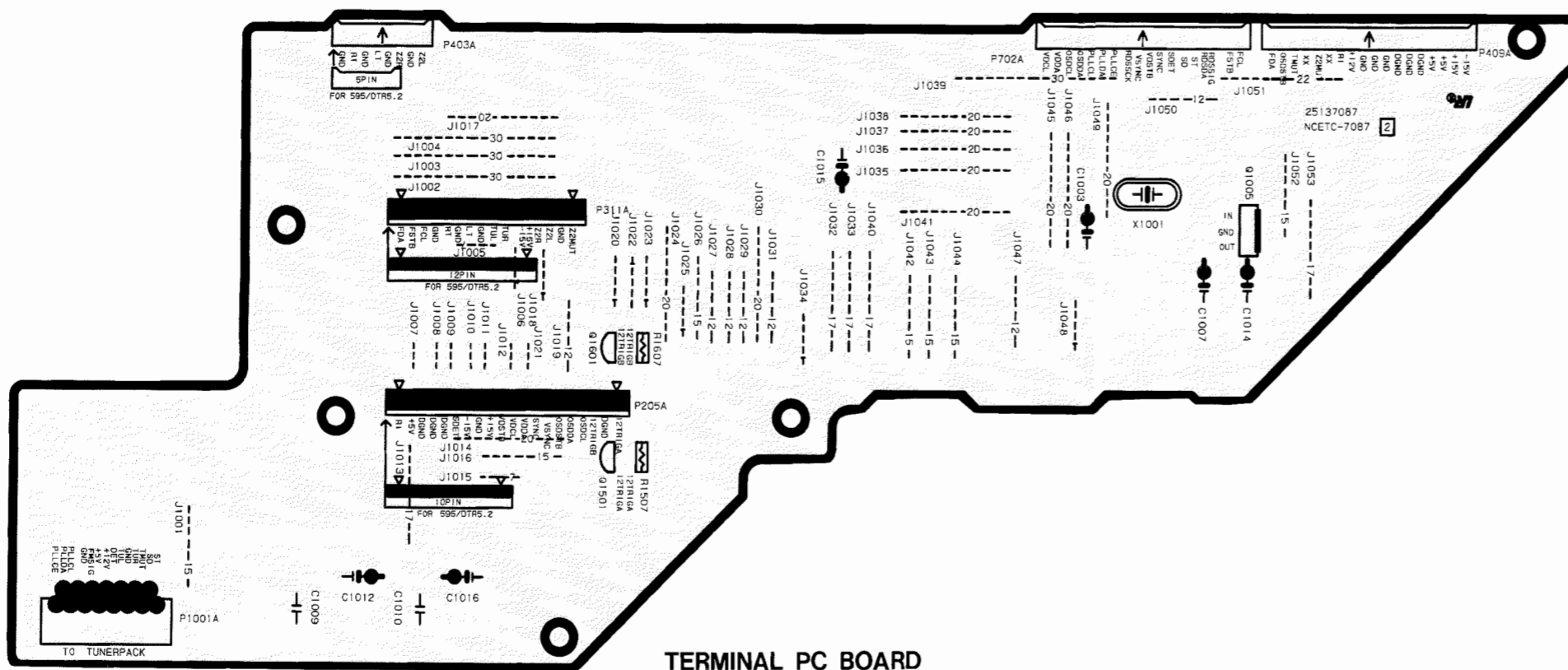

TERMINAL PC BOARD

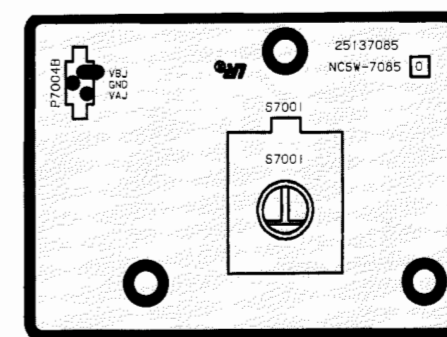

VOLUME PC BOARD

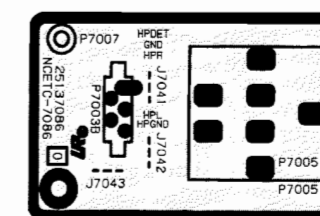

HEADPHONE TERMINAL PC BOARD

SCHEMATIC DIAGRAM DISPLAY SECTION

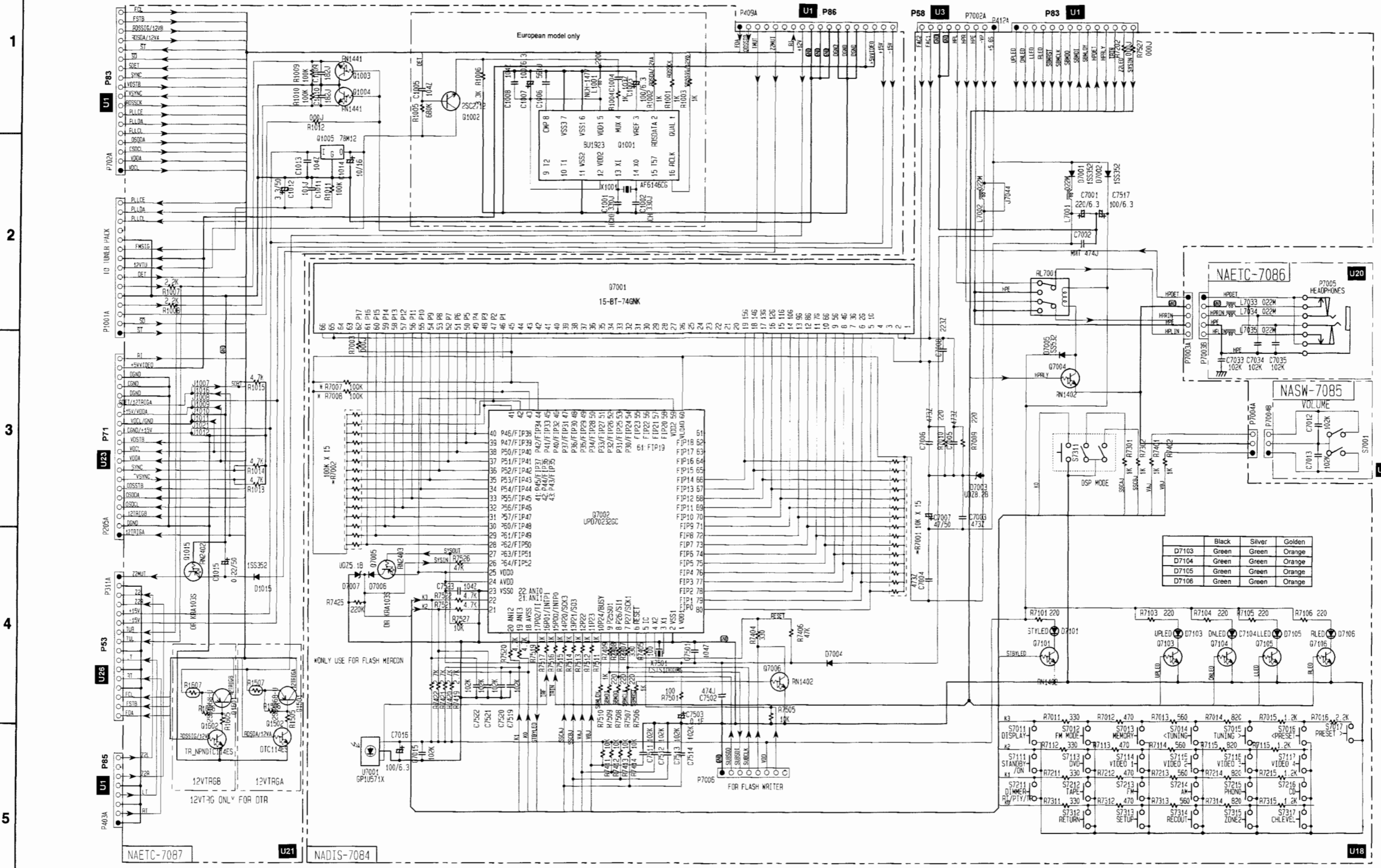

	Black	Silver	Golden
D7103	Green	Green	Orange
D7104	Green	Green	Orange
D7105	Green	Green	Orange
D7106	Green	Green	Orange

PC BOARD VIEWS FROM SOLDERING SIDE

SOLDERING SIDE VIEW

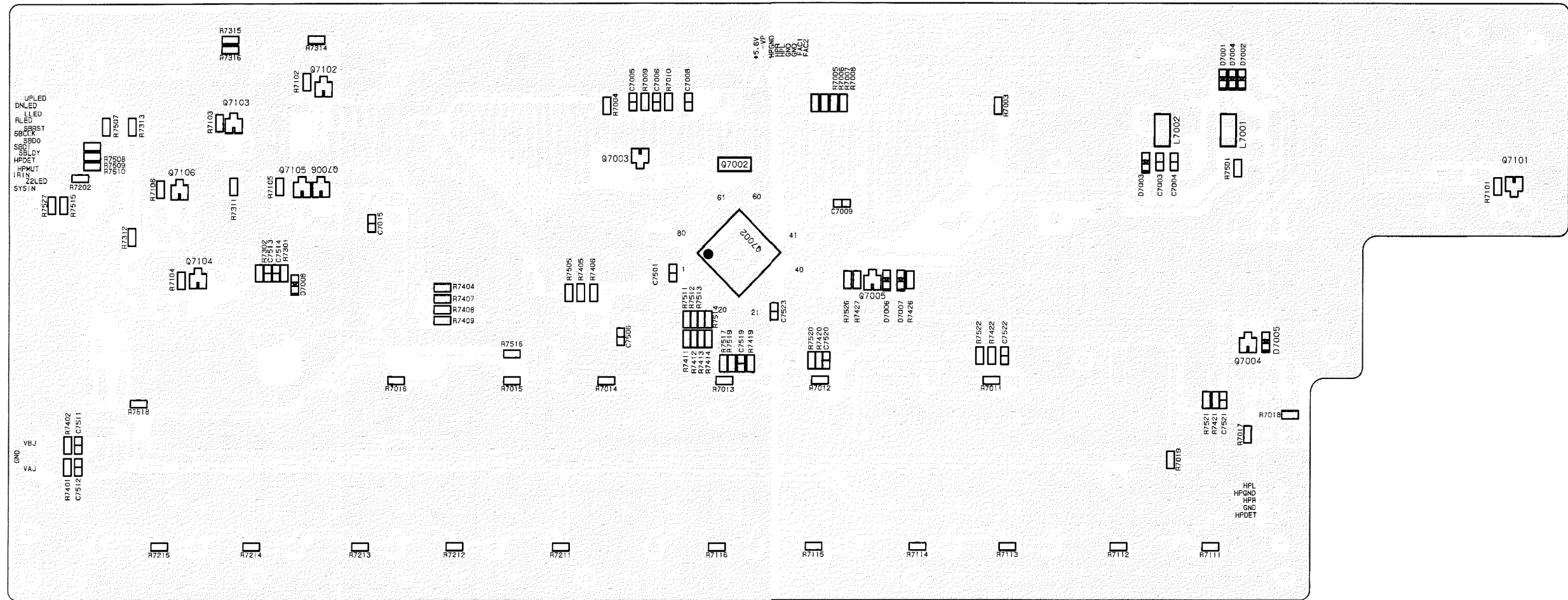

DISPLAY CIRCUIT PC BOARD

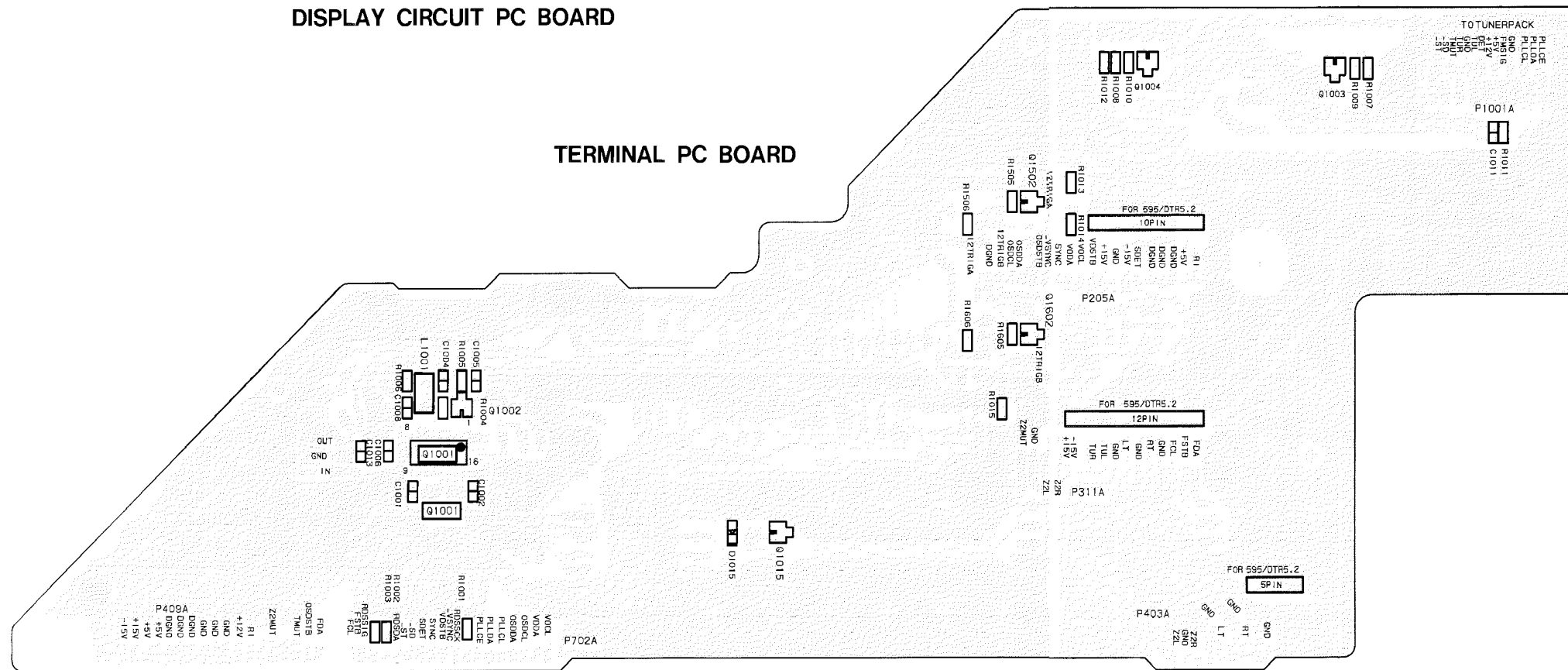

TERMINAL PC BOARD

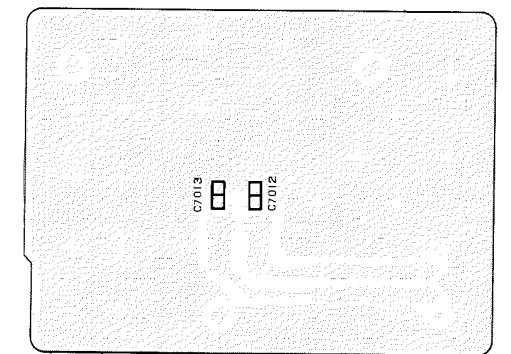

VOLUME PC BOARD

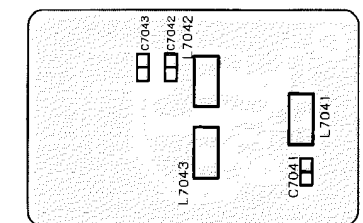

HEADPHONE TERMINAL PC BOARD

**SCHEMATIC DIAGRAM
DISPLAY SECTION**

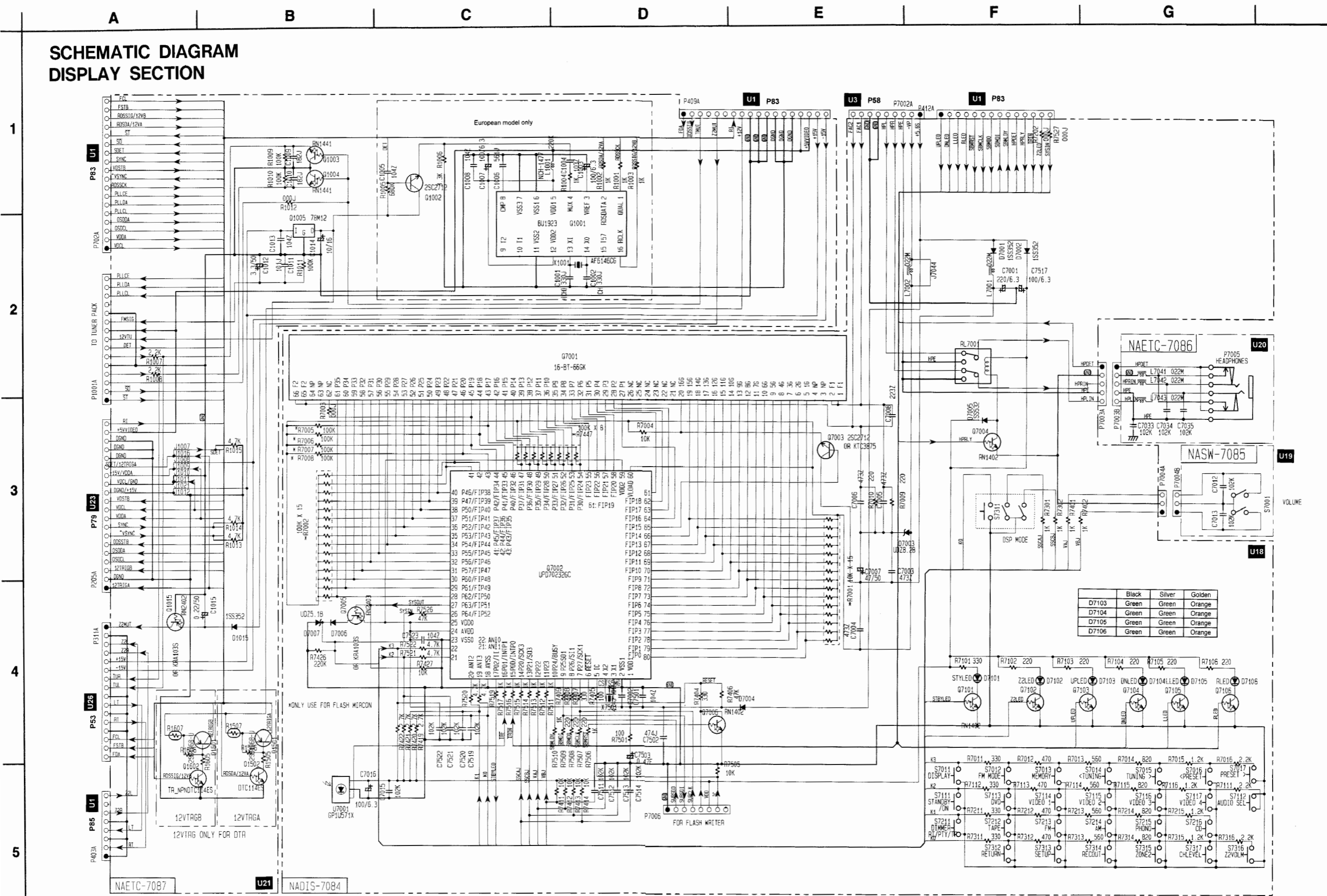

D7103	Black	Silver	Golden
D7104	Green	Green	Orange
D7105	Green	Green	Orange
D7106	Green	Green	Orange

**SCHEMATIC DIAGRAM
VIDEO SECTION**

1
2
3
4
5

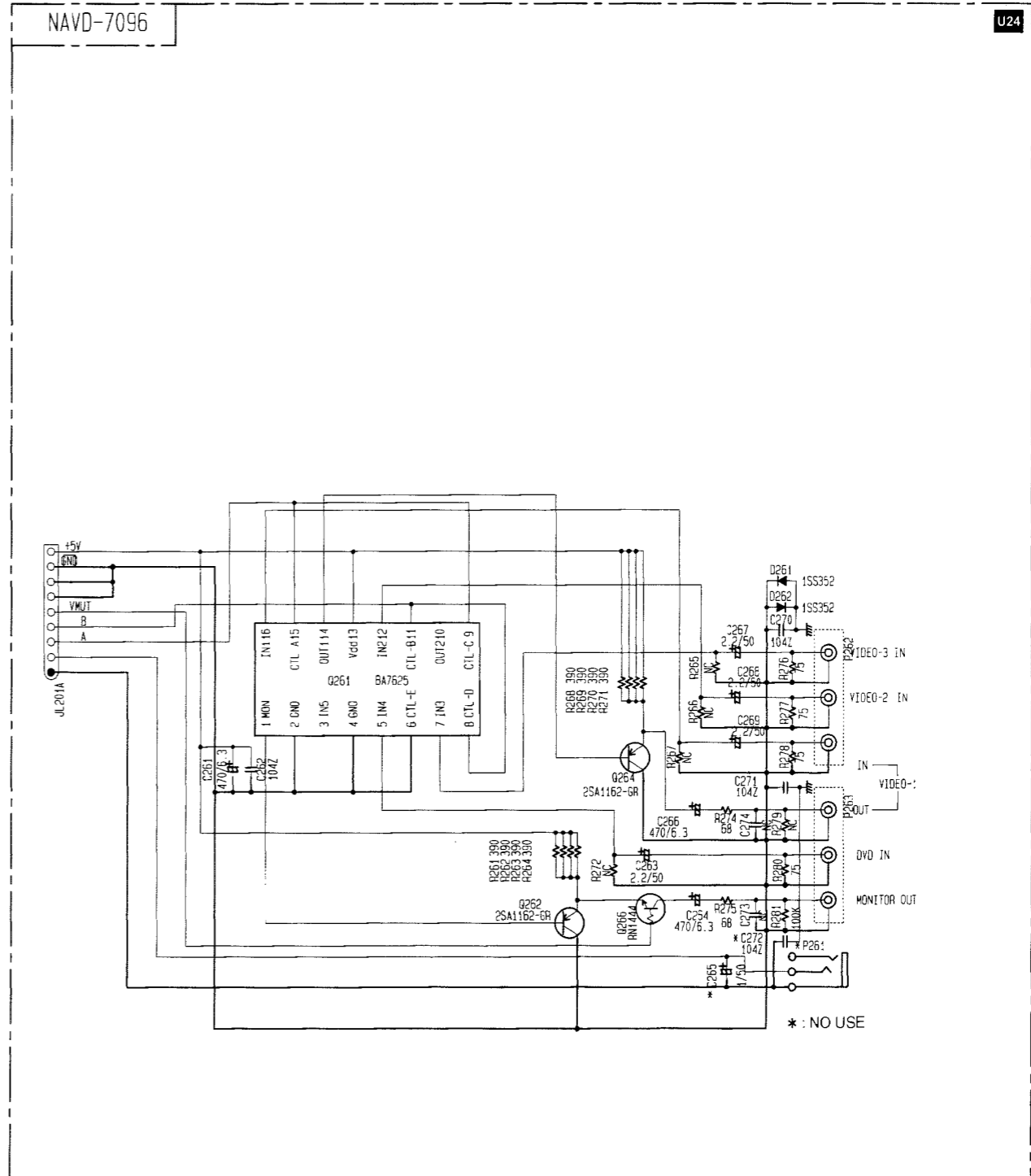
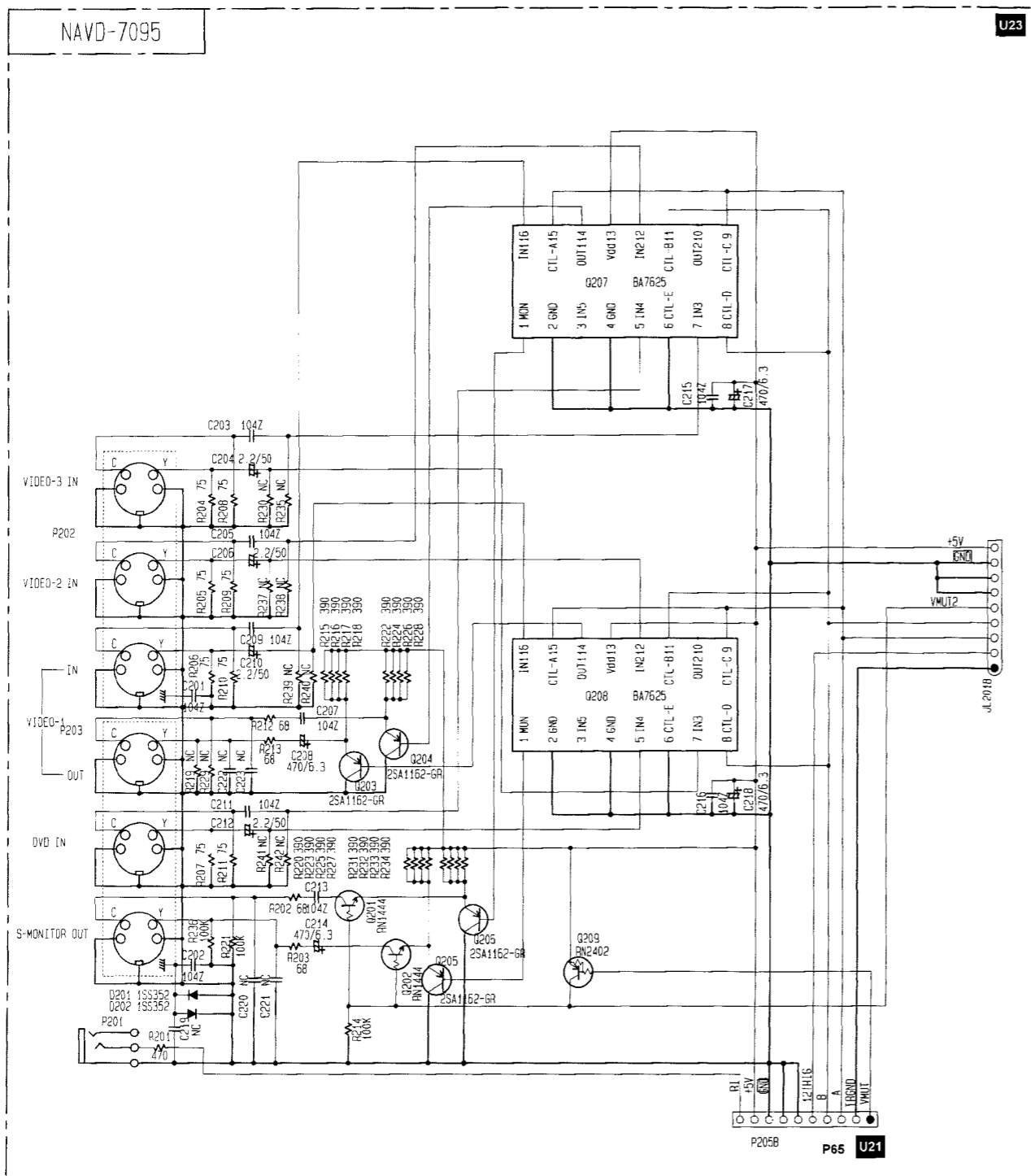

PC BOARD VIEW FROM SOLDERING SIDE

COMPONENT SIDE PARTS VIEW

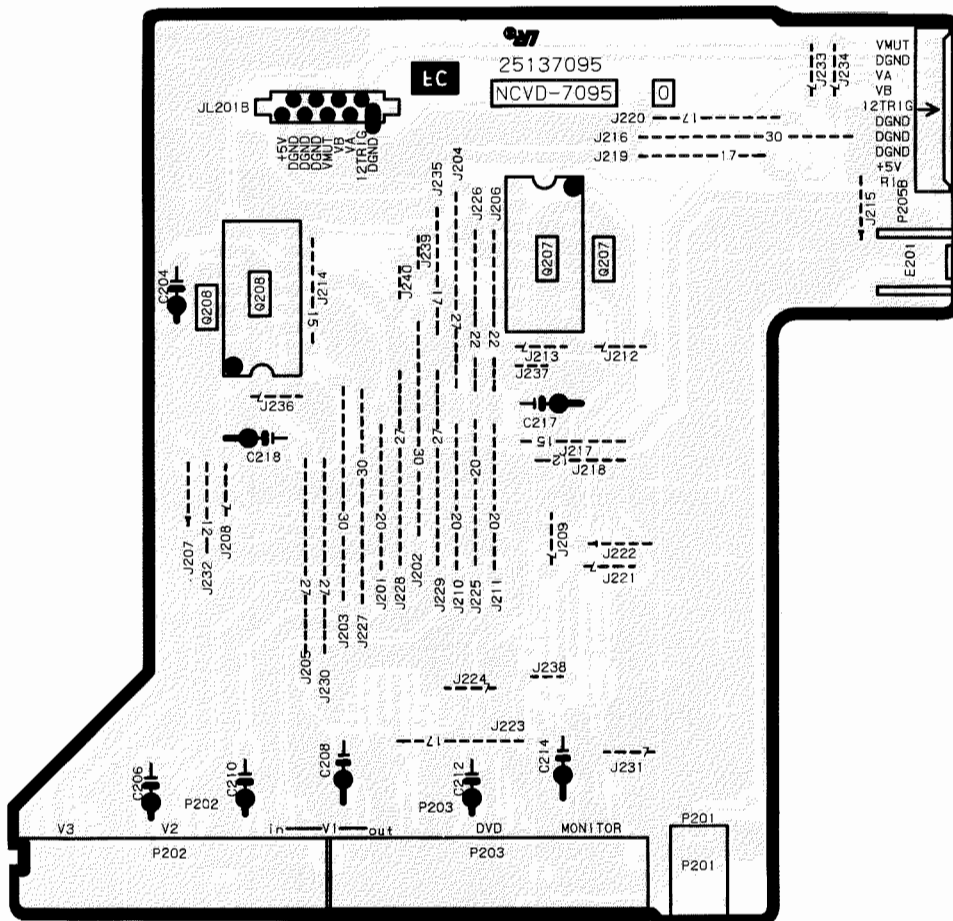

S VIDEO TERMINAL PC BOARD

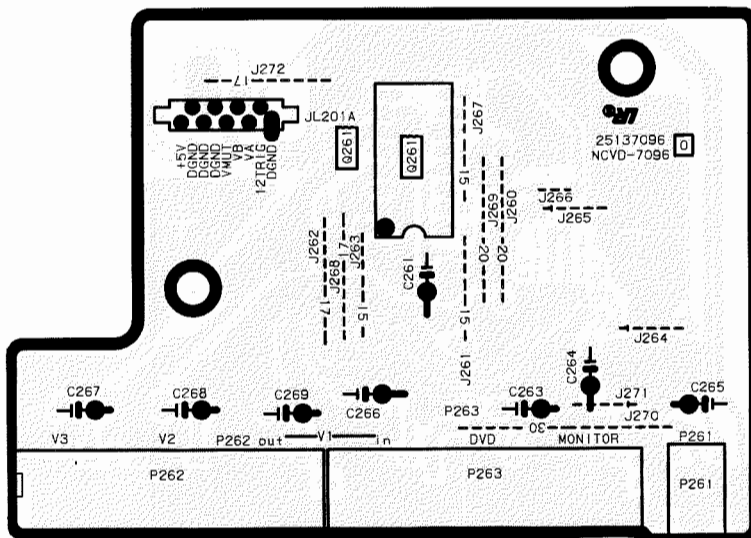

COMPOSITE VIDEO PC BOARD

PC BOARD VIEW FROM SOLDERING SIDE

SOLDERING SIDE PARTS VIEW

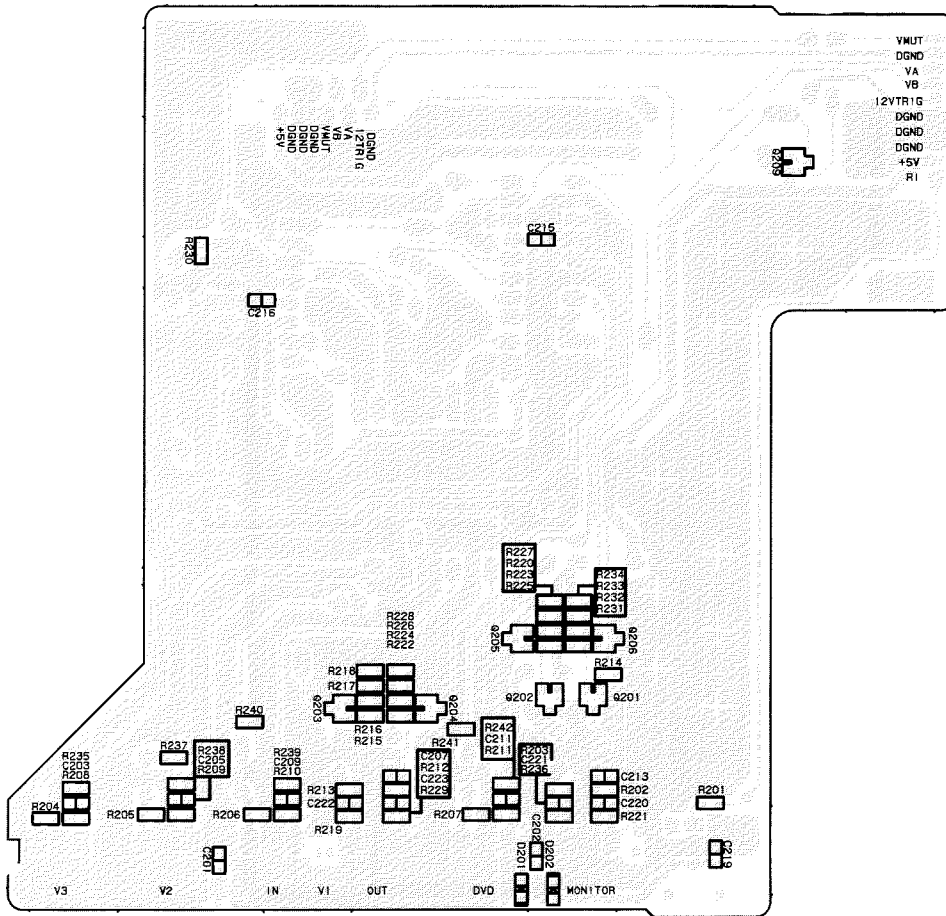

S VIDEO TERMINAL PC BOARD

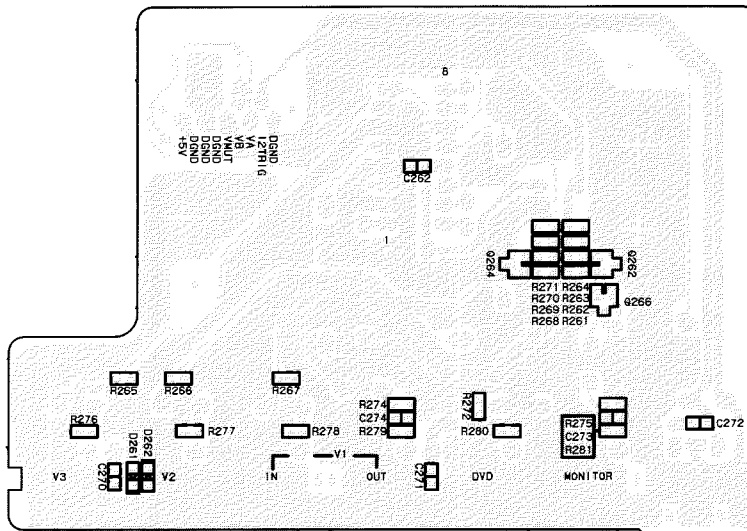

COMPOSITE VIDEO PC BOARD

PC BOARD VIEW FROM SOLDERING SIDE

COMPONENT SIDE PARTS VIEW

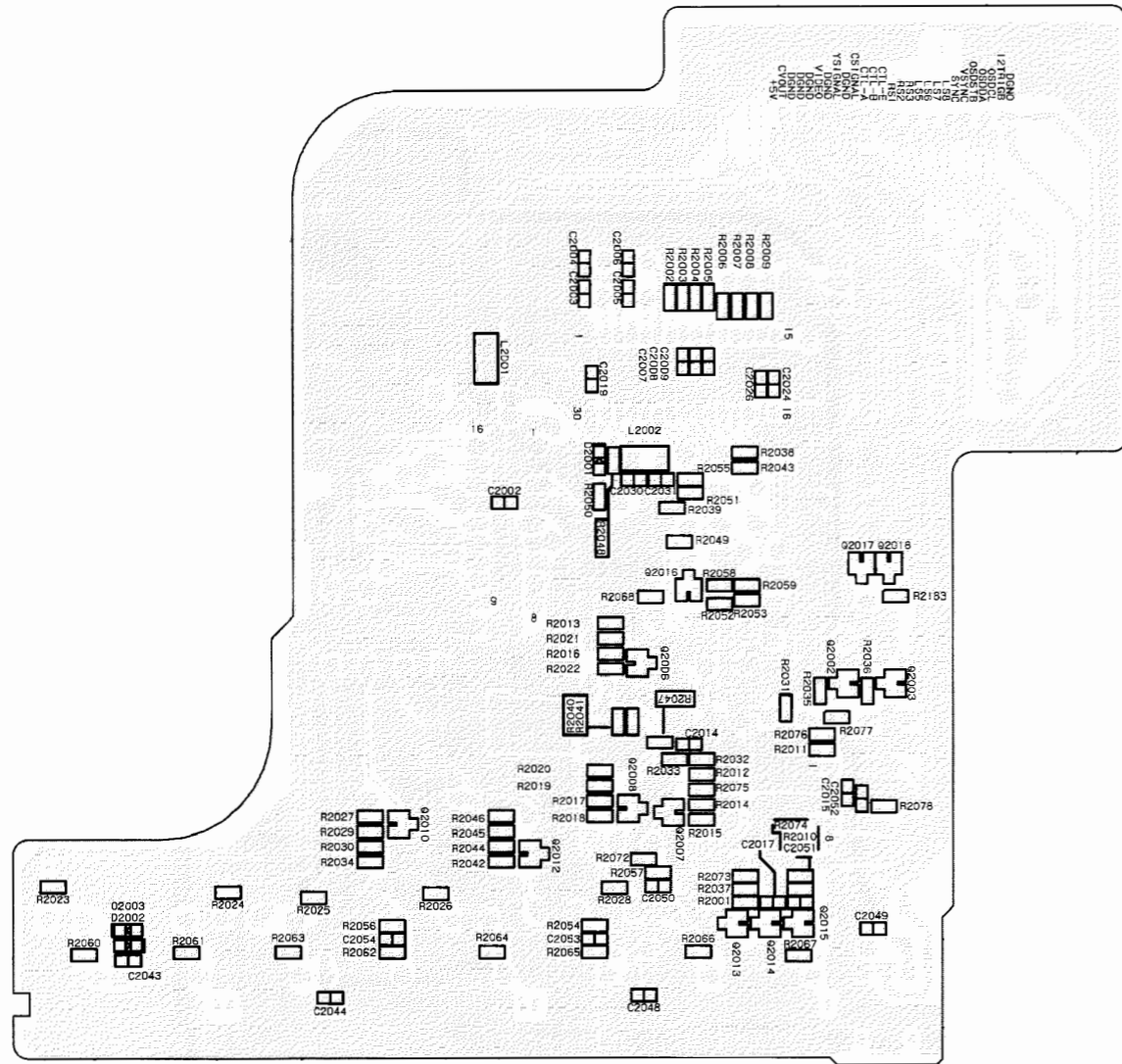

S VIDEO TERMINAL PC BOARD

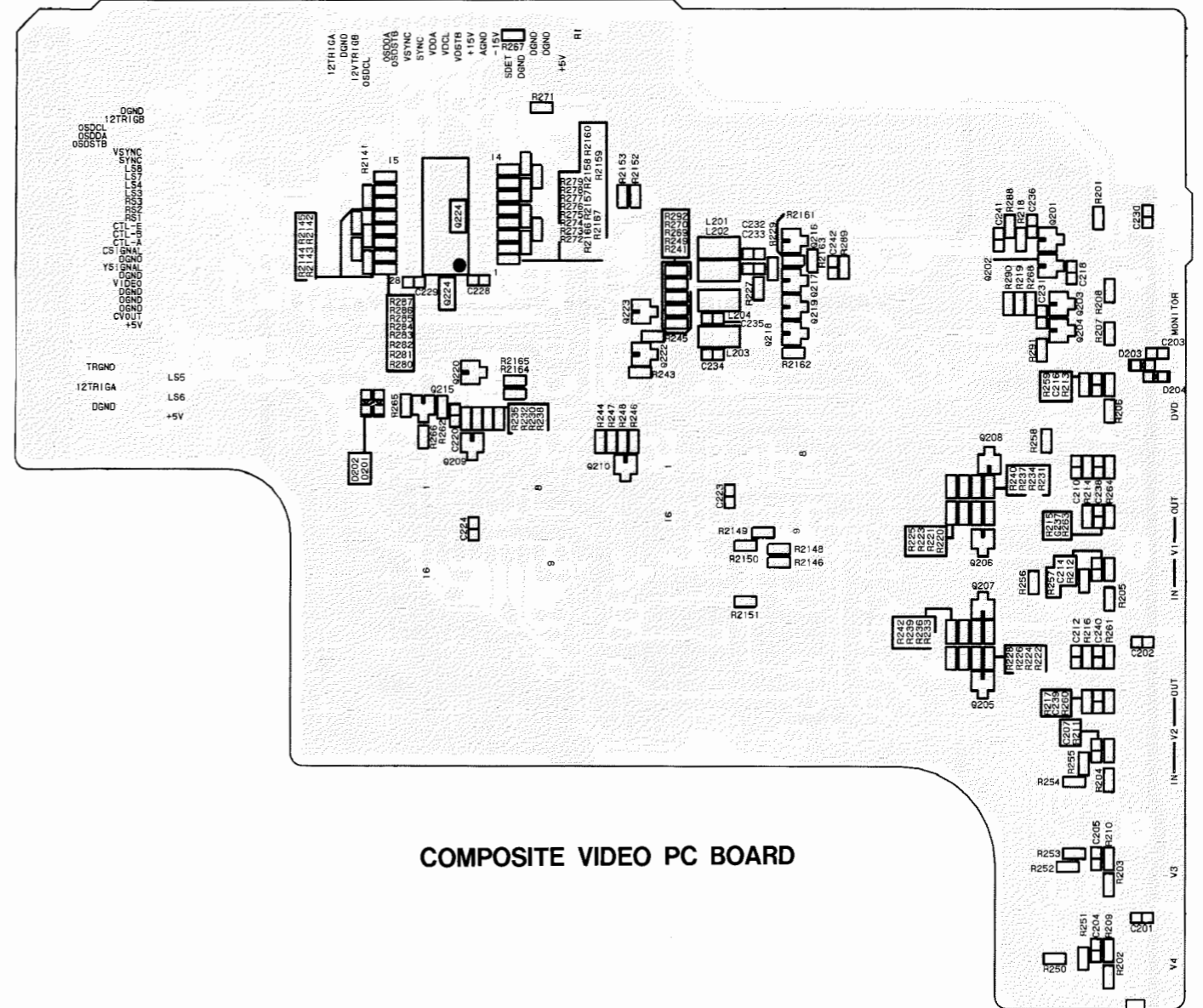

COMPOSITE VIDEO PC BOARD

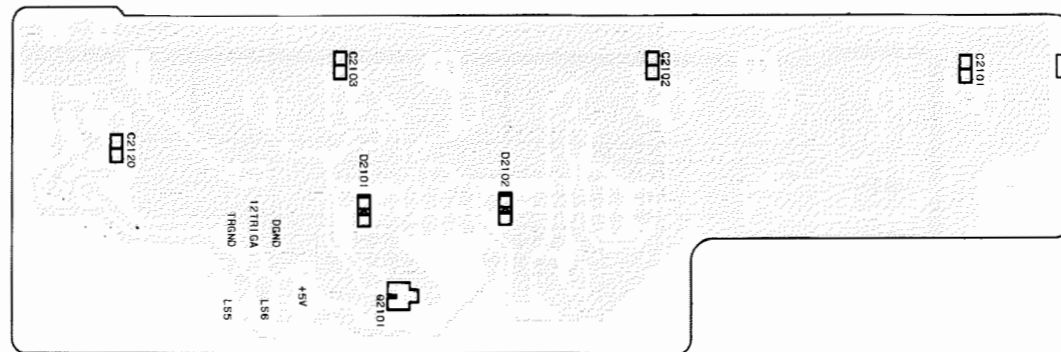

COMPONENT VIDEO TERMINAL PC BOARD

PC BOARD VIEWS FROM SOLDERING SIDE

SOLDERING SIDE PARTS VIEW

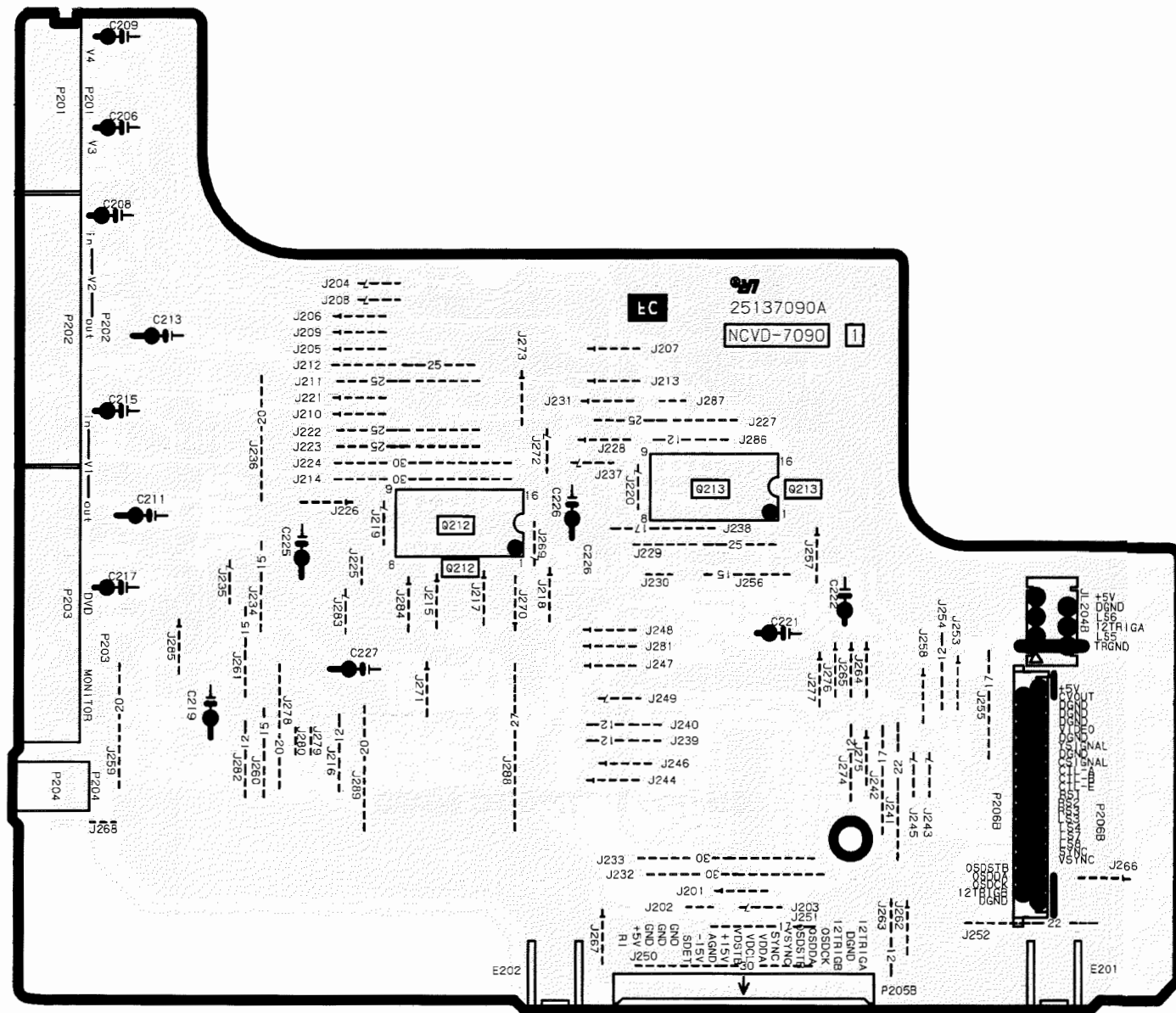

S VIDEO TERMINAL PC BOARD

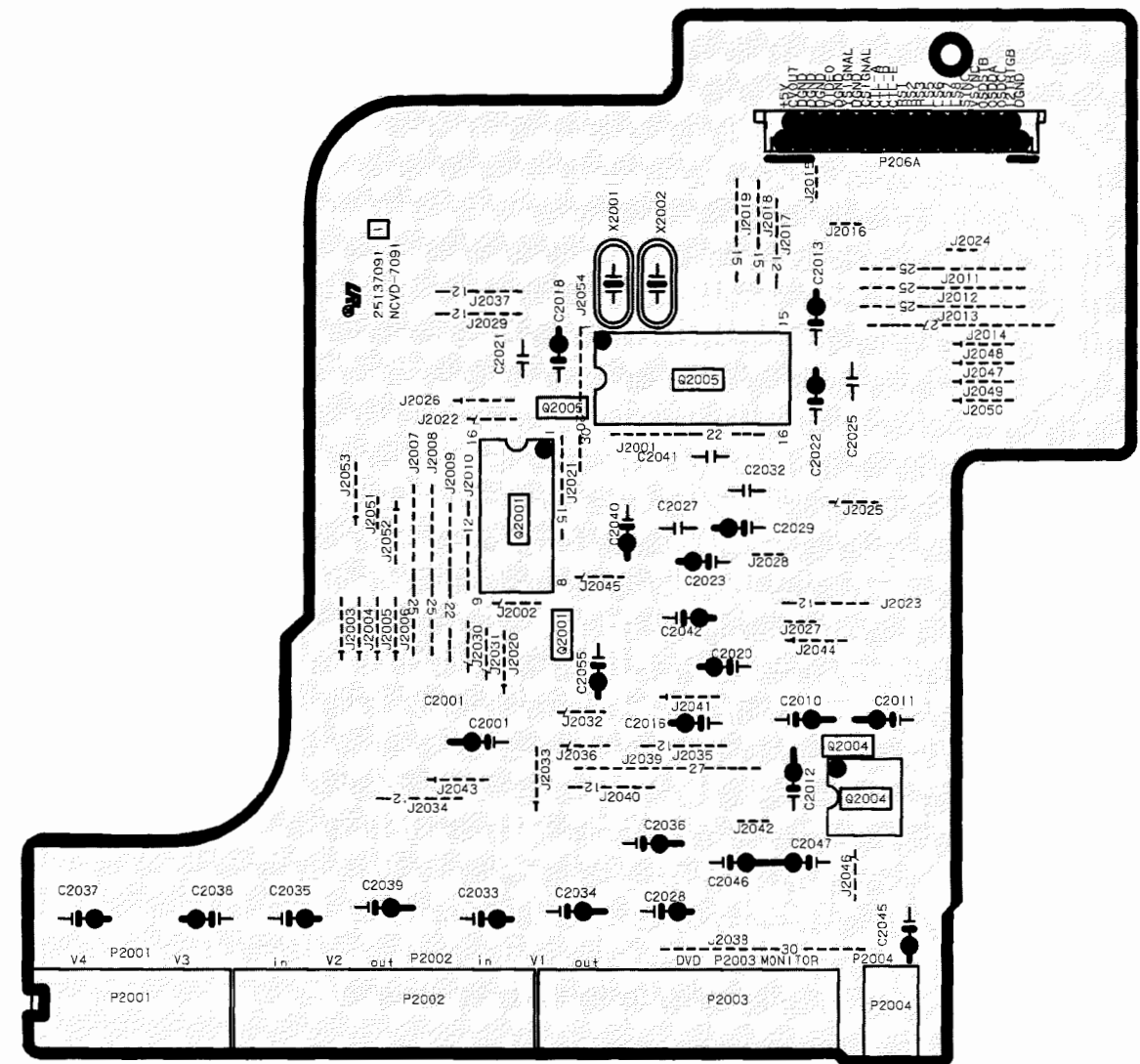

COMPOSITE VIDEO PC BOARD

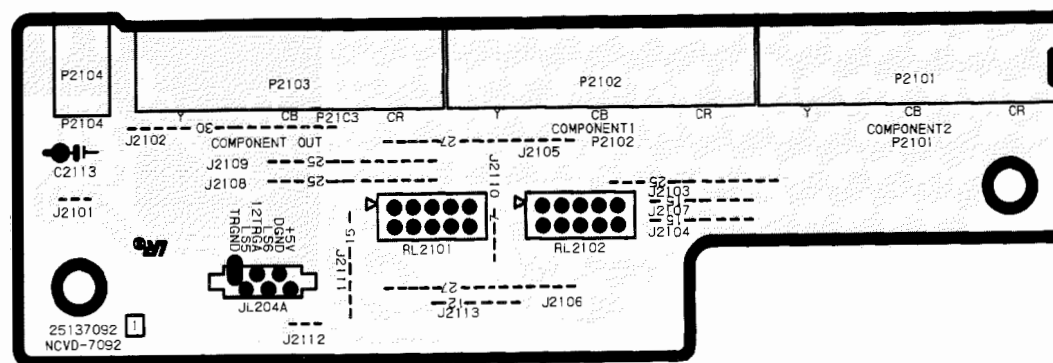

COMPONENT VIDEO TERMINAL PC BOARD

SCHMATIC DIAGRAM
VIDEO SECTION

1
2
3
4
5

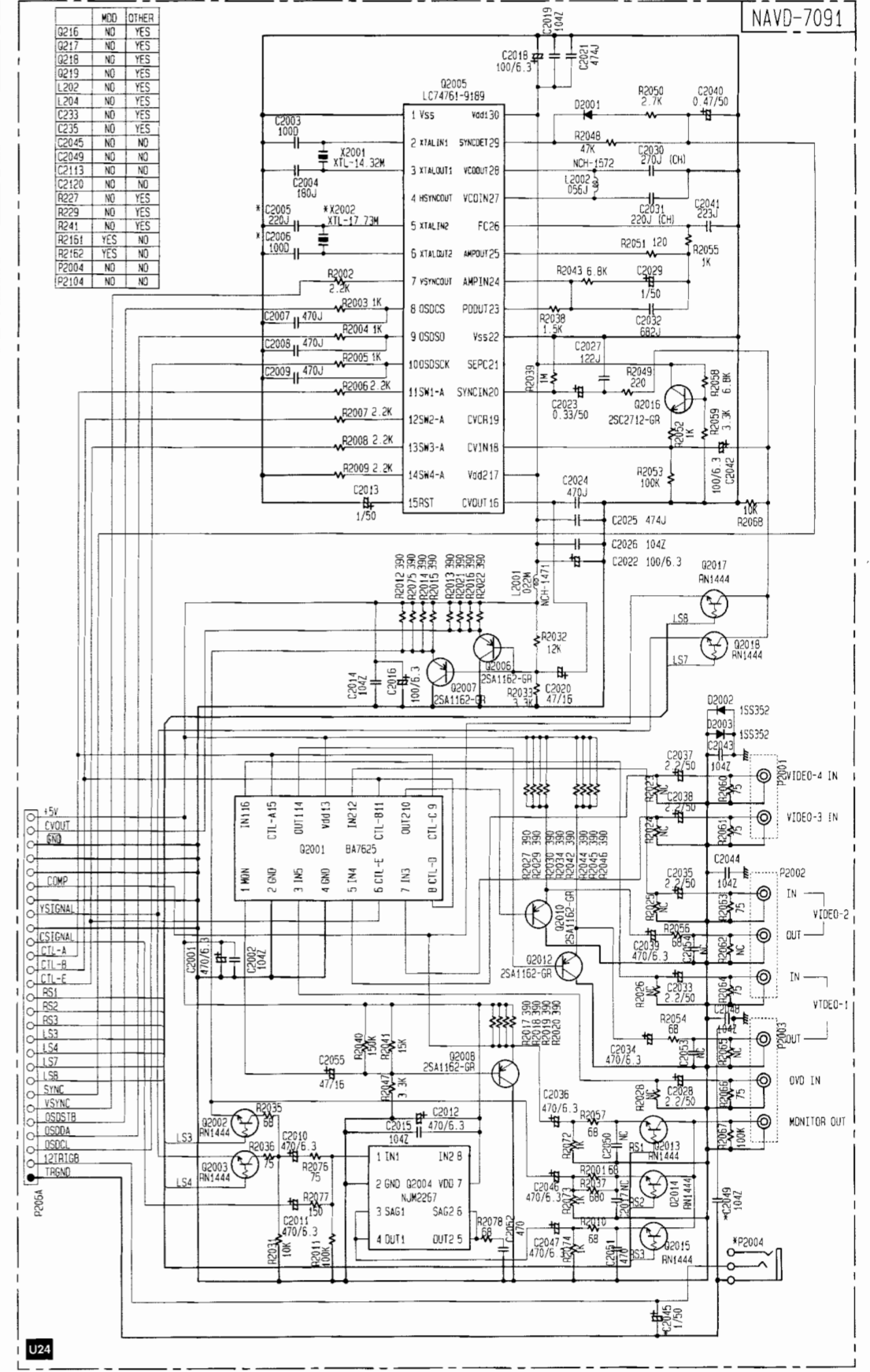
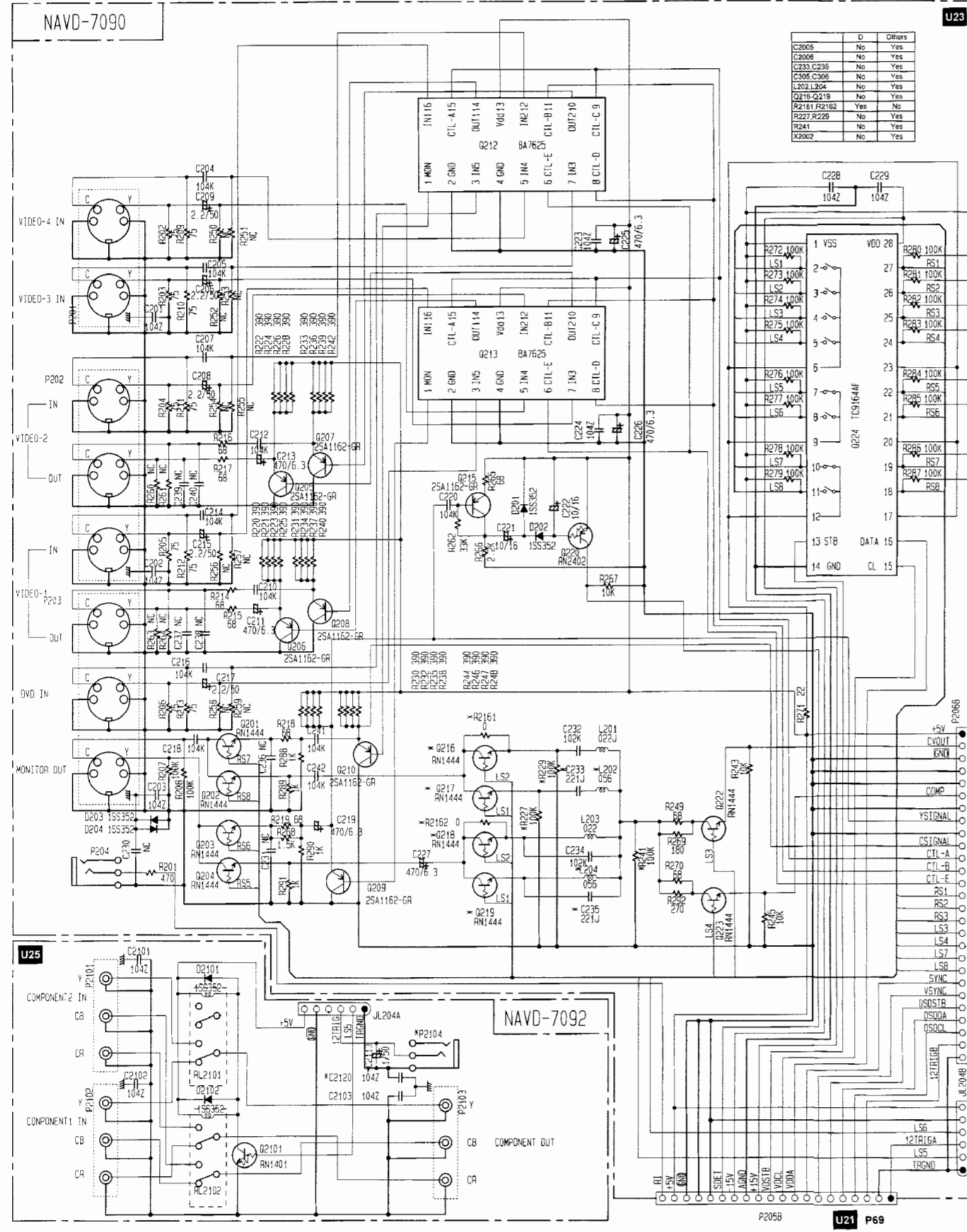

PC BOARD VIEW
DSP SECTION

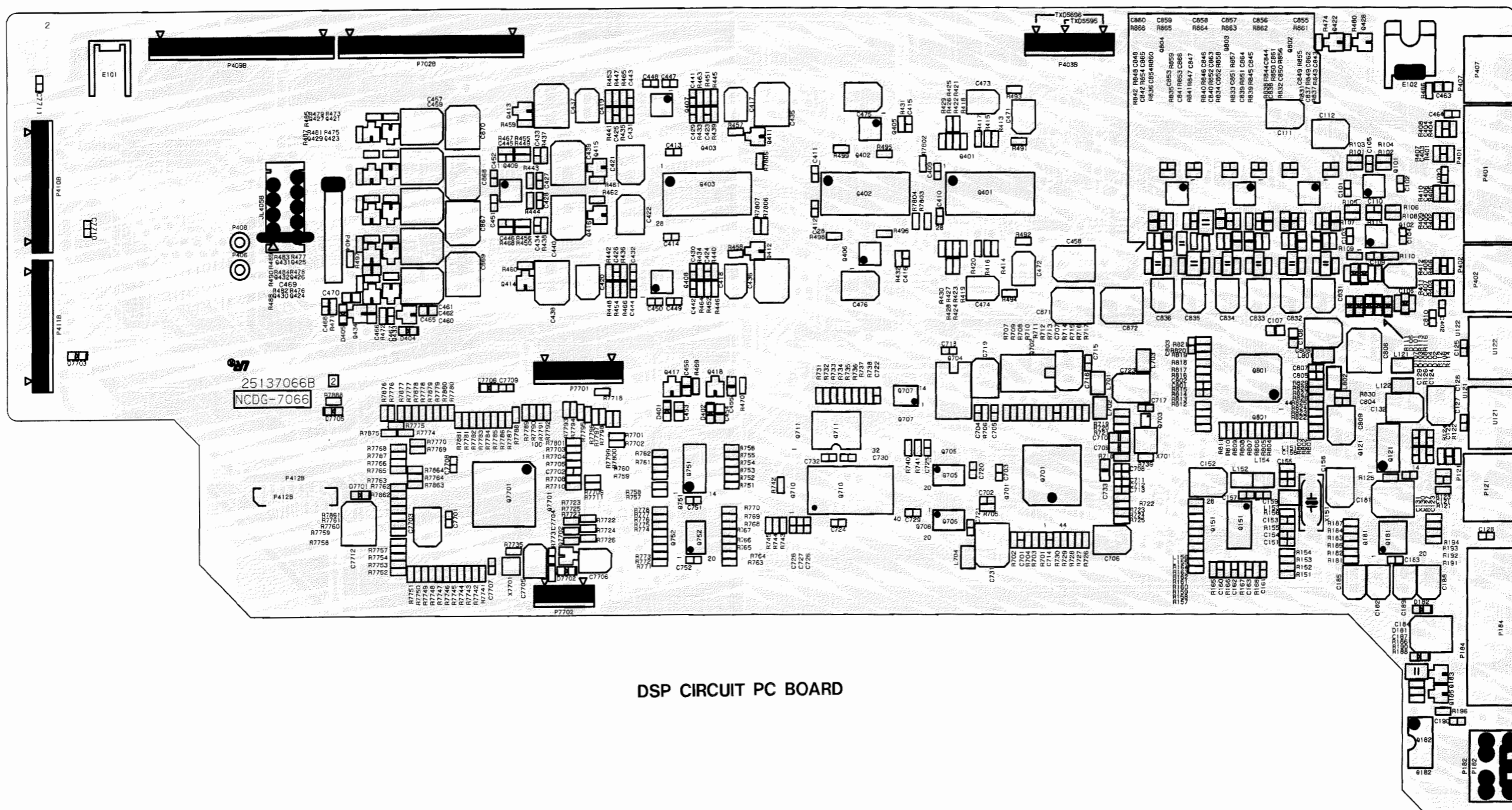

DSP CIRCUIT PC BOARD

**SCHEMATIC DIAGRAM
DSP SECTION**

A B C D E F G

1
2
3
4
5

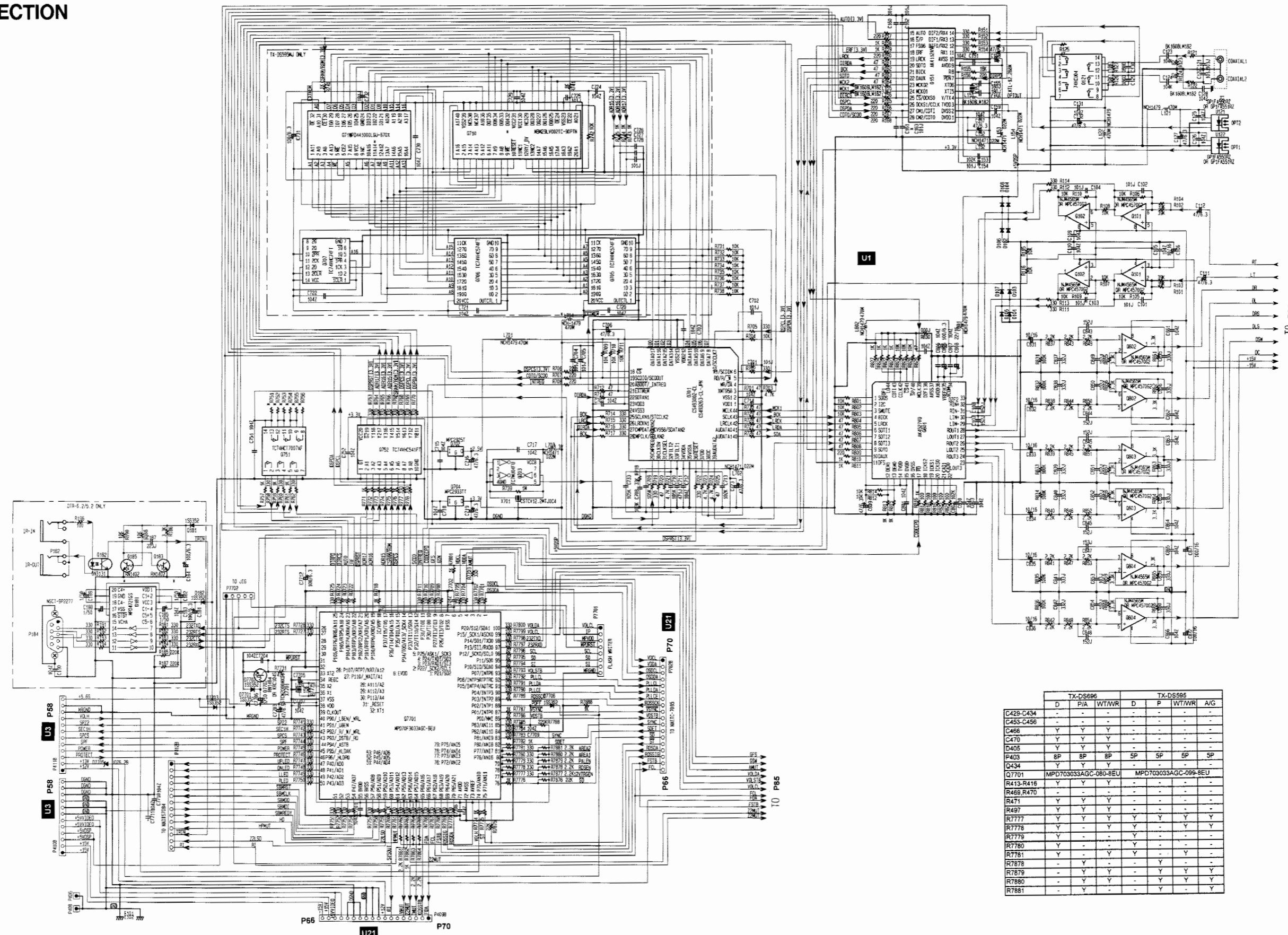

	TX-DS596				TX-DS595			
	D	P/A	WT/WR	D	P	WT/WR	A/G	
C429-C434	-	-	-	-	-	-	-	
C453-C456	-	-	-	-	-	-	-	
C466	Y	Y	Y	-	-	-	-	
C470	Y	Y	Y	-	-	-	-	
D405	Y	Y	Y	-	-	-	-	
P403	8P	8P	8P	5P	5P	5P	5P	
Q434	Y	Y	Y	-	-	-	-	
Q7701	MPD70303AGC-080-BEU			MPD70303AGC-099-BEU				
R413-R416	Y	Y	Y	-	-	-	-	
R469-R470	-	-	-	-	-	-	-	
R471	Y	Y	Y	-	-	-	-	
R497	Y	Y	Y	-	-	-	-	
R7777	Y	Y	Y	Y	Y	Y	Y	
R7776	Y	-	-	Y	-	-	-	
R7779	Y	-	-	Y	-	-	-	
R7780	Y	-	-	Y	-	-	-	
R7781	Y	-	-	Y	-	-	-	
R7878	-	Y	-	-	Y	-	-	
R7879	-	Y	-	-	Y	-	-	
R7880	-	Y	-	-	Y	-	-	
R7881	-	Y	-	-	Y	-	-	

**SCHEMATIC DIAGRAM
DSP CIRCUIT**

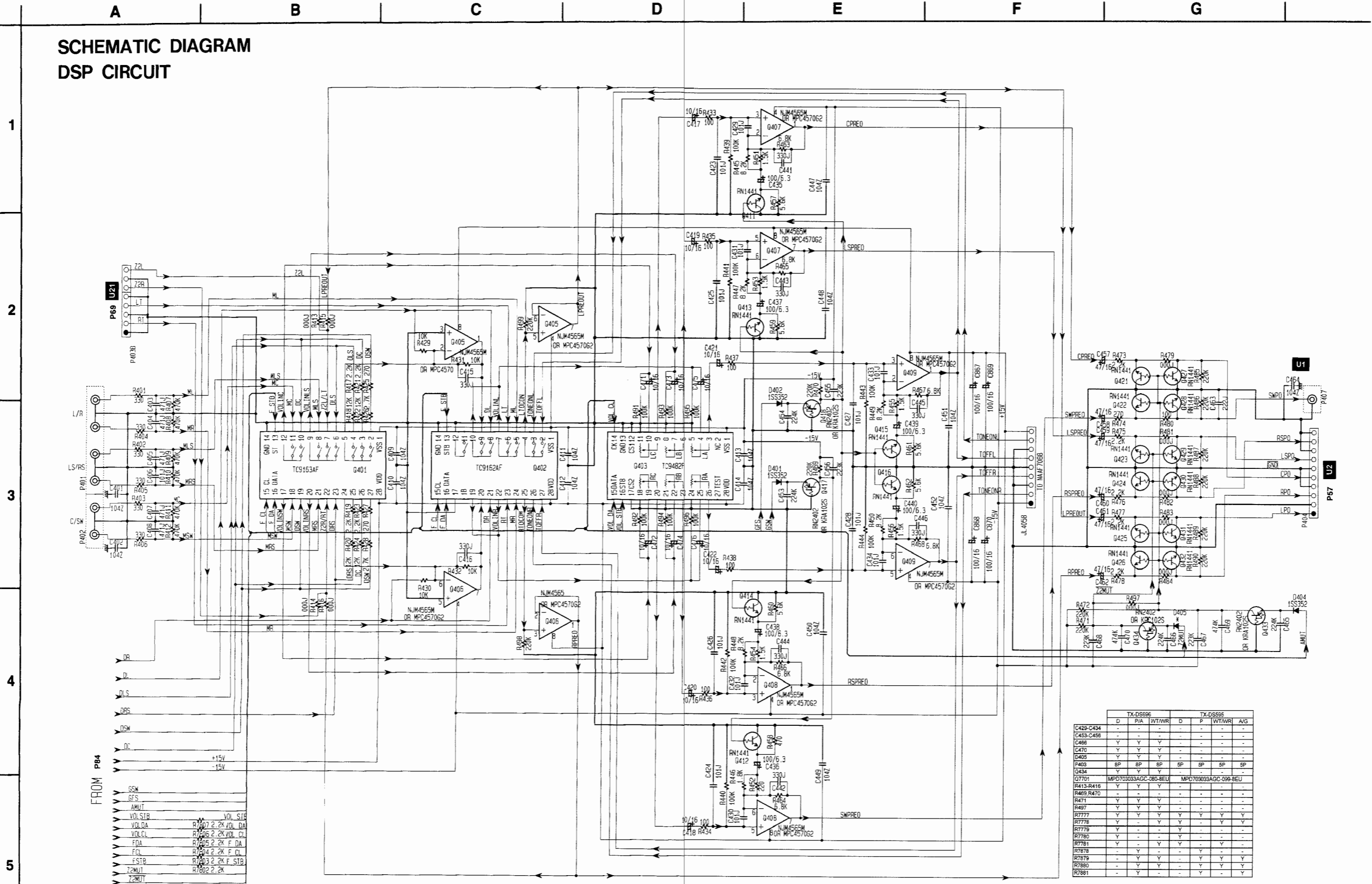

C428-C434	TX-DS596			TX-DS595		
	D	P/A	WT/WR	D	P	WT/WR
C428-C434	-	-	-	-	-	-
C435-C456	-	-	-	-	-	-
C466	Y	Y	Y	-	-	-
C470	Y	Y	Y	-	-	-
D405	Y	Y	Y	-	-	-
R403	8P	8P	8P	8P	8P	8P
G434	Y	Y	Y	-	-	-
G701	MPD703033AGC-80-BELU			MPD703033AGC-099-BELU		
R413-R416	Y	Y	Y	-	-	-
R469-R470	-	-	-	-	-	-
R471	Y	Y	Y	-	-	-
R497	Y	Y	Y	-	-	-
R777	Y	Y	Y	Y	Y	Y
R7778	Y	Y	Y	Y	Y	Y
R7779	Y	-	-	Y	-	-
R7780	Y	-	-	Y	-	-
R7781	Y	-	-	Y	-	-
R7878	-	Y	Y	-	Y	Y
R7879	-	Y	Y	-	Y	Y
R7880	-	Y	Y	-	Y	Y
R7881	-	Y	Y	-	Y	Y

ADJUSTMENTS AND CONFIRMATION PROCEDURES

Idling current adjustment

Before Idling adjustment, turn the trimming resistors R6040, R6041, R6042, R6043 and R6044 to counter clockwise.

Connect the DC voltmeter to sockets P6080, P6081, P6082, P6083 and P6804.

After turn POWER to ON, adjust the trimming resistors R6040, R6041, R6042, R6043 and R6044 so that the reading of voltmeter becomes 5.0 mV.

After adjustment, attach the top cover.

Confirm the voltage of points above after five minutes.

When less than 6.0 mV, readjust the resistors above so that the voltage becomes 6.0 mV.

When 6.0 mV to 8.0 mV, you are not necessary to adjust.

When more than 8.0 mV, readjust the resistors above so that the voltage becomes 8.0 mV.

Note: No load and No signal

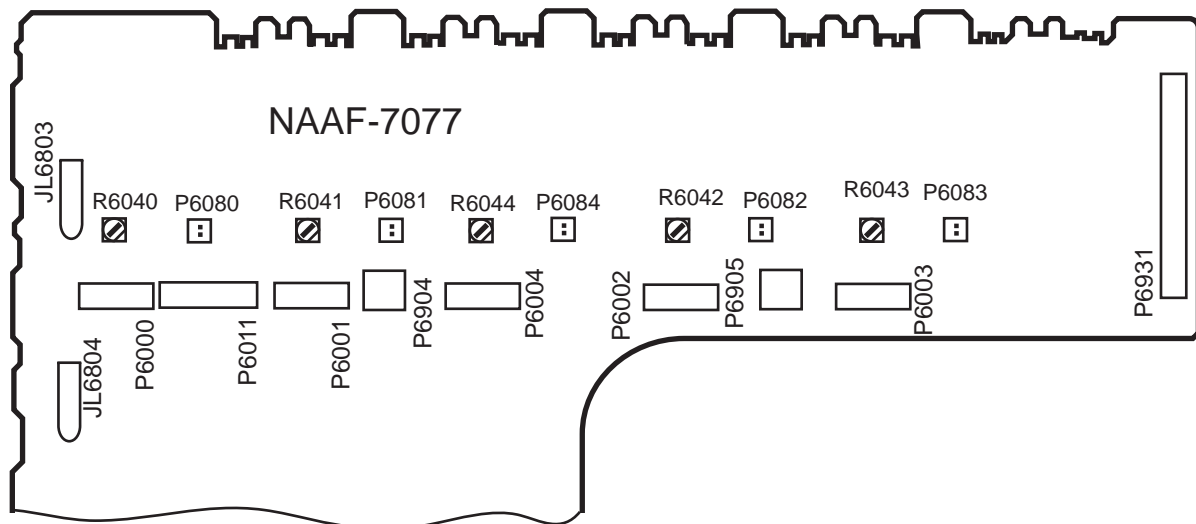

Confirmation of protection circuit

1. Confirmation of operation of speaker relay

Confirm that the speaker relay turns ON approximate. 5 seconds after the power switch is turned ON.

Confirm that the speaker relay turns OFF immediately after the power switch is turned OFF.

2. Confirmation of DC detection circuit

Connect the shored plug between the both terminals of P5601.

Press and hold down DVD button, then press STANDBY button.

During "TEST-1" on the FL tube light on, press ZONE 2 (TX-DS696) or SPEAKER A (TX-DS595) button.

Apply DC 1.5 to 3V to MULTI CHANNEL INPUT terminal with no load.

Confirm that the speaker relay turns OFF.

Apply DC -1.5 to -3V to MULTI CHANNEL INPUT terminal with no load.

Confirm that the speaker relay turns OFF.

After the adjustment, disconnect the shorted plug.

Caution: Don't apply DC voltage more than 1 sec..

3. Confirmation of Current detection circuit

Connect the shored plug between the both terminals of P5601.

Press and hold down DVD button, then press STANDBY button.

During "TEST-1" on the FL tube light on, press ZONE 2 (TX-DS696) or SPEAKER A (TX-DS595) button.

Connect the differentiating circuit and apply the 200Hz square signal to MULTI CHANNEL INPUT terminal.

Adjust the attenuator or Volume so that the output level becomes 35V p-p.

Confirm that the speaker relay does not turn OFF when a 3.0 ohm load is connected.

Confirm that the speaker relay turns OFF when a 1.5 ohm load is connected.

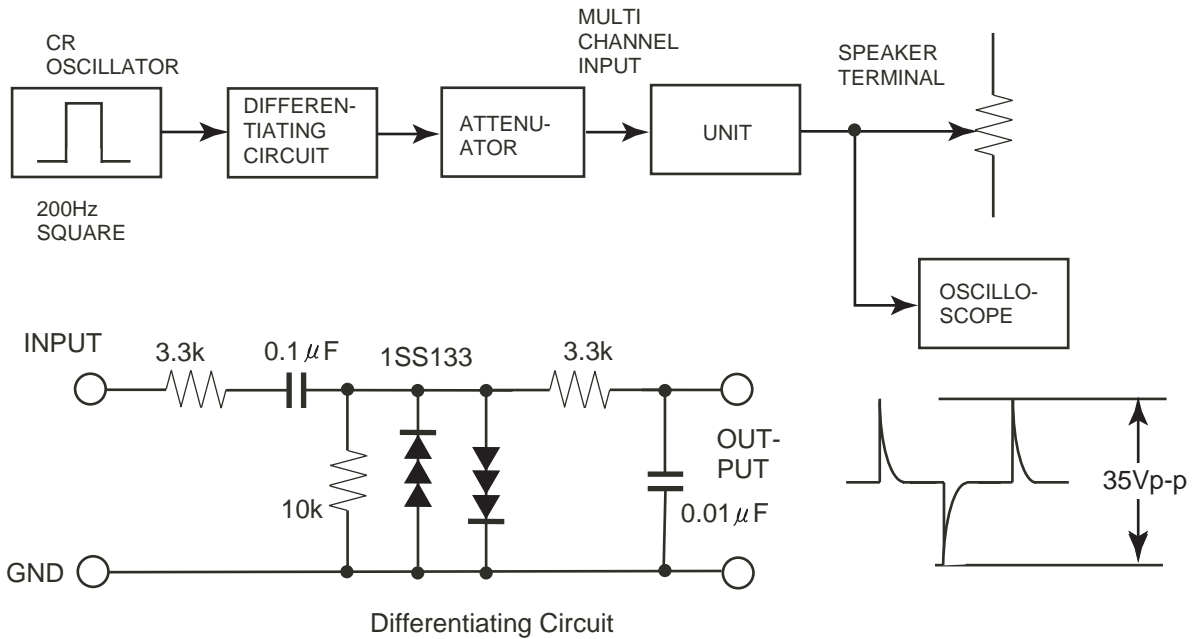

Test Mode

1. Turn POWER button on.
2. Press and hold down DVD button, then press STANDBY button.
3. During "TEST-1" on the FL tube is displayed, press CD button to set the unit to the test mode of FL tube.

Note: VIDEO 1:TEST-1 VIDEO 2 :TEST-2 ZONE2/SP A: UP
 VIDEO 3 :TEST-3 VIDEO 4:TEST-4 REC OUT/SP B: DOWN

Test mode of FL tube

TX-DS696: Press ZONE 2 or REC OUT button to change the test mode of FL tube.
 TX-DS595: Press SPEAKER A or SPEAKER B button to change the test mode of FL tube.

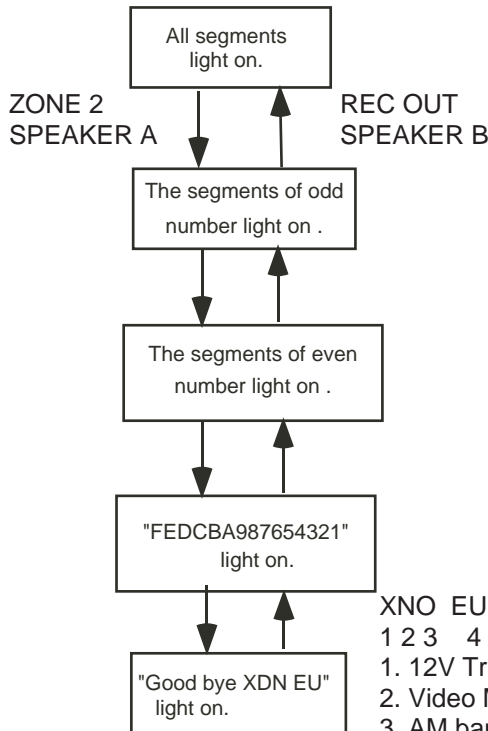
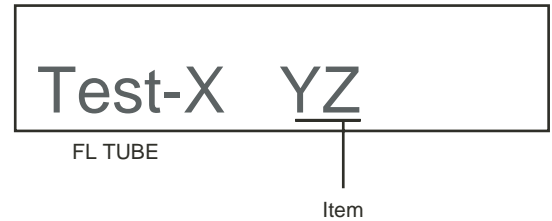

XNO EU
 1 2 3 4

1. 12V Trigger T: Use
2. Video Mode N: NTSC P: PAL AUTO
3. AM band step 9: 9 kHz step 0:10 kHz step
4. Tuner band EU:Europe US: USA SA:Saudi JP:Japan

Press POWER button to finish the test mode of FL tube.

Confirmation of voltage sensor

1. Set the unit to TEST-3-4.
2. Apply the signal 1kHz, -15dBV to the MULTI-CH input. Confirm that the FM STEREO is displayed. Confirm the all channels except SUBWOFFER.
3. When connect the resistor 1.2 kohm/1 W between the terminals COM and TH1 of P6401, confirm that the spaker relays of RL6901 and RL6902 turn off.
 Note: No input signal.
4. When change SPEAKER IMPEDANCE switch to 4 ohm, confirm that the speaker relays of RL6901 and RL6902 turn off.
 Note: No input signal.

Confirmation of thermal protect

Set the unit to TEST-1-00 with no input signal. When connect the resistor 1.2 kohm/1 W between the both terminals of P6401, confirm that all speaker relays turn off.

A B C D E

EXPLODED VIEW

1

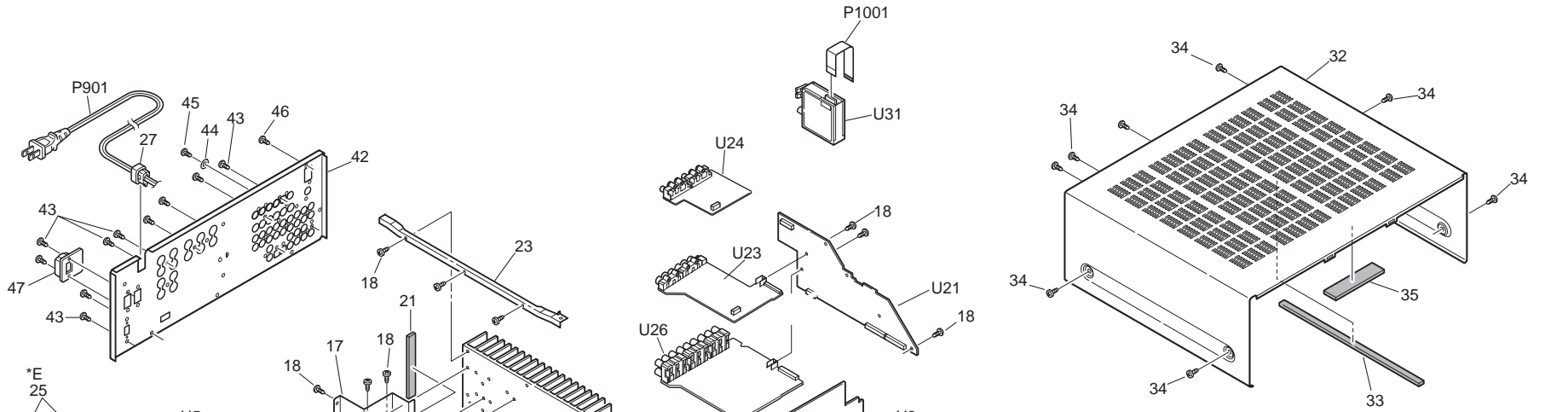

2

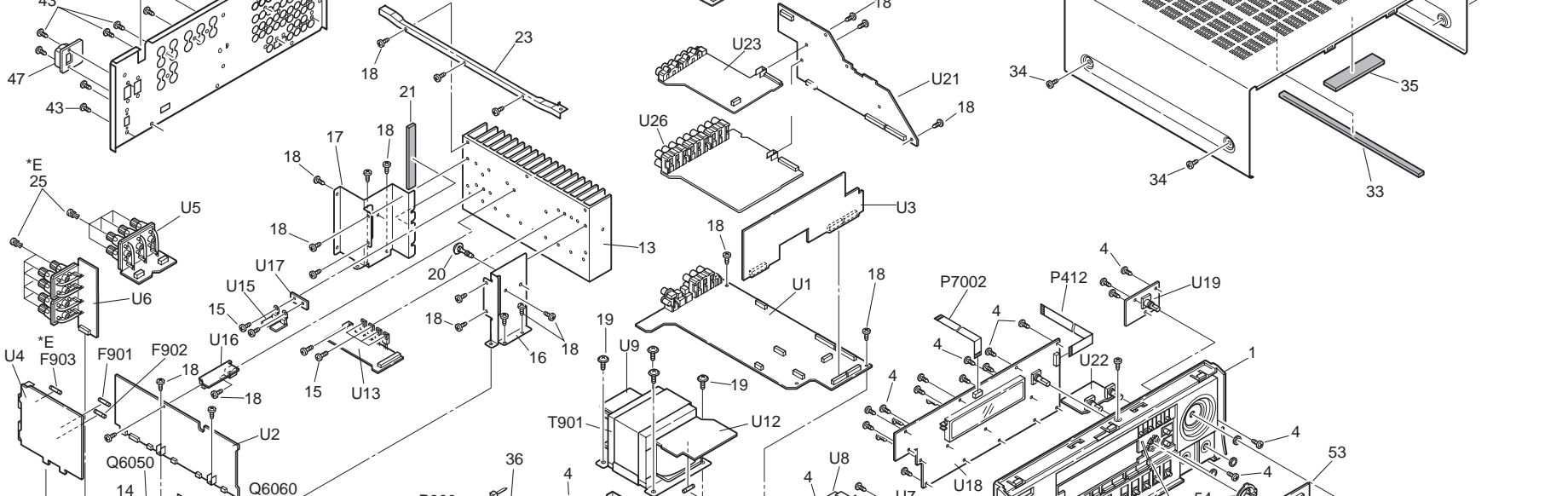

3

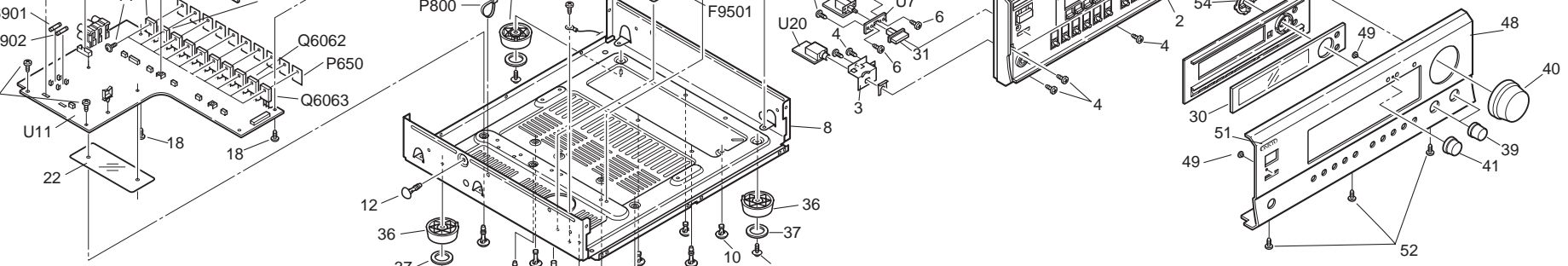

4



PARTS LIST

REF.NO.	PART NO.	DESCRIPTION	REF.NO.	PART NO.	DESCRIPTION
1	27111192	Front bracket 	52	838430088	3TTB+8B(BC), Self-tapping screw
	27111193	Front bracket <S>	53	27215345	Decorative frame <D/WT/A>
	27111194	Front bracket <G>		27215346	Decorative frame <P>
2	29110157	Tape, copper		27215347	Decorative frame <S>
3	27141756	Retainer HP		27215348	Decorative frame <G>
4	838130088	3TTB+8B,Self-tapping screw	54	28198922	Facet
6	82143010	3P+10FN(BC),Pan head screw	55	880048	P-3055B-8L, Plastic rivet <P/A/GT>
8	27100393A	Chassis	F6901,F6902	252198	⚠ 8A-UL, Fuse <D>
10	27191044	KGPS-8RF,Holder	F6901,F6902	252099	⚠ 8A-EAK, Fuse <P/WT/WR/A/GT>
11	27190503A	KGLS-8RF,Holder	F901	252166	⚠ 6.3A-UL/T237, Fuse <D/WT/WR>
12	27190511	KGLS-16RF,Holder	F902	252076 or	⚠ 3.15A-SE-EAK or
13	27160482A	Heatsink		252242	⚠ 3.15A-SE-TL250V, Fuse <P/WT/WR/A/GT>
14	801433	3SMS8W.SW+14B(BC),Special screw	F903	252075 or	⚠ 2.5A-SE-EAK or
15	838430107	3TTB+10S(BC),Self-tapping screw		252241	⚠ 2.5A-SE-TL250V,Fuse <P>
16	27141782	Retainer F	F9501	252075 or	⚠ 2.5A-SE-EAK or
17	27141783	Retainer R		252241	⚠ 2.5A-SE-TL250V,Fuse <P/WT/WR/A/GT>
18	838130088	3TTB+8B,Self-tapping screw		252160	⚠ 2.5A-UL/T-237, Fuse <D>
19	830440089	4TTC+8C(BC),Self-tapping screw	P1001	2047151012	NCFC7-151012,Flexible flat cable
20	27190266	KGLS-12RF,Holder	P206	2047271012	NCFC7-271012,Flexible flat cable
21	28141433	Cushion	P650	223024	⚠ AC238,Isolated plate
22	28175270	Isolated plate	P7001	2045142212	NCFC5-142212,Flexible flat cable
23	27130863A	Bracket B	P7002	2047091012	NCFC7-091012,Flexible flat cable
27	27300750	⚠ Bushing, cord	P800	260208	Binder
28	27190965	Holder	P901	253280VOL	⚠ AS-UC-2#18,Power supply cord <D>
29	28330135A	Cap, screw		253193HIT or	AS-CEE or
30	28191908	Clear plate 		253195MAR	⚠ AS-CEE,Power supply cord <P/GT>
	28191909	Clear plate <G/S>		253197HIT	⚠ AS-SAA, Power supply cord <A>
31	28325497A	Knob, power 		253279HIT or	⚠ AS-UC-2#18 or
	28325499A	Knob, power <G>		253233KAW	⚠ AS-CEE-2,Power supply cord <WT>
	28325547A	Knob, power <S>		253267KAW,	⚠ AS-CCEE,
32	28184802	Top cover 		253285HIT or	⚠ AS-CCEE or
	28184803	Top cover <S>		253286VOL	⚠ AS-CCEE, Power supply cord <WR>
	28184804	Top cover <G>	Q6050-Q6054	2203563,	* KTC5242-O
33	28141449	t9*280*9, Cushion		2203562,	* KTC5242-R
34	838930088	3TTB+8B(UN),Self-tapping screw <G/S>		2202843,	* 2SC5242-O
	838430088	3TTB+8B(BC), Self-tapping screw 		2202842,	* 2SC5242-R
35	28141453	t1.0*100*25,Cushion		2201653,	* 2SC3856-O
36	27175319A	Leg		2201655 or	* 2SC3856-P
37	28141332	Cushion		2201654	* 2SC3856-Y,Transistor
38	831430088	3TTW+8B(BC),Self-tapping screw	Q6060-Q6064	2203553,	* KTA1962-O
39	28325405	Knob, tone 		2203552,	* KTA1962-R
	28325407	Knob, tone <G>		2202833,	* 2SA1962-O
	28325474	Knob, tone <S>		2202832,	* 2SA1962-R
40	28325907	Knob, volume <D>		2201663,	* 2SA1492-O
	28325898	Knob,volume <P/A/WT>		2201665 or	* 2SA1492-P
	28325899	Knob, volume <S>		2201664	* 2SA1492-Y,Transistor
	28325900	Knob, volume <G>	T901	2301509	⚠ NPT-1411D,Power transformer <D>
41	28325904	Knob, DSP 		2301510	⚠ NPT-1411P,Power transformer <P/A>
	28325905	Knob, DSP <S>		2301511	⚠ NPT-1411DG,Power transformer <WT/WR/GT>
	28325906	Knob, DSP <G>	U1	1A896566-1H	NADG-7066-1H,DSP circuit PC board ass'y <D>
42	27122794	Rear panel <D>		1A896566-1I	NADG-7066-1I,DSP circuit PC board ass'y <P>
	27122795	Rear panel <P>		1A896566-1J	NADG-7066-1J,DSP circuit PC board ass'y <WT/WR>
	27122796	Rear panel <WT>		1A896566-1K	NADG-7066-1K,DSP circuit PC board ass'y <A/GT>
	27122797	Rear panel <A>	U2	1A896568-1H	NAAF-7068-1H,Power amplifier A PC board ass'y <D>
	27122798	Rear panel <WR>		1A896568-1I	NAAF-7068-1I,Power amplifier A PC board ass'y <P>
	27122799	Rear panel <GT>		1A896568-1J	NAAF-7068-1J,Power amplifier A PC board ass'y <WT>
43	838430088	3TTB+8B(BC), Self-tapping screw		1A896568-1K	NAAF-7068-1K,Power amplifier A PC board ass'y <A>
44	87643010	W3*10F(BC),Flat washer		1A896568-1L	NAAF-7068-1L,Power amplifier A PC board ass'y <WR>
45	838930088	3TTB+8B(UN),Self-tapping screw		1A896568-1M	NAAF-7068-1M,Power amplifier A PC board ass'y <GT>
46	838430068	3TTB+6B(BC),Self-tapping screw	U3	1A896569-1H	NAETC-7069-1H,Terminal PC board ass'y <D>
47	27191130	⚠ Holder,outlet <WR>		1A896569-1I	NAETC-7069-1I,Terminal PC board ass'y <P>
48	27212273	Front panel <D/WT/A>		1A896569-1J	NAETC-7069-1J,Terminal PC board ass'y <WT>
	27212274	Front panel <P>		1A896569-1K	NAETC-7069-1K,Terminal PC board ass'y <A>
	27212275	Front panel <S>		1A896569-1L	NAETC-7069-1L,Terminal PC board ass'y <WR>
	27212276	Front panel <G>		1A896569-1M	NAETC-7069-1M,Terminal PC board ass'y <GT>
49	28198778	Facet			
51	28135244	Badge 			
	28135245	Badge <G/S>			

PARTS LIST

REF.NO.	PART NO.	DESCRIPTION	
U4	1A896570-1H	NAPS-7070-1H,Primary circuit PC board ass'y <D>	
	1A896570-1I	NAPS-7070-1I,Primary circuit PC board ass'y <P>	
	1A896570-1J	NAPS-7070-1J,Primary circuit PC board ass'y <WT>	
	1A896570-1K	NAPS-7070-1K,Primary circuit PC board ass'y <A>	
	1A896570-1L	NAPS-7070-1L,Primary circuit PC board ass'y <WR>	
U5	1A896570-1M	NAPS-7070-1M,Primary circuit PC board ass'y <GT>	
	1A896571-1H	NAETC-7071-1H,Speaker terminal A PC board ass'y <D>	
	1A896571-1I	NAETC-7071-1I,Speaker terminal A PC board ass'y <P>	
	1A896571-1J	NAETC-7071-1J,Speaker terminal A PC board ass'y <WT>	
	1A896571-1K	NAETC-7071-1K,Speaker terminal A PC board ass'y <A>	
U6	1A896571-1L	NAETC-7071-1L,Speaker terminal A PC board ass'y <WR>	
	1A896571-1M	NAETC-7071-1M,Speaker terminal A PC board ass'y <GT>	
	1A896572-1H	NAETC-7072-1H,Speaker terminal B PC board ass'y <D>	
	1A896572-1I	NAETC-7072-1I,Speaker terminal B PC board ass'y <P>	
	1A896572-1J	NAETC-7072-1J,Speaker terminal B PC board ass'y <WT>	
U7	1A896572-1K	NAETC-7072-1K,Speaker terminal B PC board ass'y <A>	
	1A896572-1L	NAETC-7072-1L,Speaker terminal B PC board ass'y <WR>	
	1A896572-1M	NAETC-7072-1M,Speaker terminal B PC board ass'y <GT>	
	U7	25137073	NCETC-7073,PC board for holder
	U8	1A896574-1H	NASW-7074-1H,Power switch PC board ass'y <D>
1A896574-1I		NASW-7074-1I,Power switch PC board ass'y <P>	
1A896574-1J		NASW-7074-1J,Power switch PC board ass'y <WT>	
1A896574-1K		NASW-7074-1K,Power switch PC board ass'y <A>	
1A896574-1L		NASW-7074-1L,Power switch PC board ass'y <WR>	
U9	1A896574-1M	NASW-7074-1M,Power switch PC board ass'y <GT>	
	1A896575-1H	NAPS-7075-1H,Terminal PC board <D>	
	1A896575-1I	NAPS-7075-1I,Terminal PC board <P>	
	1A896575-1J	NAPS-7075-1J,Terminal PC board <WT>	
	1A896575-1K	NAPS-7075-1K,Terminal PC board <A>	
U10	1A896575-1L	NAPS-7075-1L,Terminal PC board <WR>	
	1A896575-1M	NAPS-7075-1M,Terminal PC board <GT>	
	1A896576-1H	NAETC-7076-1H,Ground PC board ass'y <D>	
	1A896576-1I	NAETC-7076-1I,Ground PC board ass'y <P>	
	1A896576-1J	NAETC-7076-1J,Ground PC board ass'y <WT>	
U11	1A896576-1K	NAETC-7076-1K,Ground PC board ass'y <A>	
	1A896576-1L	NAETC-7076-1L,Ground PC board ass'y <WR>	
	1A896576-1M	NAETC-7076-1M,Ground PC board ass'y <GT>	
	1A896577-1H	NAAF-7077-1H,Power amplifier B PC board ass'y <D>	
	1A896577-1I	NAAF-7077-1I,Power amplifier B PC board ass'y <P>	
U12	1A896578-1H	NAPS-7078-1H,Regulator circuit PC board ass'y <D>	
	1A896578-1I	NAPS-7078-1I,Regulator circuit PC board ass'y <P>	
U13	1A896579-1H	NAPS-7079-1H,Constant voltage PC board ass'y <D>	
	1A896579-1I	NAPS-7079-1I,Constant voltage PC board ass'y <P>	
U15	1A896581-1H	NAETC-7081-1H,Thermal Detector circuit PC board ass'y <D>	
	1A896581-1I	NAETC-7081-1I,Thermal Detector circuit PC board ass'y <P>	
U17	25137083	NCETC-7083,PC board	
U18	1A896584-1H	NADIS-7084-1H,Display circuit PC board ass'y <D>	
	1A896584-1I	NADIS-7084-1I,Display circuit PC board ass'y <P>	
	1A896584-1J	NADIS-7084-1J,Display circuit PC board ass'y <S>	
	1A896584-1K	NADIS-7084-1K,Display circuit PC board ass'y <G>	
U19	1A896585-1H	NASW-7085-1H, Volume PC board ass'y <D>	
	1A896585-1I	NASW-7085-1I, Volume PC board ass'y <P>	
	1A896585-1J	NASW-7085-1J, Volume PC board ass'y <S>	
U20	1A896585-1K	NASW-7085-1K, Volume PC board ass'y <G>	
	1A896586-1H	NAETC-7086-1H,Headphone terminal PC board ass'y <D>	
	1A896586-1I	NAETC-7086-1I,Headphone terminal PC board ass'y <P>	
U21	1A896586-1J	NAETC-7086-1J,Headphone terminal PC board ass'y <S>	
	1A896586-1K	NAETC-7086-1K,Headphone terminal PC board ass'y <G>	
	1A896587-1H	NAETC-7087-1H,Terminal PC board ass'y <D>	
U22	1A896587-1I	NAETC-7087-1I,Terminal PC board ass'y <P>	
	1A896587-1J	NAETC-7087-1J,Terminal PC board ass'y <S>	
	1A896587-1K	NAETC-7087-1K,Terminal PC board ass'y <G>	
U23	1A896588-1H	NAAF-7088-1H,Tone control circuit PC board ass'y <D>	
	1A896588-1I	NAAF-7088-1I,Tone control circuit PC board ass'y <P>	
	1A896588-1J	NAAF-7088-1J,Tone control circuit PC board ass'y <S>	
U24	1A896588-1K	NAAF-7088-1K,Tone control circuit PC board ass'y <G>	
	1A896595-1H	NAVD-7095-1H,S video terminal PC board ass'y <D>	
U25	1A896595-1I	NAVD-7095-1I,S video terminal PC board ass'y <P>	
	1A896596-1H	NAVD-7096-1H,Composite video PC board ass'y <D>	
U26	1A896596-1I	NAVD-7096-1I,Composite video PC board ass'y <P>	

REF.NO.	PART NO.	DESCRIPTION
U26	1A896597-1H	NAAF-7097-1H, Input terminal PC board ass'y<D>
	1A896597-1I	NAAF-7097-1I, Input terminal PC board ass'y<P>
U31	240138A or	ENG06501QR or
	240134	TFCE1U114A, Tuner unit <D>
	240139A or	ENG07501QR or
	240135	TFCE1E512A, Tuner unit <P>

CAUTION: Replacement for transistor of mark *, if necessary must be made from the same beta group (Hfe) as the original type.

NOTE: THE COMPONENTS IDENTIFIED BY MARK  ARE CRITICAL FOR RISK OF FIRE AND ELECTRIC SHOCK. REPLACE ONLY WITH PART NUMBER SPECIFIED.

Note:

: Black model only
 <G>: Golden model only
 <S>: Silver model only
 <D>: 120V model only
 <P>: European model only
 <WT>: Worldwide model only
 <GT>: 220-230 V model only
 <A>: Australian model only
 <WR>: Chinese model only

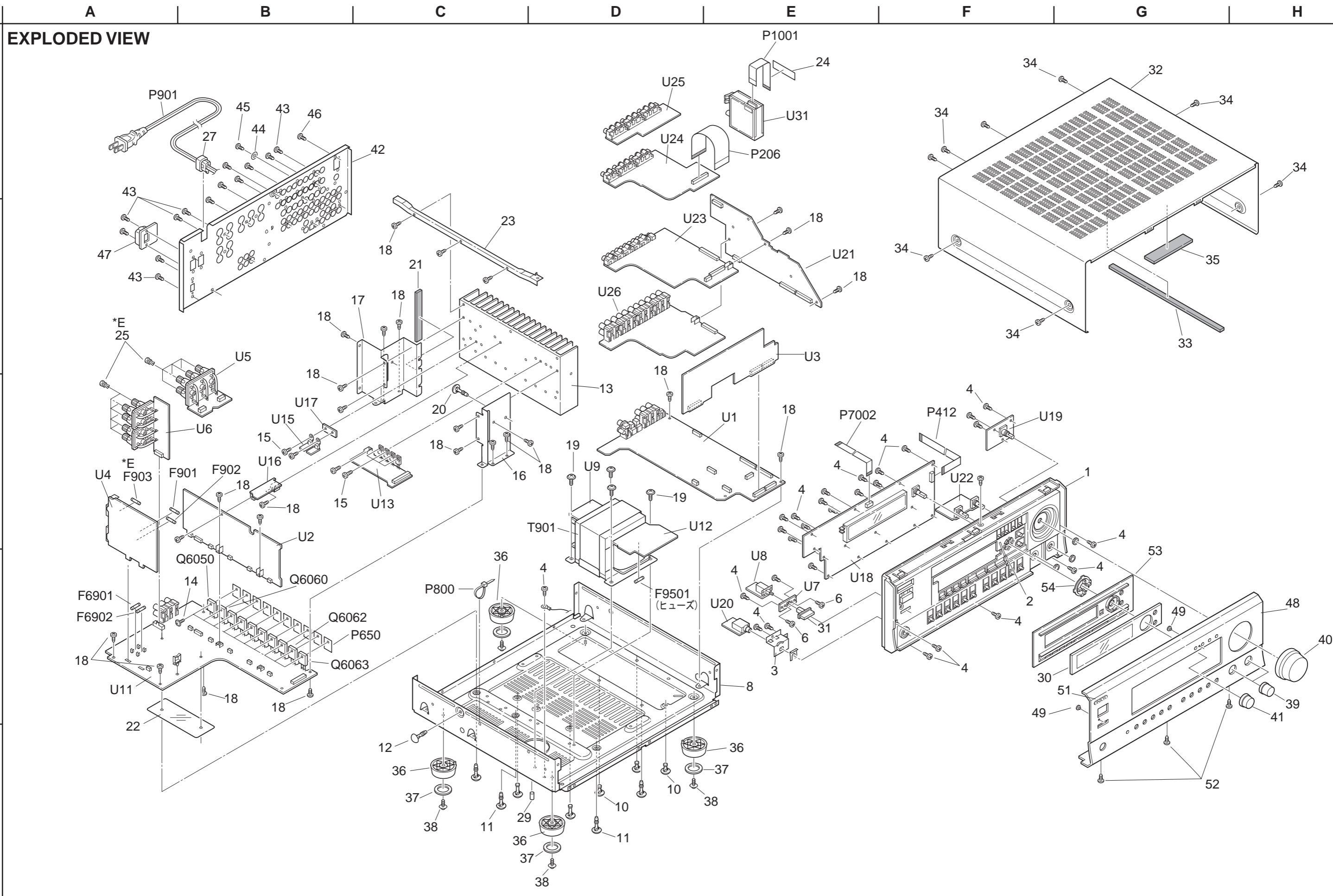

PARTS LIST

REF.NO.	PART NO.	DESCRIPTION	REF.NO.	PART NO.	DESCRIPTION
1	27111192	Front bracket 	49	28198778	Facet
	27111193	Front bracket <S>	51	28135244	Badge
	27111194	Front bracket <G>		28135245	Badge <G/S>
2	29110157	Tape, copper	52	838430088	3TTB+8B(BC), Self-tapping screw
3	27141756	Retainer HP	53	27215345	Decorative frame <D/WT/A>
4	838130088	3TTB+8B,Self-tapping screw		27215346	Decorative frame <P>
6	82143010	3P+10FN(BC),Pan head screw		27215347	Decorative frame <S>
8	27100393A	Chassis		27215348	Decorative frame <G>
10	27191044	KGPS-8RF,Holder	54	28198922	Facet
11	27190503A	KGLS-8RF,Holder	55	880048	P-3055B-8L, Plastic rivet <P/A>
12	27190511	KGLS-16RF,Holder	F6901,F6902	252199	△ 10A-UL, Fuse <D>
13	27160481A	Heatsink		252100	△ 10A-EAK, Fuse <P/WT/WR/A>
14	801433	3SMS8W.SW+14B(BC),Special screw	F901	252198	△ 8A-UL, Fuse <D/WT/WR>
15	838430107	3TTB+10S(BC),Self-tapping screw	F902	252077	△ 4A-SE-EAK, Fuse <P/WT/WR/A>
16	27141782	Retainer F	F903	252075	△ 2.5A-SE-EAK,Fuse <P/A>
17	27141783	Retainer R	F9501	252075	△ 2.5A-SE-EAK,Fuse <P/WT/WR/A>
18	838130088	3TTB+8B,Self-tapping screw		252160	△ 2.5A-UL/T-237, Fuse <D>
19	830440089	4TTC+8C(BC),Self-tapping screw	P1001	2047151012	NCFC7-151012,Flexible flat cable
20	27190266	KGLS-12RF,Holder	P206	2047271012	NCFC7-271012,Flexible flat cable
21	28141433	Cushion	P650	223025	△ AC262,Isolated plate
22	28175270	Isolated plate	P7001	2045142212	NCFC5-142212,Flexible flat cable
23	27130863A	Bracket B	P7002	2047091012	NCFC7-091012,Flexible flat cable
27	27300750	△ Bushing, cord	P800	260208	Binder
28	27190965	Holder	P901	253197HIT	△ AS-SAA, Power supply cord <A>
29	28330135A	Cap, screw		253233KAW	△ AS-CEE-2,Power supply cord <P/WT>
30	28191908	Clear plate 		253279HIT or △ AS-UC-2#18 or	
	28191909	Clear plate <G/S>		253280VOL	△ AS-UC-2#18,Power supply cord <D>
31	28325497A	Knob, power 		253267KAW, △ AS-CCEE,	
	28325499A	Knob, power <G>		253285HIT or △ AS-CCEE or	
	28325547A	Knob, power <S>		253286VOL	△ AS-CCEE, Power supply cord <WR>
32	28184802	Top cover 	Q6050-Q6054	2202823 or	* 2SC5200-O or
	28184803	Top cover <S>		2202822	* 2SC5200-R,Transistor
	28184804	Top cover <G>	Q6060-Q6064	2202813 or	* 2SA1943-O or
33	28141449	t9*280*9, Cushion		2202812	* 2SA1943-R,Transistor
34	838930088	3TTB+8B(UN),Self-tapping screw <G/S>	T901	2301505	△ NPT-1410D,Power transformer <D>
	831430088	3TTW+8B(BC),Self-tapping screw 		2301506	△ NPT-1410P,Power transformer <P/A>
35	28141453	t1.0*100*25,Cushion		2301507	△ NPT-1410DG,Power transformer <WT/WR>
36	27175319A	Leg	U1	1A896566-1A	NADG-7066-1A,DSP circuit PC board ass'y <D>
37	28141332	Cushion		1A896566-1B	NADG-7066-1B,DSP circuit PC board ass'y <P>
38	831430088	3TTW+8B(BC),Self-tapping screw		1A896566-1C	NADG-7066-1C,DSP circuit PC board ass'y <WT/WR>
39	28325405	Knob, tone 		1A896566-1D	NADG-7066-1D,DSP circuit PC board ass'y <A>
	28325407	Knob, tone <G>	U2	1A896568-1A	NAAF-7068-1A,Power amplifier A PC board ass'y <D>
	28325474	Knob, tone <S>		1A896568-1B	NAAF-7068-1B,Power amplifier A PC board ass'y <P>
40	28325898	Knob, volume 		1A896568-1C	NAAF-7068-1C,Power amplifier A PC board ass'y <WT>
	28325899	Knob, volume <S>		1A896568-1D	NAAF-7068-1D,Power amplifier A PC board ass'y <A>
	28325900	Knob, volume <G>		1A896568-1E	NAAF-7068-1E,Power amplifier A PC board ass'y <WR>
41	28325901	Knob, DSP 	U3	1A896569-1A	NAETC-7069-1A,Terminal PC board ass'y <D>
	28325902	Knob, DSP <S>		1A896569-1B	NAETC-7069-1B,Terminal PC board ass'y <P>
	28325903	Knob, DSP <G>		1A896569-1C	NAETC-7069-1C,Terminal PC board ass'y <WT>
42	27122788	Rear panel <D>		1A896569-1D	NAETC-7069-1D,Terminal PC board ass'y <A>
	27122789	Rear panel <P>		1A896569-1E	NAETC-7069-1E,Terminal PC board ass'y <WR>
	27122790	Rear panel <WT>	U4	1A896570-1A	NAPS-7070-1A,Primary circuit PC board ass'y <D>
	27122791	Rear panel <A>		1A896570-1B	NAPS-7070-1B,Primary circuit PC board ass'y <P>
	27122792	Rear panel <WR>		1A896570-1C	NAPS-7070-1C,Primary circuit PC board ass'y <WT>
43	838430088	3TTB+8B(BC), Self-tapping screw		1A896570-1D	NAPS-7070-1D,Primary circuit PC board ass'y <A>
44	87643010	W3*10F(BC),Flat washer		1A896570-1E	NAPS-7070-1E,Primary circuit PC board ass'y <WR>
45	838930088	3TTB+8B(UN),Self-tapping screw	U5	1A896571-1A	NAETC-7071-1A,Speaker terminal A PC board ass'y <D>
46	838430068	3TTB+6B(BC),Self-tapping screw		1A896571-1B	NAETC-7071-1B,Speaker terminal A PC board ass'y <P>
47	27191130	△ Holder,outlet <WR>		1A896571-1C	NAETC-7071-1C,Speaker terminal A PC board ass'y <WT>
48	27212269	Front panel <D/WT/A>		1A896571-1D	NAETC-7071-1D,Speaker terminal A PC board ass'y <A>
	27212270	Front panel <P>		1A896571-1E	NAETC-7071-1E,Speaker terminal A PC board ass'y <WR>
	27212271	Front panel <S>			
	27212272	Front panel <G>			

PARTS LIST

REF.NO.	PART NO.	DESCRIPTION
U6	1A896572-1A	NAETC-7072-1A, Speaker terminal B PC board ass'y <D>
	1A896572-1B	NAETC-7072-1B, Speaker terminal B PC board ass'y <P>
	1A896572-1C	NAETC-7072-1C, Speaker terminal B PC board ass'y <WT>
	1A896572-1D	NAETC-7072-1D, Speaker terminal B PC board ass'y <A>
	1A896572-1E	NAETC-7072-1E, Speaker terminal B PC board ass'y <WR>
U7	25137073	NCETC-7073, PC board for holder
U8	1A896574-1A	NASW-7074-1A, Power switch PC board ass'y <D>
	1A896574-1B	NASW-7074-1B, Power switch PC board ass'y <P>
	1A896574-1C	NASW-7074-1C, Power switch PC board ass'y <WT>
	1A896574-1D	NASW-7074-1D, Power switch PC board ass'y <A>
	1A896574-1E	NASW-7074-1E, Power switch PC board ass'y <WR>
U9	1A896575-1A	NAPS-7075-1A, Terminal PC board <D>
	1A896575-1B	NAPS-7075-1B, Terminal PC board <P>
	1A896575-1C	NAPS-7075-1C, Terminal PC board <WT>
	1A896575-1D	NAPS-7075-1D, Terminal PC board <A>
	1A896575-1E	NAPS-7075-1E, Terminal PC board <WR>
U10	1A896576-1A	NAETC-7076-1A, Ground PC board ass'y <D>
	1A896576-1B	NAETC-7076-1B, Ground PC board ass'y <P>
	1A896576-1C	NAETC-7076-1C, Ground PC board ass'y <WT>
	1A896576-1D	NAETC-7076-1D, Ground PC board ass'y <A>
	1A896576-1E	NAETC-7076-1E, Ground PC board ass'y <WR>
U11	1A896577-1A	NAAF-7077-1A, Power amplifier B PC board ass'y <D>
	1A896577-1B	NAAF-7077-1B, Power amplifier B PC board ass'y <P/WT/WR/A>
U12	1A896578-1A	NAPS-7078-1A, Regulator circuit PC board ass'y <D>
	1A896578-1B	NAPS-7078-1B, Regulator circuit PC board ass'y <P/WT/WR/A>
U13	1A896579-1A	NAPS-7079-1A, Constant voltage PC board ass'y <D>
	1A896579-1B	NAPS-7079-1B, Constant voltage PC board ass'y <P/WT/WR/A>
U15	1A896581-1A	NAETC-7081-1A, Thermal Detector circuit PC board ass'y <D>
	1A896581-1B	NAETC-7081-1B, Thermal Detector circuit PC board ass'y <P/WT/WR/A>
U17	25137083	NCETC-7083, PC board
U18	1A896584-1A	NADIS-7084-1A, Display circuit PC board ass'y <D/WT/A>
	1A896584-1B	NADIS-7084-1B, Display circuit PC board ass'y <P>
	1A896584-1C	NADIS-7084-1C, Display circuit PC board ass'y <S>
	1A896584-1D	NADIS-7084-1D, Display circuit PC board ass'y <G>
U19	1A896585-1A	NASW-7085-1A, Volume PC board ass'y <D/WT/A>
	1A896585-1B	NASW-7085-1B, Volume PC board ass'y <P>
	1A896585-1C	NASW-7085-1C, Volume PC board ass'y <S>
	1A896585-1D	NASW-7085-1D, Volume PC board ass'y <G>
U20	1A896586-1A	NAETC-7086-1A, Headphone terminal PC board ass'y <D/WT/A>
	1A896586-1B	NAETC-7086-1B, Headphone terminal PC board ass'y <P>
	1A896586-1C	NAETC-7086-1C, Headphone terminal PC board ass'y <S>
	1A896586-1D	NAETC-7086-1D, Headphone terminal PC board ass'y <G>
U21	1A896587-1A	NAETC-7087-1A, Terminal PC board ass'y <D/WT/A>
	1A896587-1B	NAETC-7087-1B, Terminal PC board ass'y <P>
	1A896587-1C	NAETC-7087-1C, Terminal PC board ass'y <S>
	1A896587-1D	NAETC-7087-1D, Terminal PC board ass'y <G>
U22	1A896588-1A	NAAF-7088-1A, Tone control circuit PC board ass'y <D/WT/A>
	1A896588-1B	NAAF-7088-1B, Tone control circuit PC board ass'y <P>
	1A896588-1C	NAAF-7088-1C, Tone control circuit PC board ass'y <S>
	1A896588-1D	NAAF-7088-1D, Tone control circuit PC board ass'y <G>
U23	1A896590-1A	NAVD-7090-1B, S video terminal PC board ass'y <D>
	1A896590-1B	NAVD-7090-1B, S video terminal PC board ass'y <P/WT/WR/A>
U24	1A896591-1A	NAVD-7091-1A, Composite video PC board ass'y <D>
	1A896591-1B	NAVD-7091-1B, Composite video PC board ass'y <P/WT/WR/A>
U25	1A896592-1A	NAVD-7092-1A, Component video terminal PC board ass'y <D>
	1A896592-1B	NAVD-7092-1B, Component video terminal PC board ass'y <P/WT/WR/A>
U26	1A896593-1A	NAAF-7093-1A, Input terminal PC board ass'y <D>
	1A896593-1B	NAAF-7093-1B, Input terminal PC board ass'y <P/WT/WR/A>
U31	240138A or	ENG06501QR or
	240134	TFCE1U114A, Tuner unit <D>
	240139A or	ENG07501QR or
	240135	TFCE1E512A, Tuner unit <P/A/WT/WR>

CAUTION: Replacement for transistor of mark *, if necessary must be made from the same beta group (HFE) as the original type.

NOTE: THE COMPONENTS IDENTIFIED BY MARK  ARE CRITICAL FOR RISK OF FIRE AND ELECTRIC SHOCK. REPLACE ONLY WITH PART NUMBER SPECIFIED.

Note:

: Black model only
 <G>: Golden model only
 <S>: Silver model only
 <D>: 120V model only
 <P>: European model only
 <WT>: Worldwide model only
 <GT>: 220-230 V model only
 <A>: Australian model only
 <WR>: Chinese model only

PACKING VIEW

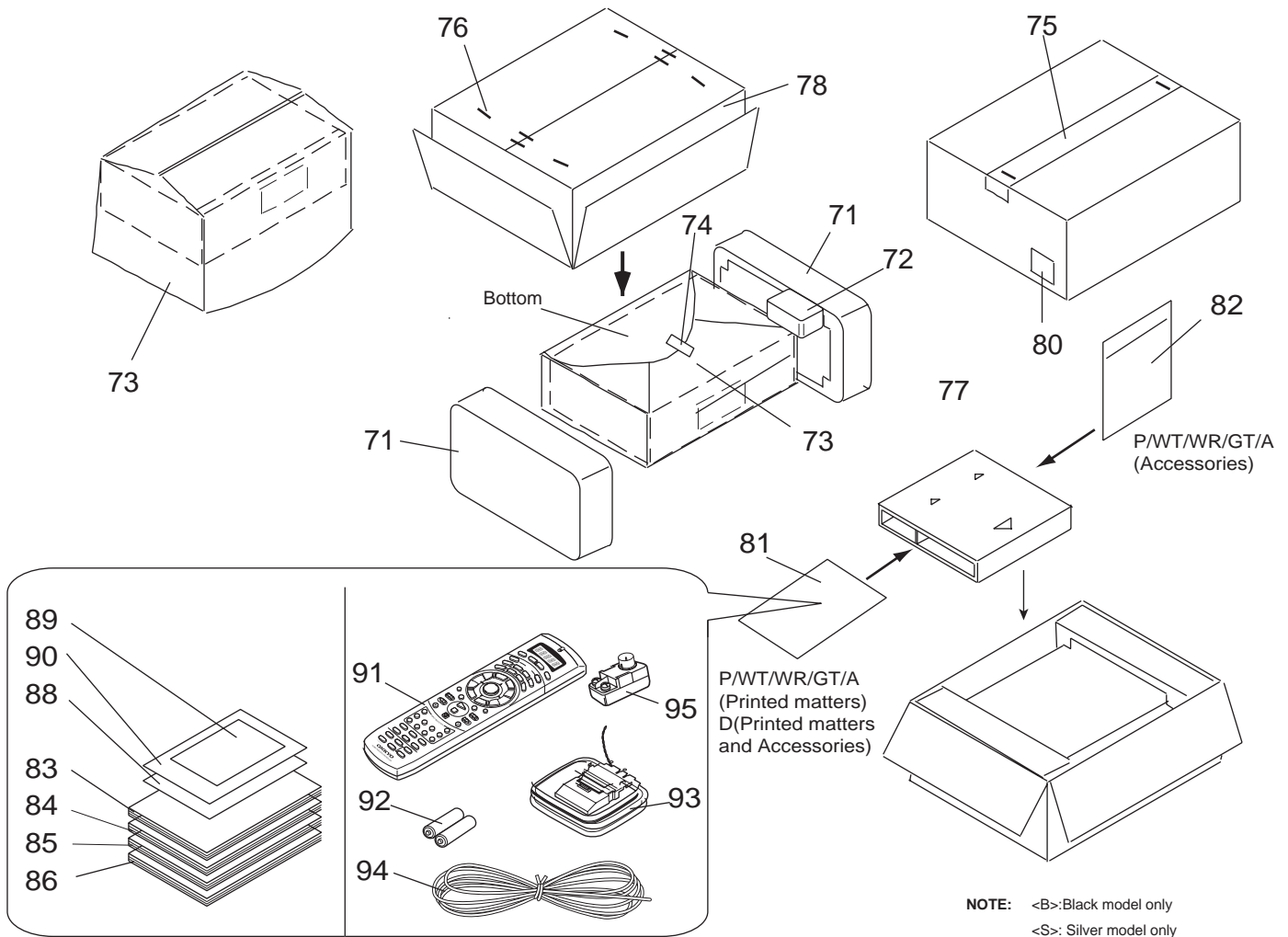

NOTE: :Black model only
 <S>: Silver model only
 <G>: Golden model only
 <D>: 120 V model only
 <P>: European model only
 <WT>: Worldwide model only
 <A>: Australian model only
 <WR>: Chinese model only
 <GT>: 220-230V model only

PARTS LIST

REF.NO.	PART NO.	DESCRIPTION	REF.NO.	PART NO.	DESCRIPTION
71	29091969	Pad	81	29100097-1A	350*250,Poly bag
72	29091981	Pad PT	82	29100097-1A	350*250,Poly bag <P/WT/WR/GT/A>
73	29100153	1020x720,Polybag	83	29343023	Instruction manual E
74	261504	Paper tape	84	29343024	Instruction manual FSI <P>
75	29110098	PP tape	85	29343025	Instruction manual GDSW <P>
76	282301	Staple	86	29343026	Instruction manual TC <WT/GT/WR>
77	29053723	Carton box S	88	29343029	Instruction sheet <D>
78	29053686A	Carton box <WT/A>	89	29365083A	Warranty card <D>
	29053687A	Carton box <P>	90	29095866	Sheet <D>
	29053688A	Carton box <S>	91	24140447	RC-447M,Remote controller
	29053689A	Carton box <G>	92	3010054	UM-3, Two batteries
	29053712A	Carton box <D>	93	232140	NMA-3057,AM loop antenna
80	29362786	Label EAN <P/WT/A>	94	292115	FM antenna <P/WT/WR/A/GT>
	29362787	Label EAN <S>		292142	FM antenna <D>
	29362788	Label EAN <G>	95	25065462	Adapter for FM antenna <WT/WR/A/GT>
	29362789	Label UPC <D>			

PACKING VIEW

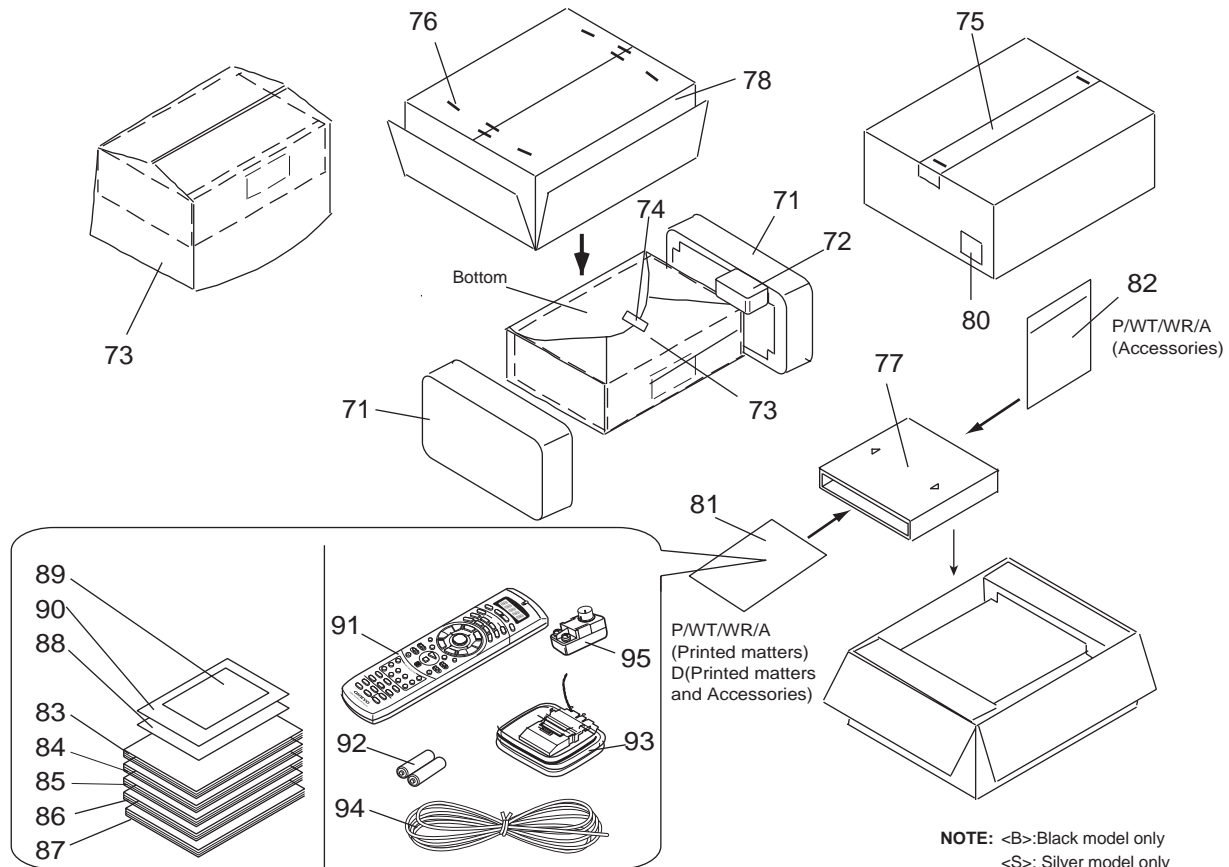

PARTS LIST

REF. NO.	PART NO.	DESCRIPTION	REF. NO.	PART NO.	DESCRIPTION
71	29091969	Pad	81	29100097-1A	350*250, Poly bag
72	29091981	Pad PT	82	29100097-1A	350*250, Poly bag <P/WT/WR/A>
73	29100153	1020x720, Polybag	83	29343015	Instruction manual E
74	261504	Paper tape	84	29343016	Instruction manual FSI <P>
75	29110098	PP tape	85	29343017	Instruction manual GDSW <P>
76	282301	Staple	86	29343018	Instruction manual T <WT>
77	29053723	Carton box S	87	29343019	Instruction manual C <WR>
78	29053682A	Carton box <WT/A>	88	29343020	Instruction sheet <D>
	29053683A	Carton box <P>	89	29365083A	Warranty card <D>
	29053684A	Carton box <S>	90	29095866	Sheet <D>
	29053685A	Carton box <G>	91	24140440	RC-440M, Remote controller
	29053711A	Carton box <D>	92	3010054	UM-3, Two batteries
79	29362772	Label	93	232140	NMA-3057, AM loop antenna
80	29362781	Label EAN <P/WT/A>	94	292115	FM antenna <P/WT/WR/A>
	29362782	Label EAN <S>		292142	FM antenna <D>
	29362783	Label EAN <G>	95	25065462	Adapter for FM antenna <WT/WR/A>
	29362784	Label UPC <D>			

NOTE: : Black model only
 <S>: Silver model only
 <G>: Golden model only
 <D>: 120 V model only
 <P>: European model only
 <WT>: Worldwide model only
 <A>: Australian model only
 <WR>: Chinese model only

ONKYO CORPORATION

Sales & Product Planning Div. : 2-1, Nisshin-cho, Neyagawa-shi, OSAKA 572-8540, JAPAN
 Tel: 072-831-8111 Fax: 072-833-5222

ONKYO U.S.A. CORPORATION

18 Park Way, Upper Saddle River, NJ 07458, U.S.A.
 Tel: 201-785-2600 Fax: 201-758-2650 E-mail: onkyo@onkyousa.com

ONKYO EUROPE ELECTRONICS GmbH

Industriestrasse 20, 82110 Germering, GERMANY
 Tel: 089-849-320 Fax: 089-849-3265 E-mail: info@onkyo.de

ONKYO CHINA LIMITED

Units 2102-2107, Metroplaza Tower I, 223 Hing Fong Road, Kwai Chung,
 N.T., HONG KONG Tel: 852-2429-3118 Fax: 852-2428-9039

